

MK Diamond Products, Inc.

www.mkdiamond.com

MK-SCARIFIER OWNER'S MANUAL & OPERATING INSTRUCTIONS

SG-9

SG-5



SG-5



SG-9

Revision 108	02.2017
Manual Part# 158537	

Caution: Read all safety and operating instructions before using this equipment. This owner's manual **MUST** accompany the equipment at all times.



MK Diamond Products, Inc.

INTRODUCTION

Congratulations on your purchase of a MK-Scarifier. We are certain that you will be pleased with your purchase. MK Diamond takes pride in producing the finest construction power tools and diamond blades in the industry.

Operated correctly, your MK-Scarifier should provide you with years of service. In order to help you, we have included this manual. This owners manual contains information necessary to operate and maintain your MK-Scarifier safely and correctly. Please take the time to familiarize yourself with the MK-Scarifier by reading and reviewing this manual.

Read and follow all safety, operating and maintenance instructions.

If you should have questions concerning your MK-Scarifier please feel free to call our friendly customer service department at (800) 421-5830.

Regards,

MK Diamond

NOTE THIS INFORMATION FOR FUTURE USE:

MODEL NUMBER:	
SERIAL NUMBER:	
PURCHASE PLACE:	
PURCHASE DATE:	

NOTE: For your (1) one year warranty to be effective, complete the warranty card (including the Serial Number) and mail it in as soon as possible.

TABLE OF CONTENTS

SAFETY	PAGE
Safety Messages	4
Damage Prevention Message	4
General Safety Precautions	4-7
California Proposition 65 Message	8
Electrical Requirements and Grounding Instructions	9
Electric Motor Safety	10-11
Safety Label Locations	12
Specific Warnings	13
Product Specifications	13
UNPACKING ASSEMBLY	
Unpacking	14
Contents	14
Transport	14
Handlebar	15
SCARIFIER DRUM	
Scarifier Drum Cutter	16
Drum Configuration	17-18
Assembly	19-20
ASSEMBLY	
Assembly	21-24
SETUP	
Vacuum Setup	25
Filling Oil Reservoir & Fuel Tank	25-26
Pre-start Inspection	26
Start-Up	27
Operation	28
Cleanup	29
MAINTENANCE	
Maintenance	30-45
THEORY	
Theory of Scarifying	46
ACCESSORIES	
Accessories	47
ORDERING & RETURN INSTRUCTIONS	
Ordering Information	48
Return Material Policy	48
CONTACT & LIMITED WARRANTY	
Contact	49
Limited Warranty	49

Read and follow all safety, operating and maintenance instructions. Failure to read and follow these instructions could result in injury or death to you or others. Failure to read and follow these instructions could also result in damage and/or reduced equipment life. Safety warnings and guidelines do not by themselves eliminate danger. They are not substitutes for proper accident prevention procedures and good judgement.

SAFETY MESSAGES

A safety message alerts you to potential hazards that could hurt you or others. Each safety message is preceded by a safety alert symbol () and one of three words: **DANGER**, **WARNING**, or **CAUTION**.



DANGER You **WILL** be **KILLED** or **SERIOUSLY INJURED** if you **DO NOT** follow directions.



WARNING You **CAN** be **KILLED** or **SERIOUSLY INJURED** if you **DO NOT** follow directions.



CAUTION You **CAN** be **INJURED** if you **DO NOT** follow directions. It may also be used to alert against unsafe practices.

DAMAGE PREVENTION AND INFORMATION MESSAGES

A Damage Prevention Message is to inform the user of important information and/or instructions that could lead to equipment or other property damage if not followed. Information Messages convey information that pertains to the equipment being used. Each message will be preceded by the word **NOTE**, as in the example below.

NOTE: Equipment and/or property damage may result if these instructions are not followed.

GENERAL SAFETY PRECAUTIONS AND HAZARD SYMBOLS

In order to prevent injury, the following safety precautions and symbols should be followed at all times!

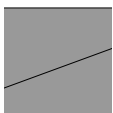

ALWAYS read this Owner's Manual before operating the machine. **DO NOT** operate or service this equipment before reading this entire manual. Read and understand all warnings, instructions and controls on the machine. Know how to stop the equipment quickly in case of emergency. It is the operators responsibility to use this machine under safe working conditions and conform with federal, state and local codes or regulations pertaining to safety, air, pollution, noise etc...



ALWAYS keep the Blade and Belt Guards in place. **DO NOT** operate this machine with any guard or safety device removed. A Guard, or any damaged part should be repaired or replaced immediately.



NEVER operate this equipment without proper protective clothing, shatterproof glasses, steel-toed boots and other protective devices required by the job. Non-slip foot wear is recommended.



PERSONAL PROTECTIVE EQUIPMENT

ALWAYS wear approved respiratory, head, ear and eye protection when operating this machine.

ACCIDENTAL STARTS!

Before starting the engine/motor, be sure the **ON/OFF** switch is in the **OFF** position to prevent accidental starting. Place the **ON/OFF** switch in the **OFF** position before performing any service operation. **ALWAYS** place the power **ON/OFF** switch in the **OFF** position when the machine is not in use.



ROTATING PARTS

Keep hands, feet, hair, and clothing away from all moving parts to prevent injury. Never operate the motor with covers, shrouds, or guards, removed.



HOT PARTS!

Engine components can become extremely hot from operation. To prevent severe burns, do not touch these areas while the engine is running, or immediately after it is turned off. Never operate the engine with heat shields removed.



OVER SPEED

NEVER tamper with the governor components or settings to increase the maximum speed. Severe personal injury and damage to the engine or equipment can result if operated at speeds above maximum.



ELECTRICAL SHOCK

NEVER touch electrical wires or components while the engine is running. Exposed, frayed or worn electrical wiring and plugs can be sources of electrical shock which could cause severe injury or burns. Do not touch the plug with wet hands.



ALWAYS avoid inhalation of and skin contact with silica dust and/or mist. Provide proper dust removal. Use dust-collection system when applicable.



NEVER operate the machine in an explosive atmosphere or near combustible materials. Sparks from the cutting-action of this machine can ignite flammable materials, liquids, gases or dust.



This equipment should not be operated by persons under 18 years of age.



KEEP CHILDREN AWAY

All visitors and children should be kept a safe distance from work area. Maintain a safe operating distance to other personnel.



MAKE THE WORKSHOP KID PROOF

Make the workshops kid proof by using padlocks, master switches or by removing starter keys.



DO NOT FORCE THE TOOL

A power tool will do a job better and safer operating at the rate for which it was designed. **DO NOT** force a tool or an attachment to do a job that it was not designed to do.

**USE PROPER APPAREL**

DO NOT wear loose clothing, gloves, neckties, rings, bracelets, or other jewelry that may be caught in moving parts. Non-slip footwear is recommended. Wear protective hair covering to contain long hair.

**SECURE WORK**

Clamps or a vise should be used to hold work whenever practical. Keeping your hands free to operate a power tool is safer.

**DO NOT OVERREACH**

Keep proper footing and balance at all times by not overreaching.

**DISCONNECT TOOLS**

Power tools should always be disconnected before servicing, adjusting or when changing accessories, such as blades, bits, cutters, and the like.

**MAINTAIN TOOLS WITH CARE**

Keep tools clean and maintained for the best and safest performance. Always follow maintenance instructions and examine the machine before use. If any abnormal vibrations or noises occurs, turn off machine immediately and have the problem corrected before further use.

**REMOVE ADJUSTING KEYS AND WRENCHES**

Form a habit of checking to see that keys and adjusting wrenches are removed from the power tool before it is turned on.

**KEEP WORK AREA CLEAN**

Cluttered work areas and benches invite accidents. Keep area around machine clear of obstructions which could cause persons to fall.

**DO NOT USE IN DANGEROUS PLACES**

DO NOT operate equipment in dangerous or hazardous environments. **DO NOT** use power tools in damp or wet locations nor expose them to rain. Always keep the work area well lighted.

**USE RECOMMENDED ACCESSORIES**

Consult the owner's manual for recommended accessories. Using improper accessories may increase the risk of personal or by-stander injury. Unauthorized equipment modifications will void all warranties. Manufacturer does not assume responsibility for any accident due to equipment modifications.



ALWAYS ensure that the machine is on level ground before using.

**NEVER STAND ON THE TOOL**

Serious injury could occur if a power tool is tipped, or if a cutting tool is unintentionally contacted.

**TRANSPORT**

When loading or unloading the machine, use caution. Remove the blade prior to hoisting, loading and transporting the machine.

**CHECK FOR DAMAGED PARTS**

Before using a power tool, check for damaged parts. A guard or any other part that is damaged should be carefully checked to determine if it would operate properly and perform its intended function. Always check moving parts for proper alignment or binding. Check for broken parts and mountings and all other conditions that may affect the operation of the power tool. A guard, or any damaged part, should be properly repaired or replaced. Always check the machine for loose bolts before starting.

**DIRECTION OF ROTATION**

A blade or cutter should always be installed so that rotation is in the direction of the arrow imprinted on the side of the blade or cutter. It should correspond with the rotational direction of the motor. Always feed work into a blade against the direction of rotation.

**NEVER LEAVE A TOOL UNATTENDED**

TURN POWER OFF - Do not leave a tool until it comes to a complete stop. **ALWAYS** turn a power tool **OFF** when leaving the work area, or, when a cut is finished.



NEVER disconnect any "emergency or safety devices". These devices are intended for operator safety. Disconnection of these devices can cause severe injury, bodily harm, or even death! Disconnection of any of these devices will void all warranties. Unauthorized equipment modifications will void all warranties. Manufacturer does not assume responsibility for any accident due to equipment modifications.



NEVER use this machine with any cutter designed for woodworking.



NEVER operate this equipment when not feeling well due to fatigue, illness or taking medicine.



NEVER operate this equipment under the influence of drugs or alcohol.



On belt driven equipment, overtensioning of belts will result in premature crank and/or bearing failure.



Whenever necessary, replace nameplate, operation and safety decals when they become difficult to read.



ALWAYS store equipment properly when it is not being used. Equipment should be stored in a clean, dry location out of the reach of children



DO NOT lend or rent this equipment without including the Owner's Manual and the Engine/Motor Manufacturer's Manual.



Check the chemical properties of the material to be cut/grinded and follow all EPA/OSHA Regulations. (cut/ground)

SILICA DUST WARNING

Grinding/cutting/drilling of masonry, concrete, metal and other materials with silica in their composition may give off dust or mists containing crystalline silica. Silica is a basic component of sand, quartz, brick clay, granite and numerous other minerals and rocks. Repeated and/or substantial inhalation of airborne crystalline silica can cause serious or fatal respiratory diseases, including silicosis. In addition, California and some other authorities have listed respirable crystalline silica as a substance known to cause cancer. When cutting such materials, always follow respiratory precautions.

Use appropriate NIOSH-approved respiratory protection where dust hazard may occur. Paper masks or surgical masks without a NIOSH approval number are not recommended because they do little to protect the worker. For more information about respirator programs, including what respirators have received NIOSH approval as safe and effective, please visit the NIOSH website at:
<http://www.cdc.gov/niosh/topics/respirators>

Observe OSHA regulations for respirator use (29 C.F.R. §1910.134).
Visit <http://www.osha.gov> for more information.

CALIFORNIA PROPOSITION 65 MESSAGE

Some dust created by power sanding, sawing, grinding, drilling, and other construction activities contain chemicals known (to the State of California) to cause cancer, birth defects or other reproductive harm. Some examples of these chemicals are:

- Lead, from lead-based paints
- Crystalline silica from bricks, cement and other masonry products
- Arsenic and chromium, from chemically treated lumber

For further information, consult the following sources:
<http://www.osha.gov/dsg/topics/silicacrystalline/index.html>
<http://www.cdc.gov/niosh/docs/96-112/>
<http://oehha.ca.gov/prop65/law/P65law72003.html>
<http://www.dir.ca.gov/Title8/sub4.html>

Your risk from these exposures varies depending on how often you do this type of work. To reduce your exposure to these chemicals, work in a well-ventilated area, and work with approved safety equipment, such as dust masks that are specially designed to filter out microscopic particles. Where use of a dust extraction device is possible, it should be used. To achieve a high level of dust collection, use an industrial HEPA vacuum cleaner. Observe OSHA 29 CFR part 1926.57 and 1926.103.



WARNING

Sawing, grinding and drilling generate dust. Excessive airborne particles may cause irritation to eyes, skin and respiratory tract. To avoid breathing impairment, always employ dust controls and protection suitable to the material being sawed or drilled; See OSHA (29 CFR Part 1910.1200).

ELECTRICAL REQUIREMENTS AND GROUNDING INSTRUCTIONS

In order to prevent electrical shock and injury, the following electrical safety precautions and symbols should be followed at all times!



WARNING

In case of a malfunction or breakdown, grounding provides a path of least resistance for electrical current to reduce the risk of electric shock. This tool is equipped with an electric cord which has an equipment-grounding conductor and a grounding plug. The plug must be plugged into a matching outlet that is properly installed and grounded in accordance with all local codes and ordinances.

- **DO NOT** modify the plug provided - if it will not fit the outlet, have the proper outlet installed by a qualified electrician.
- Improper connections of the equipment-grounding conductor can result in a risk of electric shock. The equipment-grounding conductor is the insulated conductor that has an outer surface that is green, with or without yellow stripes. If repair or replacement of the electric cord or plug is necessary, **DO NOT** connect the equipment-grounding conductor to a live terminal.
- Check with a qualified electrician or service personnel if the grounding instructions are not completely understood, or if in doubt as to whether the tool is properly grounded.
- Use only 3-wire extension cords that have 3-prong grounding plugs and 3-pole receptacles that accept the tool's plug.
- Repair or replace a damaged or worn cord immediately.

ELECTRIC MOTOR SAFETY

For maintenance care and operation of the electric motor, refer to your electric motor instruction booklet furnished with the electric motor. Protect the electric motor from dust as much as possible and keep ventilating openings clean. Before plugging in the machine, make sure that the outlet voltage is within the voltage marked on the machine's data plate.



CAUTION



DO NOT spray water on the electric motor. **DO NOT** touch the plug with wet hands. To reduce the risk of electrocution, keep all connections dry and off the ground.



DO NOT operate electric motor in an explosive environment.



DO NOT EXPOSE TO RAIN

DO NOT expose to rain or use in damp locations.



WARNING



If operating the equipment in damp locations is unavoidable, **ALWAYS** use a Ground Fault Circuit Interrupter, **ALWAYS** wear rubber gloves and footwear in damp conditions.



DO NOT abuse the cord. Never use the cord to carry the equipment or to pull the plug from the outlet. Keep the cord away from heat, sharp edges, and moving parts. Replace damaged cords immediately. Damaged cords increase the risk of electric shock.



WARNING

To reduce the risk of electrocution, keep all connections dry and off the ground. A Ground Fault Circuit Interrupter (GFCI) should be provided on the circuit(s) or outlet(s) to be used for this machine. Receptacles are available having built-in GFCI protections and may be used for this measure of safety. When using an extension cord, GFCI should be installed closest to the power source, followed by the extension cord and lastly, the machine.



WARNING



Use only extension cords that are intended for outdoor use. These extension cords are identified by a marking "Acceptable for use with outdoor appliances; store indoors while not in use." Use only extension cords having an electrical rating not less than the rating of the product. **DO NOT** use damaged extension cords. Examine extension cords before using and replace if damaged. **DO NOT** abuse extension cords and **DO NOT** yank on any cord to disconnect. Keep cords away from heat and sharp edges. Always disconnect the extension cord from the receptacle before disconnecting the product from the extension cord.

ALWAYS make certain that the power source required for the electric motor is correct and always use the correct NEMA configuration plug. Motors can burn out when the line voltage falls 10% below the voltage rating of the motor. Failure to use proper voltage will cause the motor to overheat. Make certain that the correct size grounded (3-wires) extension cord is used.



WARNING

Use of undersized extension cords result in low voltage to the motor that can result in motor burnout and premature failure. MK Diamond warns that equipment returned to us showing signs of being run in a low voltage condition, through the use of undersized extension cords, will be repaired or replaced totally at the customer's expense. There will be no warranty claim.

To choose the proper extension cord,

- Locate the length of extension cord needed in the table below.
- Once the proper length is found, move down the column to obtain the correct AWG size required for that length of extension cord.

SG-5 MODEL

MOTOR SPECS			EXTENSION CORD LENGTH			
Motor	Voltage	Amps	25'	50'	100'	200'
153288	230V 1 Ph	23	12 ga	12 ga	8 ga	6 ga

SAFETY LABEL LOCATIONS

Safety labels contain important safety information. Please read the information contained on each safety label. These labels are considered a permanent part of your saw. If a label comes off or becomes hard to read, contact MK Diamond or your dealer for a replacement.

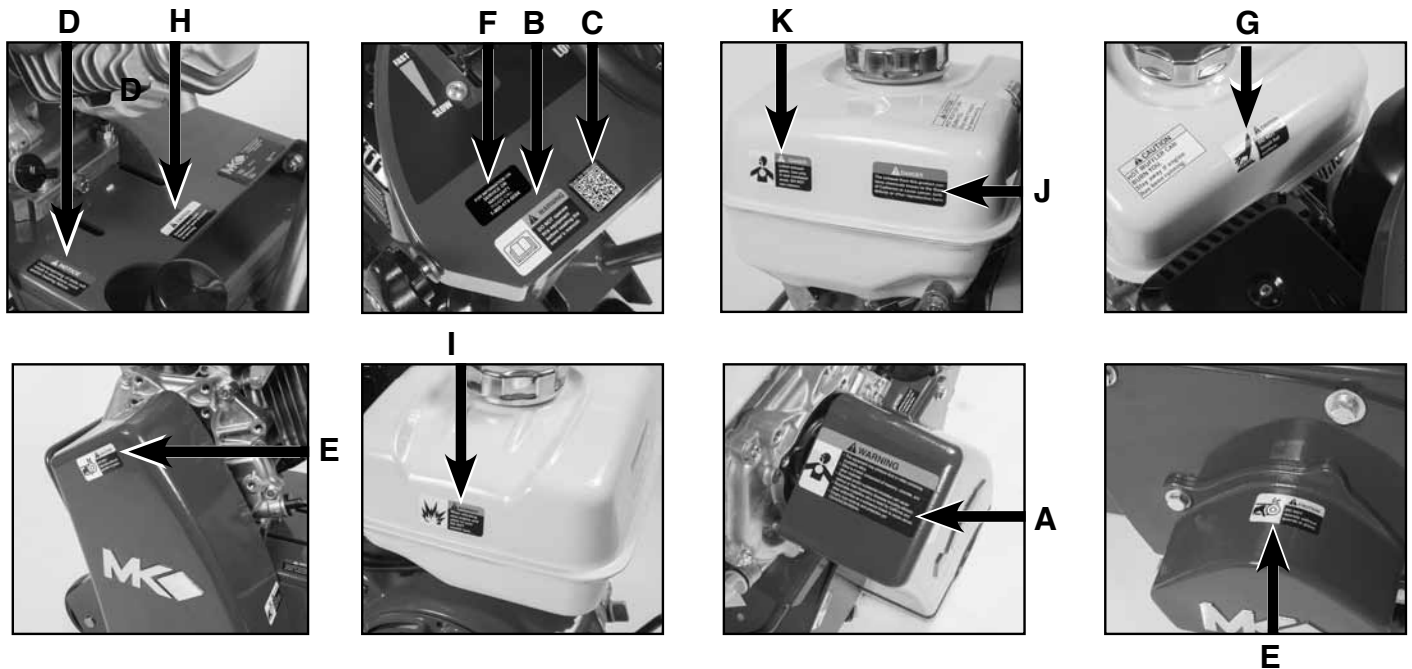
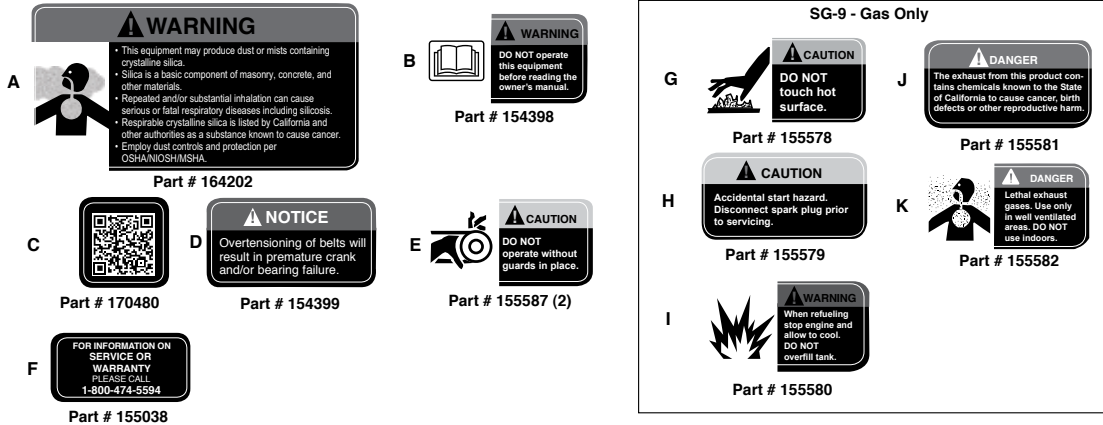

Decal/Label	Location	Description
A	Shaft Guard	Warning - Silica Warning
B	Console	Warning - Read Owner's Manual
C	Console	QR Code for Manual
D	Engine Mount	Notice - Overtensioning of the Belts
E	Belt Guard & Shaft Guard	Caution - Guards in Place
F	Console	Service or Warranty
G	Gas Tank - Top	Caution - Do Not Touch
H	Engine Mount	Caution - Accidental Spark Plug
I	Gas Tank - Side	Warning - Do Not Overfill Tank
J	Gas Tank - Side	Danger - State of California
K	Gas Tank - Side	Danger - Lethal Exhaust

SPECIFIC WARNINGS

- Read Owners Manual
- Wear Protective Gear for Head, Lungs, Ears and Eyes

PRODUCT SPECIFICATION

Operated and used according to this manual, the Scarifier will provide years of dependable service.

General Description

The Scarifiers are is engineered with an 8” Cutting Drum. The SG-9 has a Honda engine and the SG-5 has a Baldor motor. The scarifier is designed with fine depth control allowing the operator to make depth adjustments in 1/16-inch increments.

Motor and Weight Specifications

The Scarifiers use a 6-inch diameter, 8-inch long cutting drum with 6 hardened steel shafts that will accommodate the most common cutting discs.

Model	MK-SG-9	MK-SG-5
Engine/Motor	Honda (Gas)	Baldor (Electric)
Power	GX270 Cyclone	5 HP 230V
Weight (not including drum)	170 lbs. (77kg)	170 lbs. (77kg)
Drum Dimensions (Dia. x L)	6” x 8”	6” x 8”
Drum Weight	30 lbs. (14 kg)	30 lbs. (14kg)
L x W x H (in)	23” x 20” x 43”	23” x 20” x 43”
L x W x H (mm)	813 x 508 x 1,092	813 x 508 x 1,092
Drum Configurations	Part #	Part #
Scarifier with Empty Drum	158532	158533
Scarifier with 5 Point Carbide Drum	158941	165276
Scarifier with 6 Point Carbide Drum	158942	165277
Scarifier with 18 Point Carbide Drum	158943	165278
Scarifier with 12 Point Carbide Drum	158944	165279

Depending on cutting wheel style, production rate varies from 350 to 500 square feet per hour for a 1/8-inch removal depth.

Scarifier Usage

The Scarifier is designed to grind surfaces, remove old coatings, prepare surfaces before applying new coatings, roughen surfaces, groove surfaces and slot surfaces.

Features

- Engage/Disengage Lever allowing the operator to raise or lower the cutting drum without changing the cutting depth setting.
- Ergonomically designed handlebar to reduce fatigue.
- Poly micro V-belt to ensure maximum power transfer from the engine to the cutting drum.

UNPACKING

Your Scarifier has been shipped from the factory thoroughly inspected. Only minimal assembly is required.

If not already done, remove the Scarifier from the pallet and place it on a flat surface (lift the scarifier using the lifting points shown below).

CONTENT

In the containers, you will find one (1) Scarifier, one (1) cutting drum, one (1) owner's manual, one (1) Honda owner's manual and one (1) warranty card.



Scarifier

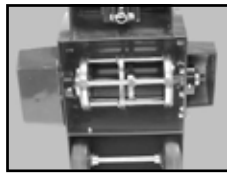

Cutting Drum

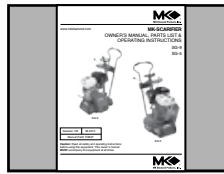

Owner's Manual

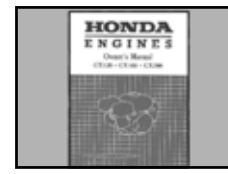

Motor/Engine
Manual



Warranty
Card

TRANSPORT



CAUTION

1. The Scarifier weighs approximately one hundred and eighty-five (185) pounds (with the Cutting Drum assembled the scarifier weighs approximately 230 pounds), use care when transporting.
2. Two people are required to transport the Scarifier.

To lift the scarifier, each person will stand on opposite sides of the Scarifier and grasp the rear Handlebar and the front Handle/Stand to lift, as shown below.

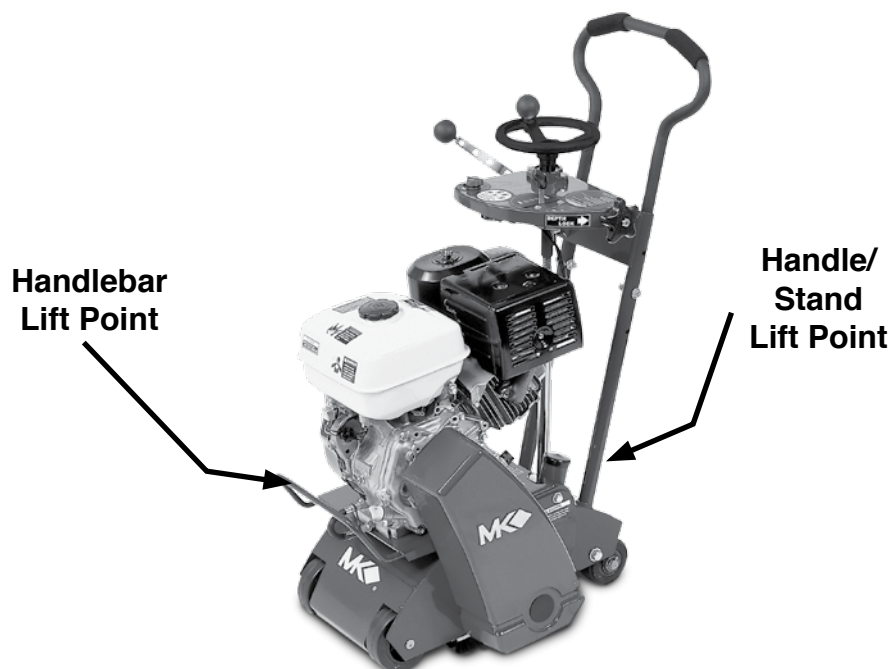

Follow the assembly instructions to prepare your Scarifier for operation.

Handlebar Adjustment

Adjust the Handlebar for ease of operation and comfort of the user.

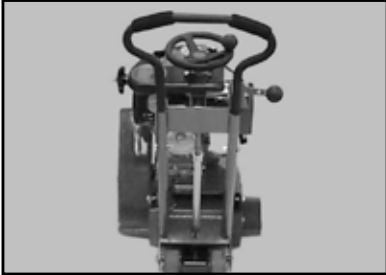

(A)
Locate the Handlebar retaining bolts.

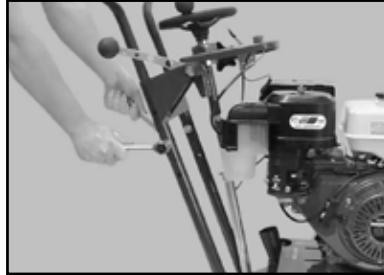

(B)
Remove the Retaining Bolts using 9/16 wrenches and/or sockets.



(C)
Raise or lower the Handlebar as needed.

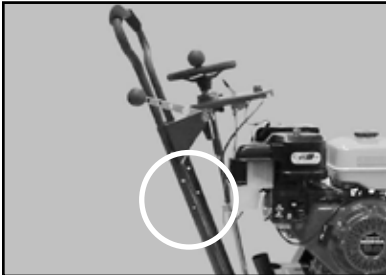

(D)
Align one set of Retaining Bolt holes in the Handlebar to the holes in Scarifier Frame.



(E)
Install the Retaining Bolts and tighten using 9/16 wrenches and/or sockets.

NOTE: Do not rotate saw to rest on handlebar. Engine damage will result.

Scarifier Drum Cutters



Five Tooth Carbide Tip Star Part # 158583

- Used for grinding, leveling, grooving, cleaning, and preparing concrete
- Five-point carbide tips (1-3/4" OD x 5/8" ID x 1/4")
- Longer life than steel tooth cutters, average of 6000 to 8000 square feet
- Maximum cutting rate is 1/8" per pass



Six Tooth Carbide Tip Star Part # 158584

- Used for grinding, leveling, grooving, cleaning, and preparing concrete
- Five-point carbide tips (1-3/4" OD x 5/8" ID x 1/4")
- Exceptional life, average of 8000 to 10000 square feet
- Maximum cutting rate is 1/8" per pass



18 Tooth Steel Sharp Tooth Cutter Part # 158585

- Used for general cleaning of concrete or asphalt including removal of paint, epoxy, urethane, adhesive, and heavy dirt, grease and oil deposits
- 18 tooth hardened steel, (2" OD x 5/8" ID x 1/4")
- Average life of 500 to 800 square feet
- Maximum cutting rate is 1/16" per pass



12 Tooth Steel Blunt Tooth Cutter Part # 158586

- Used for paint and oil removal, traffic and shop floor safety-line removal, cleaning and concrete preparation
- 12 tooth, hardened steel (2" OD x 9/16" ID x 1/4")
- Average life of 500 to 800 square feet
- Maximum cutting rate is 1/16" per pass



Hardened Steel Spacer Part # 158575

- Used to fill empty space between the cutting discs
- 1/2" ID hardened steel

NOTE: The Height Adjustment Hand-wheel will adjust the depth (up or down) of the Cutting Drum by 1/16 of an inch per turn.

Leveling a Surface

- A) Configure the Cutting Drum for Grooving
- B) Locate the lowest spot and highest spot on the surface
- C) Adjust the height of the Cutting Drum to remove approximately 1/16 of an inch from the high spot
- D) Set the Depth Control Lock
- E) Move the Scarifier in a smooth forward motion.
- F) When the Cutting Discs are no longer contacting the surface, return the Scarifier to the starting position
- G) Repeat Steps A through E until the Surface is level (See Figure 1)

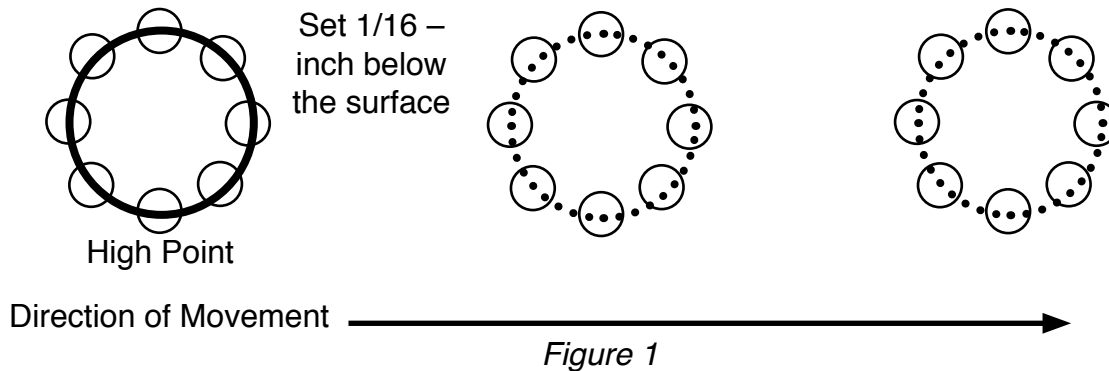

Cutting/Grooving a Surface

- A) Configure the Cutting Drum for Grooving
- B) Adjust the Cutting Drum Depth until the Scarifier is cutting grooves approximately 1/8 of an inch
- C) Move the Scarifier in a smooth forward motion
- D) Should the Cutting Discs loose contact with the surface, repeat Step B and continue forward motion
- E) Repeat Steps A through D until the desired number of grooves are cut (See Figure 2)

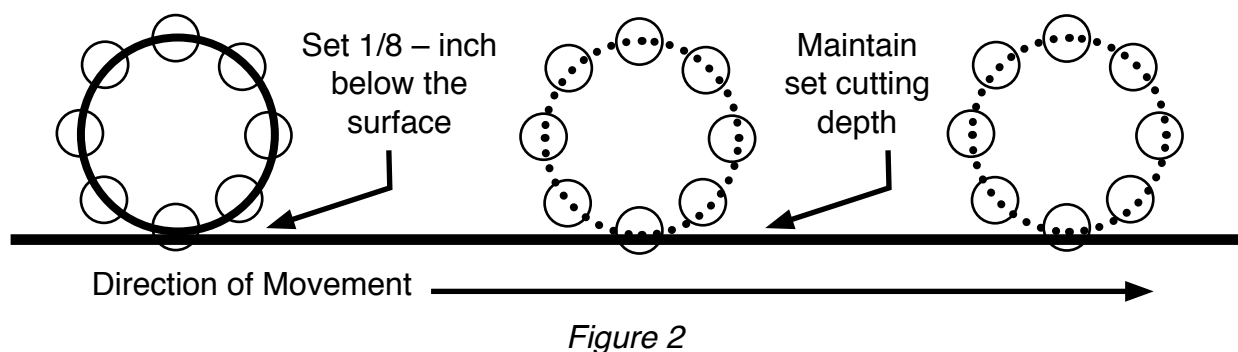

Roughening or Preparing a Surface

- A) Configure the Cutting Drum for Surface Prep.
- B) Adjust the Cutting Drum Depth until the Cutting Discs are contacting the surface (increase the depth of the Cutting Drum as necessary to increase the “roughness of the surface”
- C) Scarifier in a smooth forward motion
- D) Should the Cutting Discs loose contact with the surface, repeat Step B and continue forward motion
- E) Repeat Steps A through D until the desired roughness is achieved. (See Figure 3)

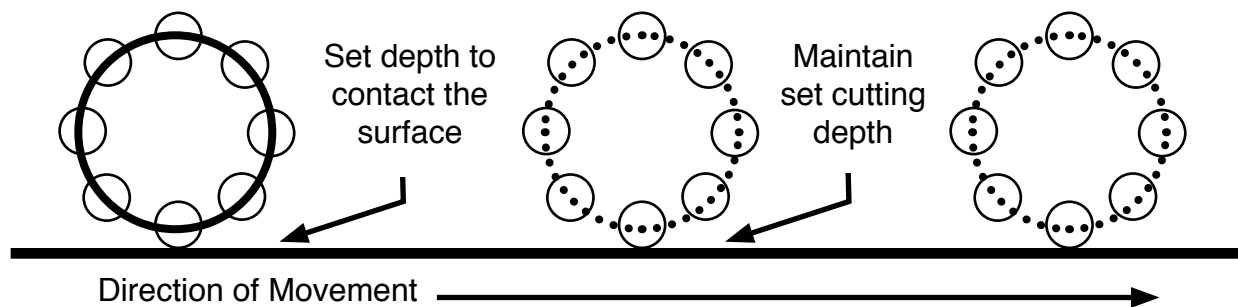
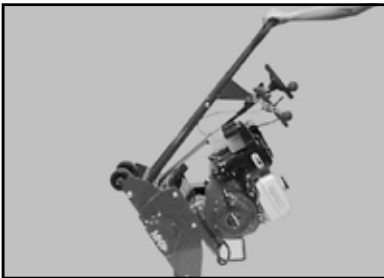

Figure 3

CUTTING DRUM ASSEMBLY

Because the Cutting Drum assembly is a complex process, the assembly procedure will be broken into several parts.

Cutting Drum Removal

(A)
Rotate the Scarifier to rest on the Handle/Stand. Never rest on back handle bar.

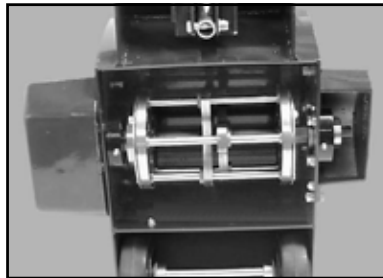

(B)
Locate the Shaft Cover, Retaining Bolts.

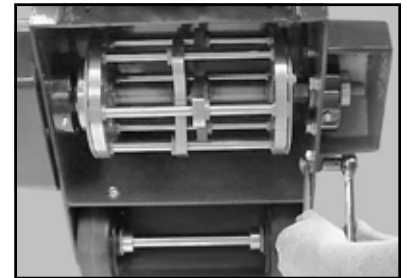

(C)
Remove the Shaft Cover, Rear Retaining Bolt and loosen the Front Retaining Bolt using 9/16 wrenches and/or sockets.

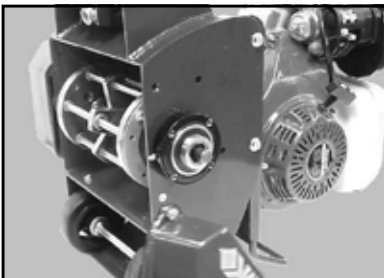

(D)
Pivot the Shaft Cover to expose the end of the Cutting Drum Shaft.



(E)
Remove the Shaft, Retaining Nut Cover from the Belt Guard to expose the Shaft, Retaining Nuts.



(F)
Rotate counterclockwise to using a 15/16-inch socket, loosen the Outer Shaft, Retaining Nut.



(G)
Place an index finger on the end of the Cutting Drum, Shaft



(H)
Remove the Outer Shaft, Retaining Nut using your middle finger as shown



(I)
Repeat Step H for the Inner Shaft, Retaining Nut

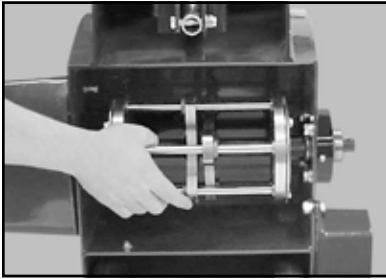

(J)
Grasp the Cutting Drum
as shown.

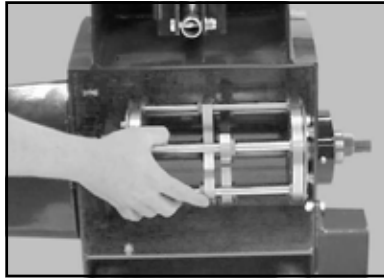

(K)
Push the Cutting Drum away
from the belt side to loosen
the Shaft.

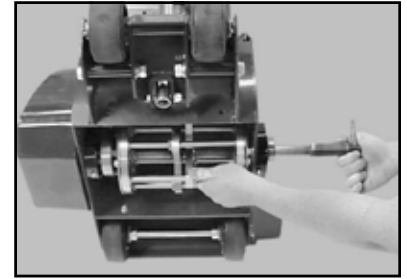

(L)
Place a rod in the hole on the
end of the Shaft, and while
holding the Cutting Drum,
remove the Shaft.

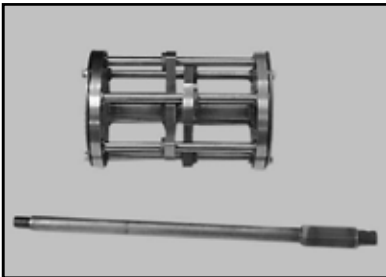

(M)
Remove the Cutting Drum
and Shaft.

NOTE: Assembly is opposite of disassembly

CUTTING DRUM DISASSEMBLY

NOTE: The Cutting Drum may be disassembled from either end.

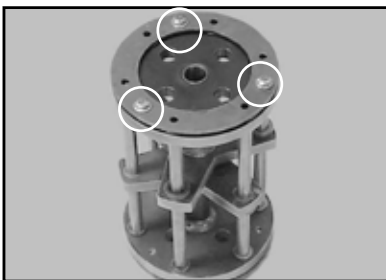

(A)
Rotate the Cutting Drum onto either
end and locate the Retaining Ring,
Retaining Screws.



(B)
Remove the 3 Retaining
Screws using a 7/16-inch
wrench.



(C)
Remove the Drum Retaining
Ring.

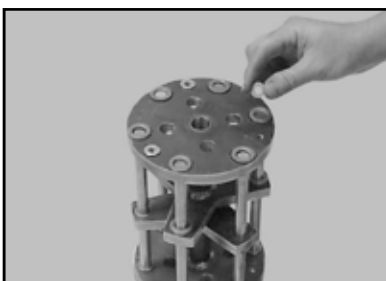

(D)
If present, remove the three
Flat Washer Spacers.

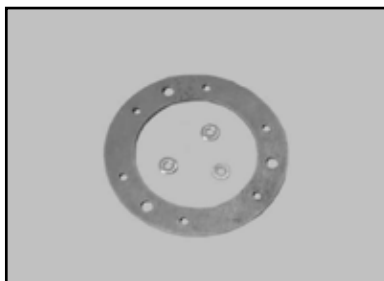

(E)
Place the Retaining Ring and Flat
Washer Spacers in a secure location.

CUTTING DRUM ASSEMBLY

NOTE: The Cutting Drum may be disassembled from either end.

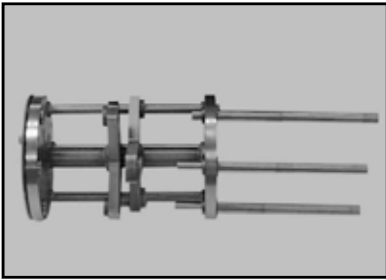

(A)

Pull the Cutting Disc Shafts out the open side of the Cutting Drum as shown.

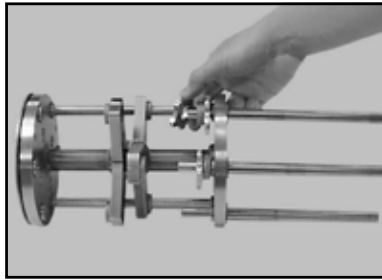

(B)

Assemble the Cutting Drum using Cutting Discs and Disc Spacers (See Cutting Drum Configuration).

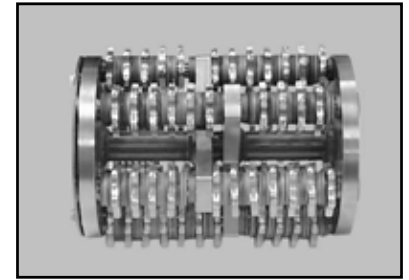

(C)

Continue with Step B until the Cutting Drum assembly is complete.



(D)

Place the Cutting Drum on the closed end, with the open end facing upward.

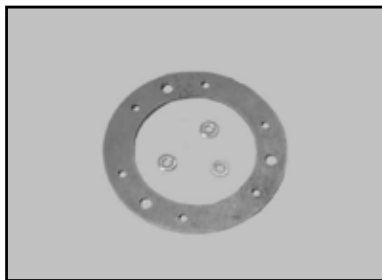

(E)

Obtain the Retaining Ring and Flat Washer Spacers.



(F)

Install the 3 Flat Washer Spacers (if used) over the 3 Retaining Ring, Retaining Screw holes.



(G)

Place the Retaining Ring onto the end of the Cutting Drum, aligning the Retaining Screw Holes.



(H)

Install the 3 Retaining Screws into the Cutting Drum (do not cross-thread the screws).



(I)

Tighten the 3 Retaining Screws using a 7/16-inch wrench.

CUTTING DRUM INSTALLATION

NOTE: The Cutting Drum may be disassembled from either end.

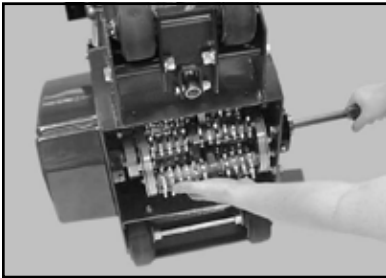

(A)
Install the Cutting Drum; align the Cutting Drum with the Shaft-side Bearing and install the Cutting Drum, Shaft.

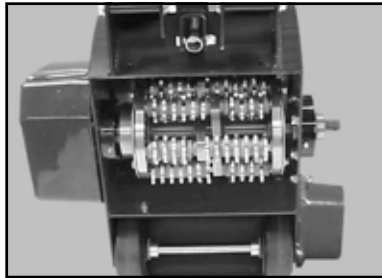

(B)
Verify the Cutting Drum and Shaft are fully installed and seated.



(C)
Install the Shaft, Inner Retaining Nut.



(D)
Using a 15/16-inch socket tighten the Shaft, Inner Retaining Nut, counterclockwise.



(E)
Obtain the Shaft, Outer Retaining Nut.



(F)
Install the Shaft, Outer Retaining Nut.



(G)
Using a 15/16-inch socket tighten the Shaft, Outer Retaining Nut.



(H)
Install the Shaft, Retaining Nut Cover onto the Belt Guard.

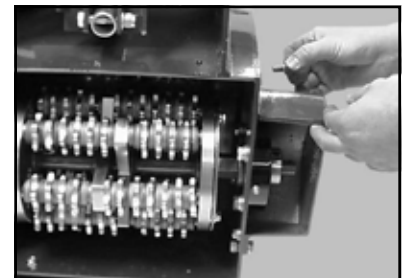

(I)
Pivot the Shaft Guard Cover into position and install the Rear Retaining Bolt.

FILLING OIL RESERVOIR

NOTE: SAE 10W-30 is recommended for general use in temperatures of -4°F (20°C) and above. Engine Oil Capacity is 1.16 US qt (1.1l). Refer to Engine Manual for details.

FILLING FUEL TANK



- WARNING**
1. Gasoline is highly flammable and explosive. You can be burned or seriously injured when handling fuel.
 2. To fuel, stop engine if running, and allow it to cool.
 3. Refuel in a well-ventilated area.
 4. Keep gasoline away from appliance pilot lights, barbecues, electric appliances, power tools, etc.
 5. Wipe up spills immediately.

- NOTES:**
1. Fuel can damage paint and plastic. Be careful not to spill fuel when filling the fuel tank. Damage caused by spilled fuel IS NOT covered under the warranty.
 2. DO NOT use stale or contaminated gasoline, or an oil/gasoline mixture.
 3. Use unleaded gasoline with a pump octane rating of 86 or higher.

NOTE: Refer to Engine Manual for details.

VACUUM SETUP FOR OPERATION

The Scarifier is designed for use with a vacuum. MK Diamond recommends using a vacuum to reduce the amount of dust generated during operation.

MK Diamond does not endorse any specific vacuum type, but does recommend the customer use the Scarifier with a dry dust collector (designed for wood dust) as opposed to a standard wet/dry vacuum.



(A)

Obtain a vacuum or dust collection system.



(B)

Remove the Cap from the Vacuum Connection Point.



(C)

Using a 2 1/2-inch hose, connect the Vacuum to the Scarifier at the Vacuum Connection Point.



(D)

Verify the hose connections are secure at the Scarifier and the Vacuum.

Pre-start Inspection

The pre-start inspection should be performed before beginning any job. If Cutting Discs are worn, or are missing carbide inserts (carbide cutting discs only), replace the discs before starting work.

- NOTE:**
- **DO NOT** rotate Scarifier to rest on handlebar. Engine damage will result.
 - The carbide tips on carbide cutting discs are approximately 1/4-inch in length. When the carbide disc is worn to the end of the carbide tip, the tip may fall out leaving a small hole.

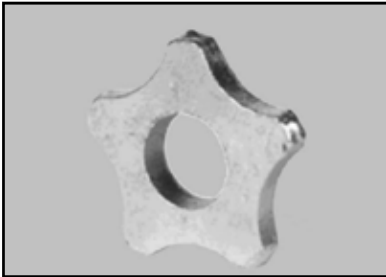

(A)

Inspect the Cutting Discs for excessive wear and missing tips.



(B)

Inspect Engine for leaks.



(C)

Inspect the Scarifier for general damage and/or loose hardware.



(D)

Verify the Height Adjusting Wheel moves freely and moves up and down smoothly.



(E)

Verify the Scarifier rolls freely.

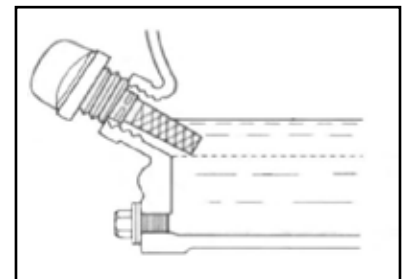

(F)

Check for proper oil level (See Engine Manual).

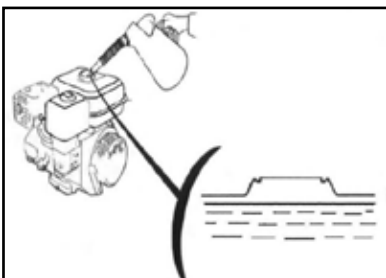

(G)

Check for proper fuel level (See Engine Manual).



(H)

Check Air Filter for cleanliness (See Engine Manual).

START-UP



- WARNING**
1. Carbon monoxide gas is toxic, breathing it can cause unconsciousness and/or death.
 2. Avoid any areas or actions that expose you to carbon monoxide.

NOTE: If restarting a warm engine, leave the Choke Lever in the OPEN position.
The Scarifier is capable of performing several different operations simply by changing drum configuration. The following steps describe how it is operated in any configuration.

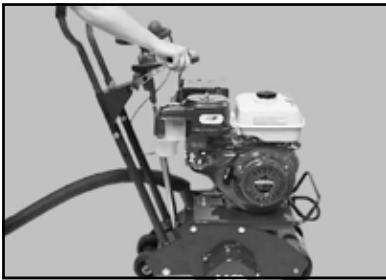

(A)

Verify the Engage/Disengage Lever is in the "Lift" position.



(B)

Raise the Cutting Drum to the highest position.



(C)

Place Motor/Engine Switch in the ON position. See Engine Manual for complete start-up procedures.

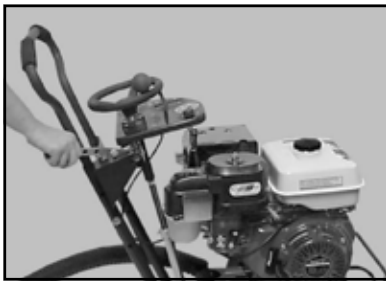

(D)

Place the Engage/Disengage Lever in the "Lower" position.



(E)

Adjust the speed by using the Throttle, as desired.



(F)

Adjust the height of the Cutting Drum for the Job being performed (See Basic Grinding Techniques).



(G)

Lock the height of the drum using the Depth Control Lock. Start the work.

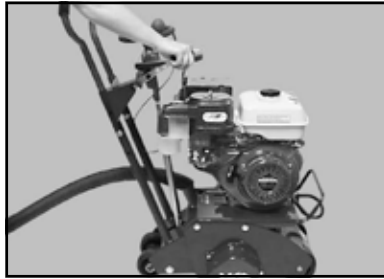

(H)

Place the Engage/Disengage Lever in the "Lift" position when the work is complete.

NOTE: When turning the Scarifier, lift the Rear Wheels off the ground, and pivot it on the Front Wheels.

Normal Engine Shutdown

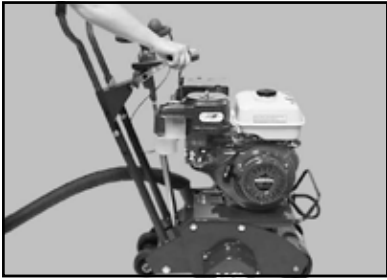

(A)

Verify the Engage/Disengage Lever is in the "Lift" position.

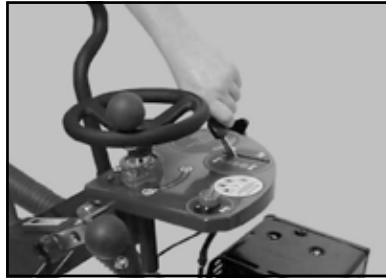

(B)

Move the Throttle Lever to idle.

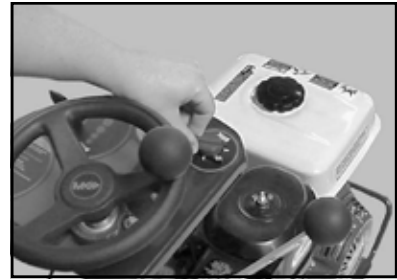

(C)

Place Motor/Engine Switch in the OFF position.

NOTE: In an emergency, place Engine Master Switch in the OFF position.

CLEANUP

Engine parts are extremely hot following use, allow engine to cool 1/2-hour before cleaning. Use care during cleanup to avoid injury.

- NOTES:**
1. To extend operating life, the scarifier should be cleaned following every use.
 2. Using a garden hose or pressure washer can force water into the air cleaner or muffler opening.
 3. Use care when cleaning around electrical components.



(A)

Clean the Scarifier with soap and water.



(B)

Verify the engine is off and cool before beginning to clean.

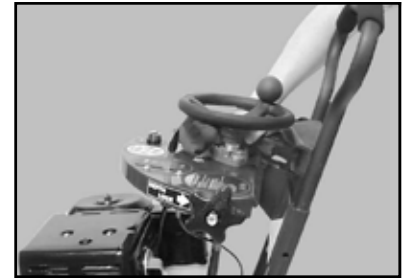

(C)

Clean around the Depth Control Wheel bearing.



(D)

Clean the Depth Control Screw.

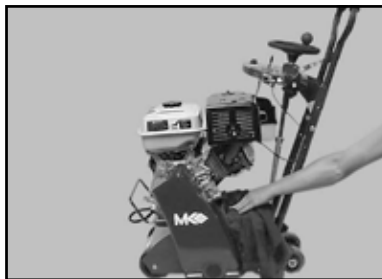

(E)

Clean the remainder of the exterior surface of the scarifier (except the engine).

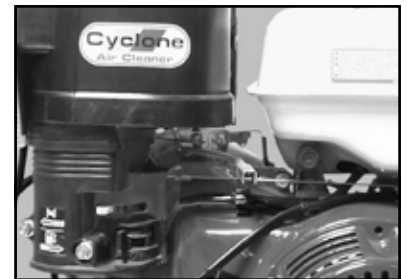

(F)

Clean engine throttle linkage with a dry cloth.

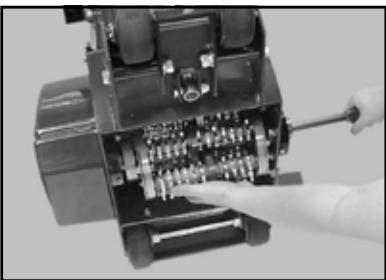

(G)

Remove the Cutting Drum (See Setup Section).

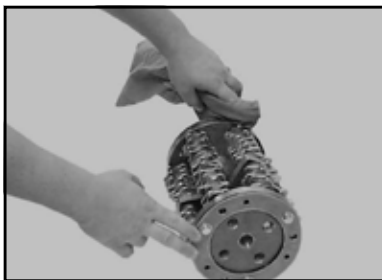

(H)

Clean the Shaft Penetration Hole of the Cutting Drum.

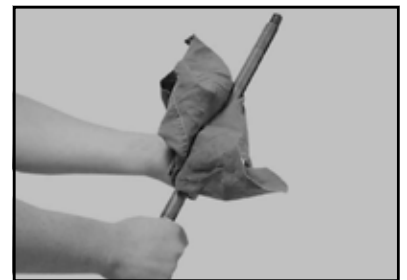

(I)

Clean the Cutting Drum, Shaft.

New Maintenance

Perform the following after initial purchase and operation of the saw.

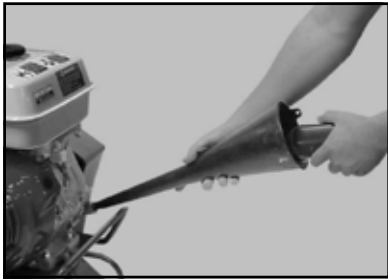

(A)

Change engine oil after 1st month or 1st 20 operating hours (See Engine Manual).

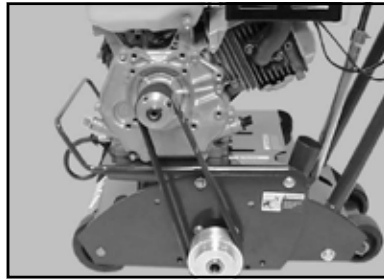

(B)

Check and adjust tension on all V-belts following 1st 48 hours of operation (See V-belt Inspection).

Maintenance Following Use

The following maintenance should be performed following each use. Use Light oil, such as WD-40 or 3 in 1 when lubricating parts.

NOTES: Due to the material used in the Cutting Drum and Shaft, it is critical that Steps C and D be performed.



(A)

Shutdown the Engine (See Normal Engine Shutdown).



(B)

Check Air Filter for cleanliness (See Engine Manual).

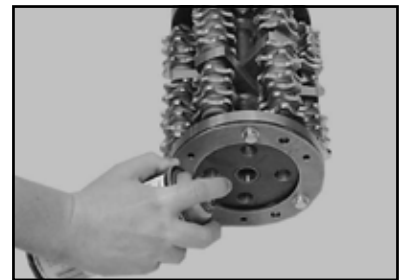

(C)

Lubricate arbor in drum. Clean engine throttle linkage with a dry cloth.



(D)

Lubricate the Cutting Drum Shaft.

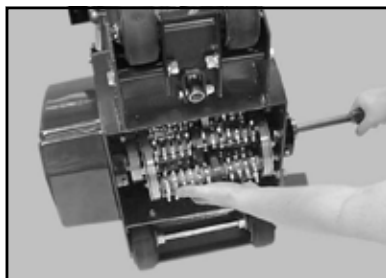

(E)

Reinstall the Cutting Drum.

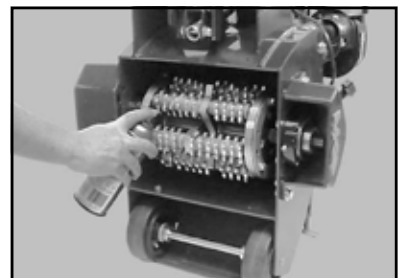

(F)

Lubricate the outer surface of the Cutting Drum.

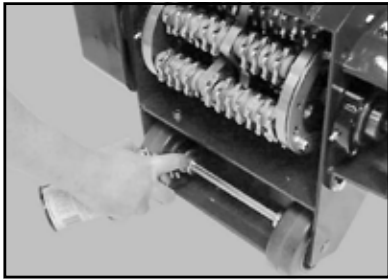

(G)
Lubricate the Front Wheel Assembly.

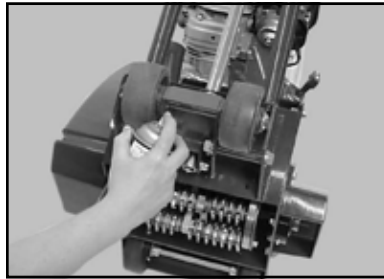

(H)
Lubricate the Rear Wheel Assembly.



(I)
Lubricate the Engage/ Disengage Pivot Shaft.



(J)
Lubricate and clean the Depth Control Screw.



(K)
Lubricate engine Throttle Linkage.

Monthly Maintenance

The following should be performed monthly. Items should be lubricated using a waterproof grease.



(A)
Verify the tightness of all bolts and screws.

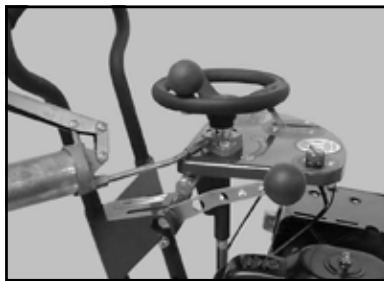

(B)
Lubricate the Height Adjusting Wheel Bearing.

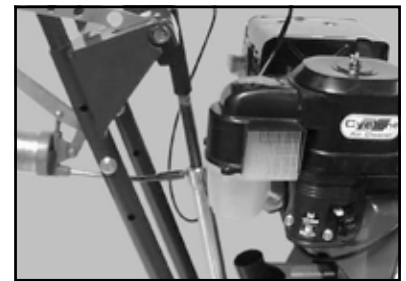

(C)
Lubricate the Depth Control Screw.

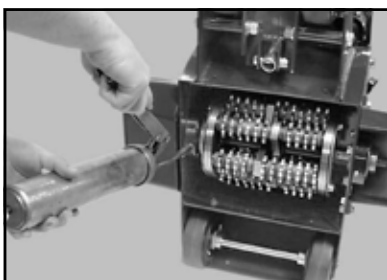

(D)
Lubricate the Cutting Drum, Shaft Bearings.



(E)
Lubricate the Front Wheel Assembly Bearings.



(F)
Clean engine Air Filter (See Engine Air Filter Inspection Cleaning and Replacement).

Six (6) Month Maintenance

Perform the following maintenance every six months.

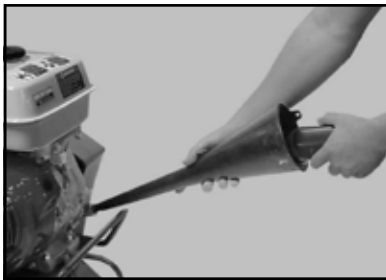

(A)
Change engine oil
(See Engine Manual).

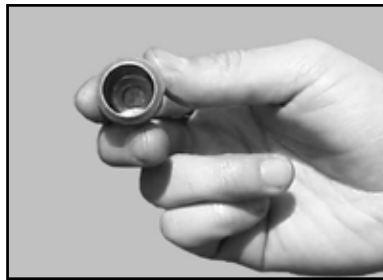

(B)
Clean Fuel Sediment Cup
(See Fuel Sediment Cup
Cleaning).



(C)
Clean and Readjust engine
Spark Plug
(See Engine Manual).

Yearly and Two-Year Maintenance

Perform the following maintenance every year.



(A)
Replace engine Air Filter
(See Engine Manual).



(B)
Replace Spark Plug
(See Engine Manual).

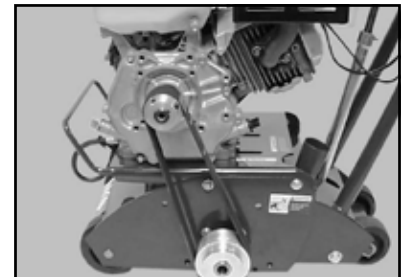

(C)
Inspect V-belts
(See V-Belt Inspection, Adjust-
ment and Replacement).



(D)
Check/Adjust Idle Speed
Check/Adjust Valve Clear-
ance (Shop Maintenance
Required).



(E)
Check Fuel Line (2-Year
Maintenance Only, Shop
Maintenance Required).

Check Fuel Level



- WARNING**
1. Gasoline is highly flammable and explosive. You can be burned or seriously injured when handling fuel.
 2. To fuel, stop engine if running and allow it to cool.
 3. Refuel in a well-ventilated area.
 4. Keep gasoline away from appliance pilot lights, barbecues, electric appliances, power tools, etc.
 5. Wipe up spills immediately.

- NOTES:**
1. Fuel can damage paint and plastic. Be careful not to spill fuel when filling the fuel tank. Damage caused by spilled fuel is not covered under the warranty.
 2. **DO NOT** use stale or contaminated gasoline or an oil/gasoline mixture.
 3. Use unleaded gasoline with a pump octane rating of 86 or higher.

NOTE: Refer to Engine Manual for details.

Checking Oil Level

- NOTES:**
1. Engine Oil Capacity is 1.16 US qt (1.1 l).
 2. When installing the Oil Dipstick, ensure the threads are aligned with the threads of the Oil Reservoir so as not to “cross-thread.”

NOTE: Refer to Engine Manual for details.

Changing Oil

Oil is a major factor affecting performance and service life. Use 4-stroke automotive detergent oil. Refer to Engine Manual for specific procedures. SAE 10W-30 is recommended for general use. Other viscosity oil shown in the chart below may be used when the average temperature in your area is within the recommended range.

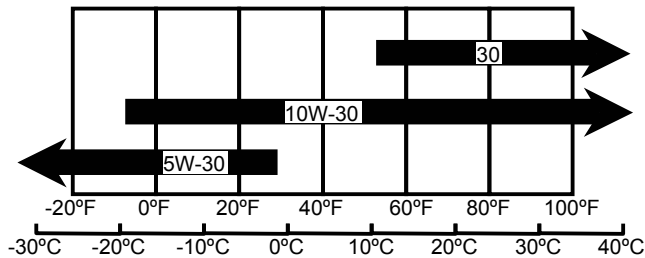

- NOTES:**
1. Drain used oil while the engine is warm.
 2. Conform to Federal, State and Local laws, codes and ordinances relative to environmental protection for oil disposal.

NOTE: Refer to Engine Manual for details.



(A) Lower the Scarifier to its lowest position.

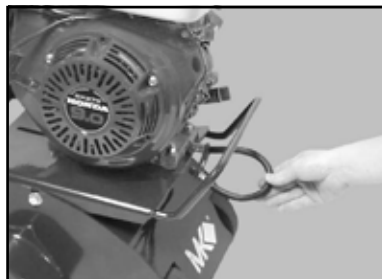

(B) Free the Oil Drain Line.

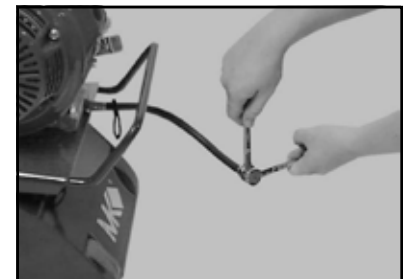

(C) Place a catch basin below the Oil Drain Line and remove the Drain Cap using two 1/2 –inch wrenches.



(D) Drain Oil the engine oil (conform to Federal, State and Local laws for disposal).

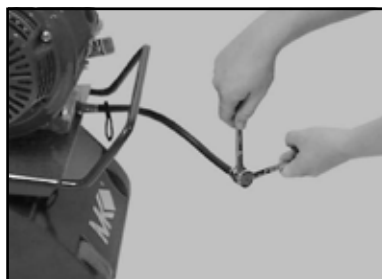

(E) Using two 1/2 – inch wrenches, install the Drain Cap onto the Oil Drain Line (Ensure the Cap is tight).



(F) Fill the Oil Reservoir (See Engine Manual).

Fuel Sediment Cup Cleaning

**WARNING**

1. Gasoline is highly flammable and explosive. You can be burned or seriously injured when handling fuel.
2. To fuel, stop engine if running and allow it to cool.
3. Refuel in a well-ventilated area
4. Keep gasoline away from appliance pilot lights, barbecues, electric appliances, power tools, etc.
5. Wipe up spills immediately.

NOTES:

1. Conform to Federal, State and Local laws for the proper disposal of fuel
2. Fuel can damage paint and plastic. Be careful not to spill fuel when filling the fuel tank. Damage caused by spilled fuel IS NOT covered under the warranty.
3. DO NOT use stale or contaminated gasoline or an oil/gasoline mixture.
4. When installing the Sediment Cup retaining bolt, ensure the threads of the bolt are aligned with the threads on the Fuel Valve so as not to “cross-thread the nut.”



(A)

Place Fuel Valve in the OFF position.

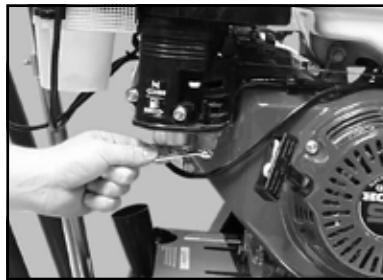

(B)

Loosen the Fuel Sediment Cup. (See Engine Manual for details)

Spark Plug Adjustment and Replacement

**CAUTION**

DO NOT work around the engine while hot.

NOTES:

1. When installing the Spark Plug, ensure the threads of the plug are aligned with the threads in the engine so as not to “cross-thread” the plug.
2. See Engine Manual for specific details.

Engine Air Filter Inspection Cleaning and Replacement

Refer to Engine Manual.

Cutting Drum Change-out



WARNING

Disconnect the tool before servicing and when changing accessories, such as blades, bits, cutters, and the like.

NOTE:

DO NOT Rotate saw to rest on handlebar. Engine damage will result.

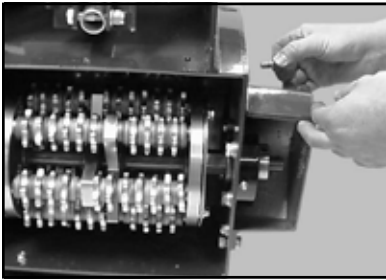

(A)

Remove the Shaft Cover, Rear Retaining Bolt and loosen the Front Retaining Bolt using 9/16 wrenches and/or sockets.

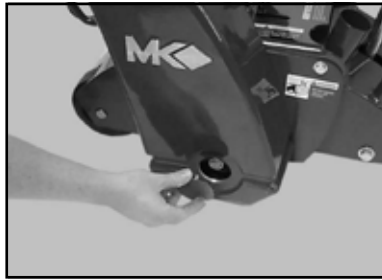

(B)

Remove the Shaft, Retaining Nut Cover from the Belt Guard to expose the Shaft, Retaining Nuts.

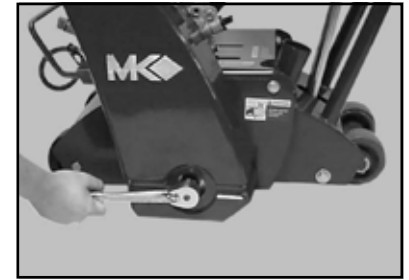

(C)

Using a 15/16-inch socket, loosen the Outer Shaft, Retaining Nut. Retaining Nuts are left hand threaded.



(D)

Place an Index Finger on the end of the Cutting Drum, Shaft.



(E)

Remove the Outer Shaft, Retaining Nut using your Middle Finger as shown.



(F)

Repeat Step C through E for the Inner Shaft, Retaining Nut.

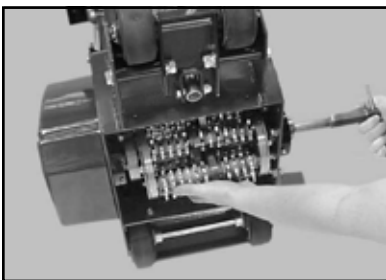

(G)

Remove the Cutting Drum and Shaft.

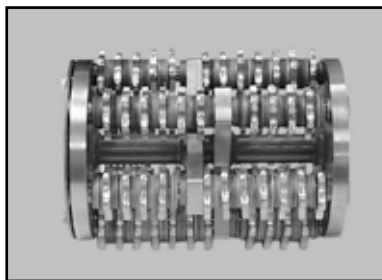

(H)

Reconfigure the Cutting Drum as needed.

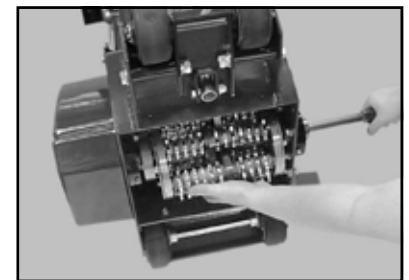

(I)

Install the Cutting Drum into the Scarifier; align the Cutting Drum with the Shaft-side Bearing and install the Cutting Drum, Shaft.

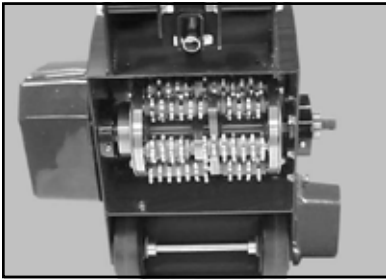

(J)
Verify the Cutting Drum and Shaft are fully installed and seated.



(K)
Install the Shaft, Inner Retaining Nut.

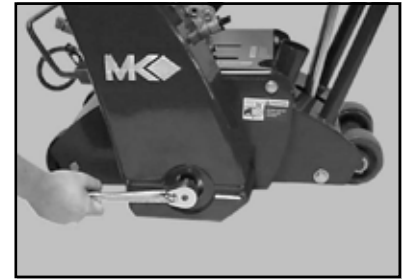

(L)
Using a 15/16-inch socket tighten the Shaft, Inner Retaining Nut.



(M)
Obtain the Shaft, Outer Retaining Nut.



(N)
Install the Shaft, Outer Retaining Nut.

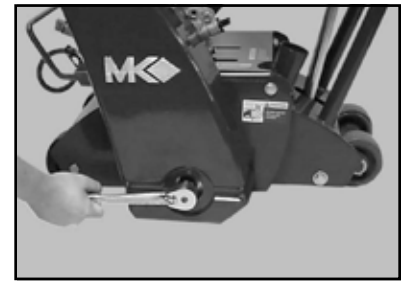

(O)
Using a 15/16-inch socket tighten the Shaft, Outer Retaining Nut.

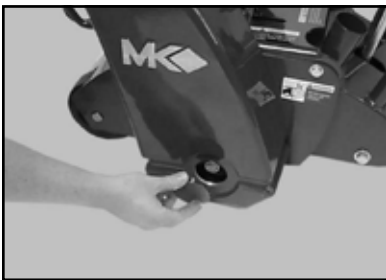

(P)
Install the Shaft, Retaining Nut Cover onto the Belt Guard.

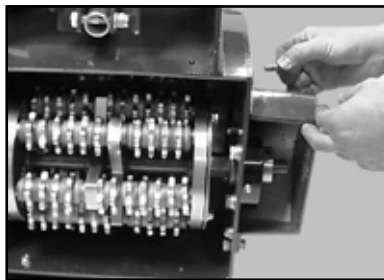

(Q)
Pivot the Shaft Guard Cover into position and install the Rear Retaining Bolt.

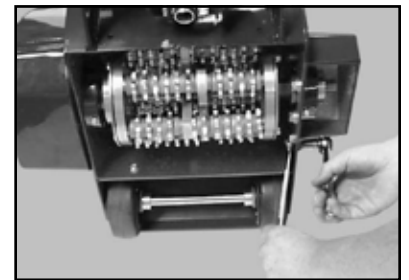

(R)
Tighten the Shaft Guard Cover Retaining Bolts using 9/16 wrenches and/or sockets.

Reconfigure the Cutting Drum

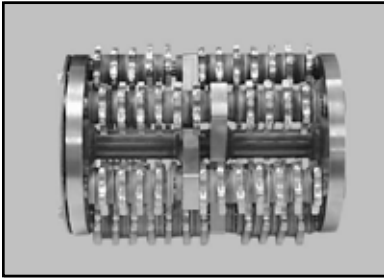

(A)
Remove the Cutting Drum (See Cutting Drum Change-out).

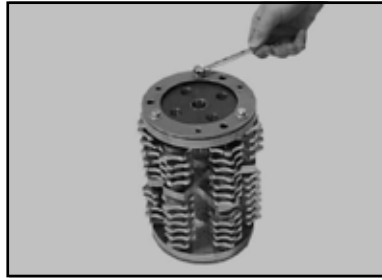

(B)
Place the Cutting Drum on end and remove the 3 Retaining Screws using a 7/16-inch wrench.

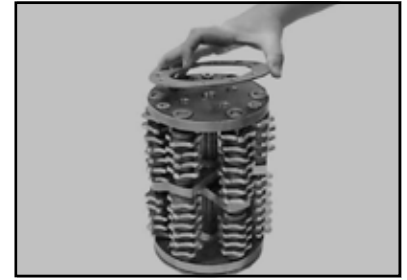

(C)
Remove the Retaining Ring from the Cutting Drum.



(D)
If present, remove the three Flat Washer Spacers.

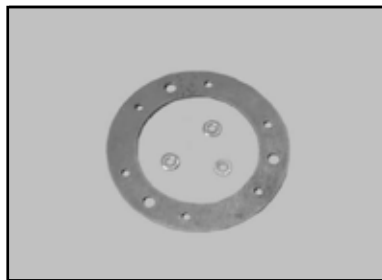

(E)
Place the Retaining Ring and the 3 Flat Washer Spacers in a secure location.

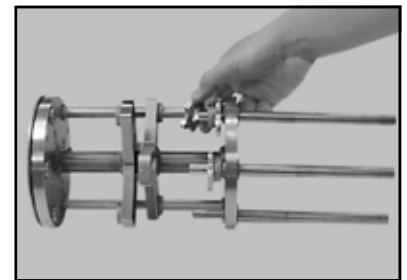

(F)
Pull the Cutting Disc Shafts and remove the Cutting Discs and Disc Spacers.

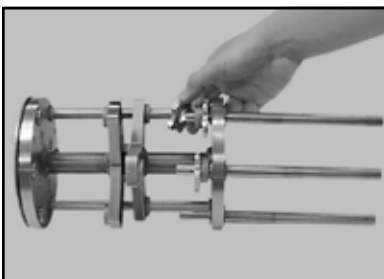

(G)
Assemble the Cutting Drum using Cutting Discs and Disc Spacers (See Cutting Drum Configuration).

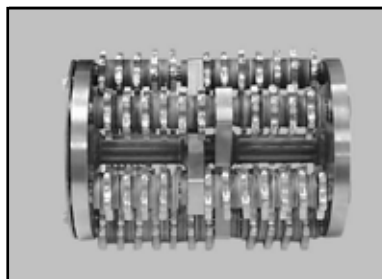

(H)
Continue with Step B until the Cutting Drum assembly is complete.



(I)
Place the Cutting Drum on the closed end, with the open end facing upward.

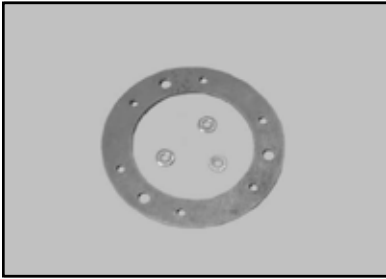

(J)

Obtain the Retaining Ring and Flat Washer Spacers.



(K)

Install the 3 Flat Washer Spacers (if used) over the 3 Retaining Ring, Retaining Screw holes.

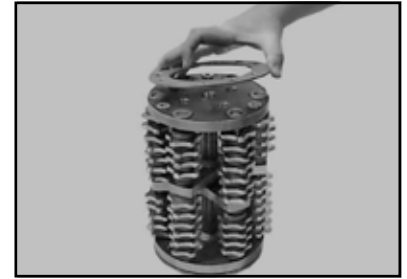

(L)

Place the Retaining Ring onto the end of the Cutting Drum, aligning the Retaining Screw Holes.



(M)

Install the 3 Retaining Screws into the Cutting Drum (do not cross-thread the screws).



(N)

Tighten the 3 Retaining Screws using a 7/16-inch wrench.

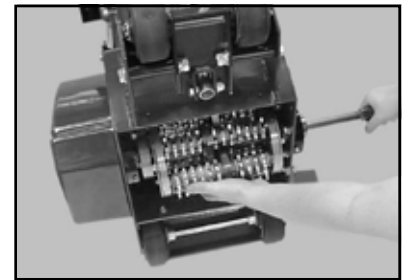

(O)

Install the Cutting Drum (See Cutting Drum Change-out).

Dust Screen Brush Change Out

NOTE: The four (4) Brushes should be replaced at the same time (MK Diamond Part # 160300).

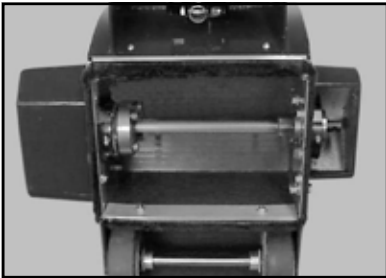

(A)
Inspect the Dust Screen
Brushes for wear.

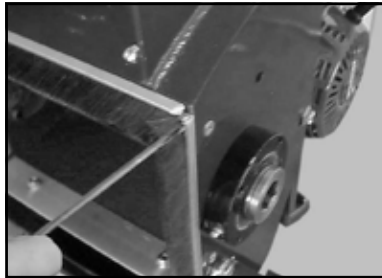

(B)
Loosen the end of each
Brush Holder with a Flat
Blade Screwdriver.

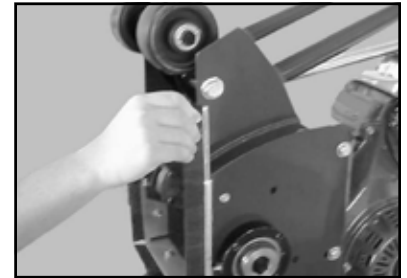

(C)
Slide each Brush out of its
Brush Holder.



(D)
Obtain Replacement
Brushes.

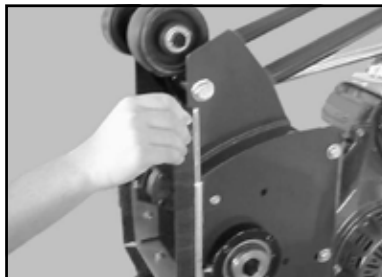

(E)
Slide the new Brushes into
the Brush Holders.

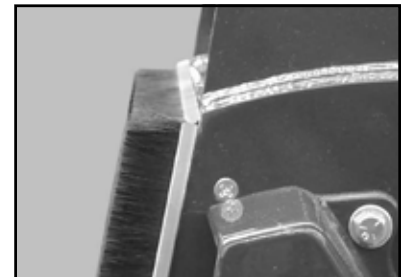

(F)
Pinch the end of the Brush
Holders to hold each Brush in
place.

Front Wheel Change Out

NOTE: The two (2) Front Wheels should be replaced at the same time (MK Diamond Part # 138529).

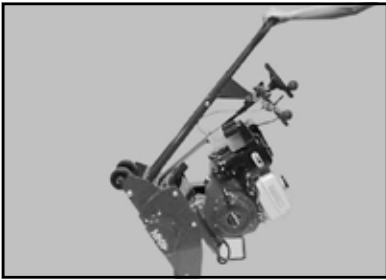

(A)

Rotate the Scarifier to rest on the Handle/Stand.

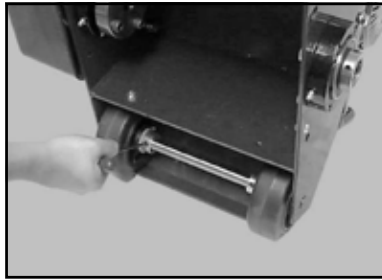

(B)

Loosen the Retaining Collar of each Wheel using a 5/32-inch Allen Wrench.

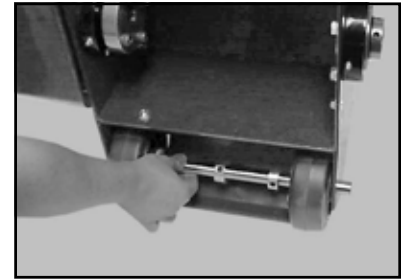

(C)

Move the Retaining Collars toward the center of the Axle and then slide the Axle out of the Scarifier.

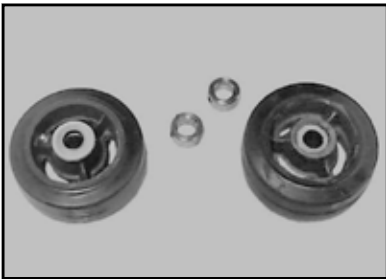

(D)

Obtain 2 replacement Wheels and remove the Dust Cover from one side of each Wheel.

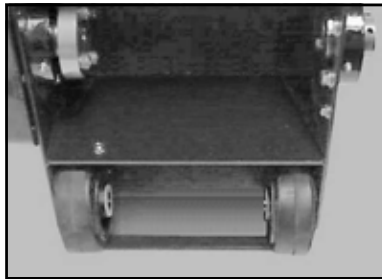

(E)

Seat the Front Wheels into the Wheel-well with the Dust Cover side facing inward.

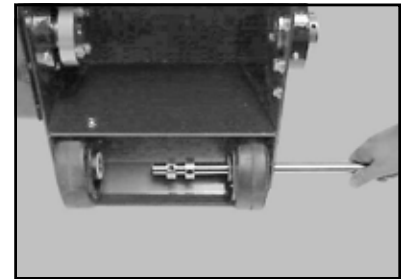

(F)

Slide the Axle through one Wheel, Install the 2 Retaining Collars and then slide the Axle through the second Wheel.

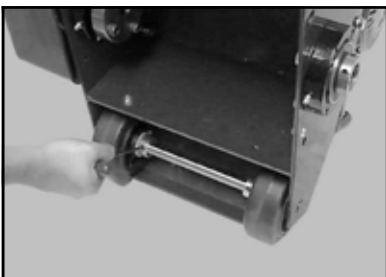

(G)

Push the Retaining Collars against the Front Wheels and then tighten them with a 5/32-inch Allen Wrench.

Rear Wheel Change Out

NOTE: The two (2) Rear Wheels should be replaced at the same time (MK Diamond Part # 158520).

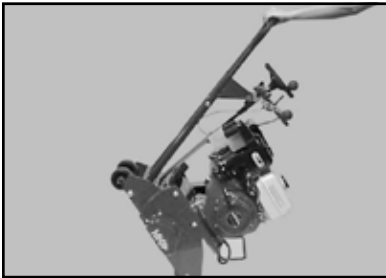

(A)
Rotate to rest on the Handle/
Stand.

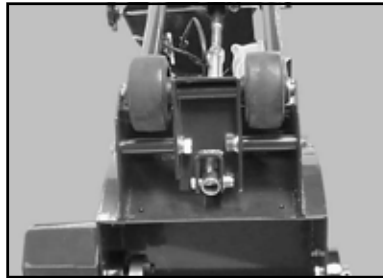

(B)
Locate the Rear Wheel
Truck Assembly.

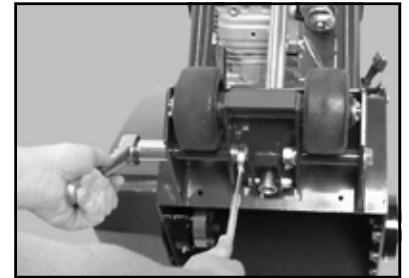

(C)
Remove the Rear Wheel
Truck Assembly Retain-
ing Nuts using 3/4-inch
wrenches.

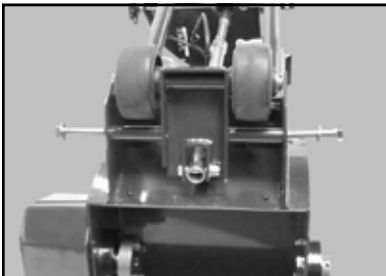

(D)
Remove the Rear
Wheel Truck Assembly Re-
taining Bolts.

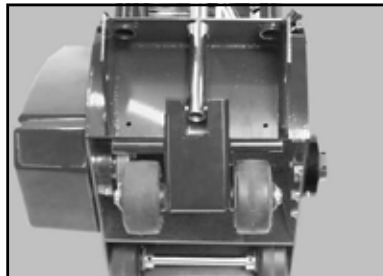

(E)
Lower the Rear Wheel Truck
Assembly.



(F)
Remove the Rear Wheel
Retaining Cotter Pin, Shim
Washer and Rear Wheel from
each side of the Assembly.

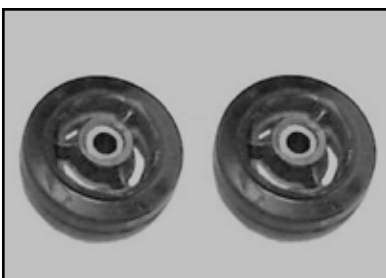

(G)
Obtain replacement wheels.



(H)
Install the new Rear Wheel,
Shim Washer and Cotter Pin
on each side of the Assem-
bly.

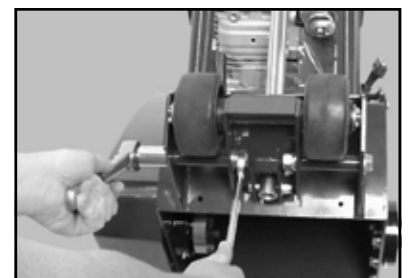

(I)
Install the Rear Wheel Truck
Assembly Retaining Nuts
and Bolts removed in Steps C
and D using
3/4-inch wrenches.

V-Belt Inspection, Adjustment and Replacement

In order to ensure the Scarifier operates at peak efficiency, the power transmission V-belt should be inspected monthly and changed if any signs of damage and/or excessive wear is observed.

NOTE: When a new belt is installed, it should be inspected and re-tensioned after the first forty-eight (48) hours of operation.

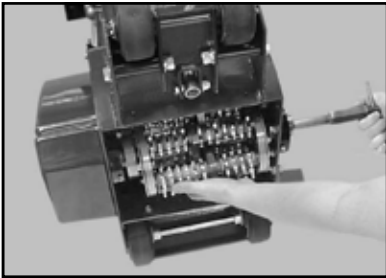

(A)
Remove the Cutting Drum (See Cutting Drum Change-out).

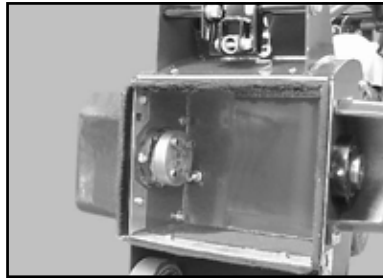

(B)
Locate and remove the Belt Guard Retaining Screws using a 9/16-wrench.

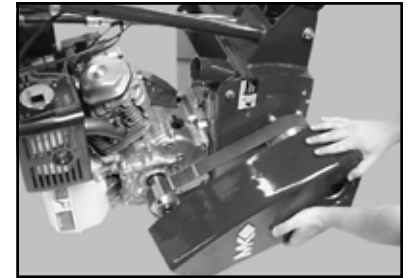

(C)
Remove the Belt Guard.

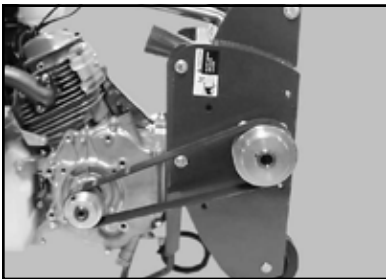

(D)
Inspect the V-belt for excessive wear, cracks and cuts – if worn, proceed to step F.

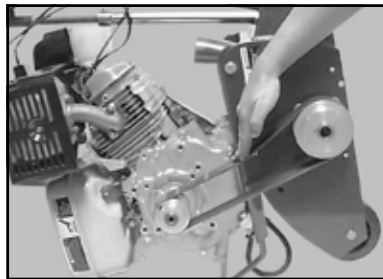

(E)
Check V-belt for proper tension, if tension correct, go to step O (proper tension is 1/2-inch deflection of the belt).

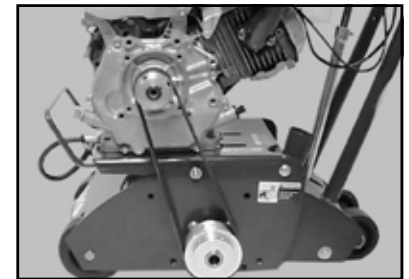

(F)
Locate the Engine Mounting Plate Bolts on both sides.

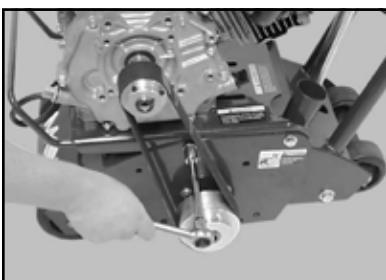

(G)
Loosen the Front Engine Mounting Plate Bolts on both sides using a 9/16-inch wrench.

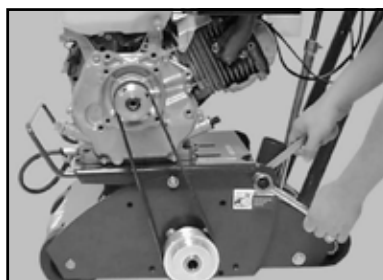

(H)
Loosen the Rear Engine Mounting Plate Bolts on both sides using a 9/16-inch wrench.



(I)
Locate the V-belt Adjusting Screw Lock Nut inside the Cutting Drum Well. Loosen the nut using a 9/16-inch wrench.

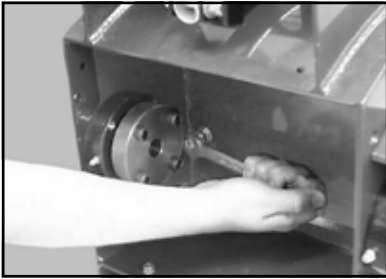

(J)
Locate the V-belt Adjusting Screw inside the Cutting Drum Well. Loosen the screw using a 9/16-inch wrench.

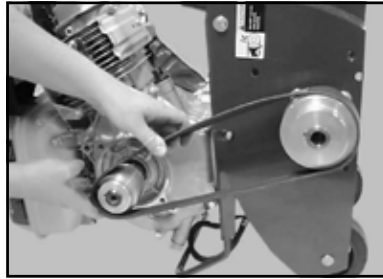

(K)
Remove the V-belt from the Engine and Cutting Drum Pulleys.

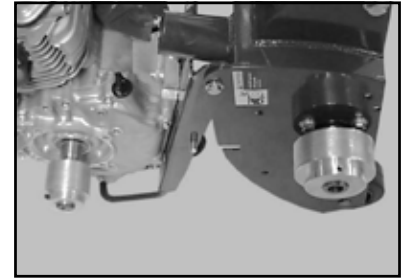

(L)
Clean and verify the alignment of the Engine and Cutting Drum Pulleys.

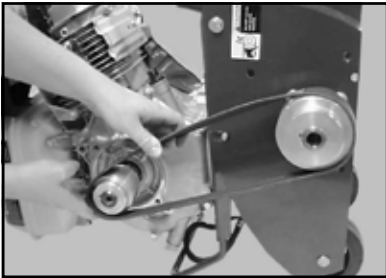

(M)
Obtain and install a new V-belt onto the Engine and Cutting Drum Pulleys.



(N)
Verify the V-belt is seated in all grooves of the Engine and Cutting Drum Pulleys.

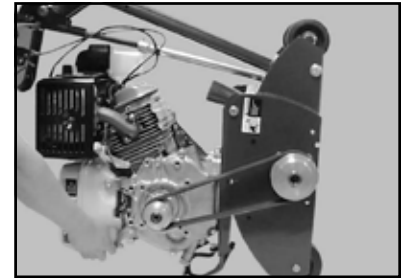

(O)
Pull the front of the Engine Mounting Plate away from the Frame to tension the V-belt.

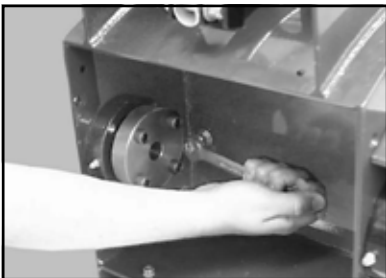

(P)
Tighten the V-belt Adjusting Screw one turn using a 9/16-inch wrench.

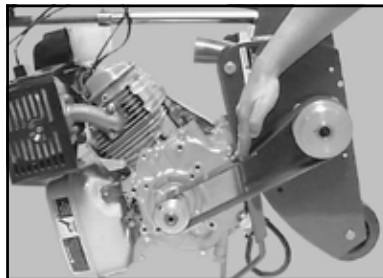

(Q)
Verify the tension of the V-belt (proper tension is 1/2-inch deflection of the belt).

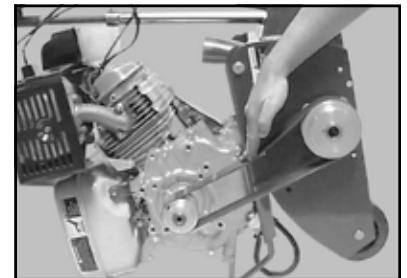

(R)
Repeat Steps P and Q until proper tension has been reached (proper tension is 1/2-inch deflection of the belt).

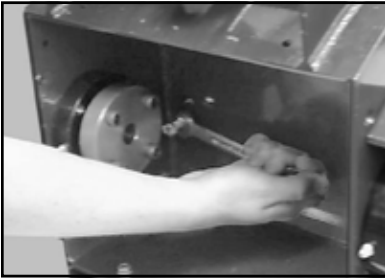

(S)

Tighten the V-belt Adjusting Screw Lock Nut using a 9/16-inch wrench.

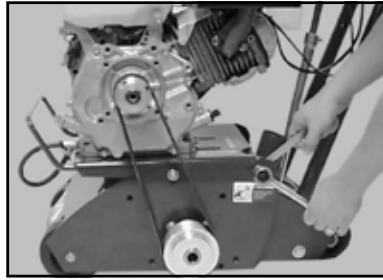

(T)

Tighten the Engine Mounting Plate Bolts on both sides using a 9/16-inch wrench.

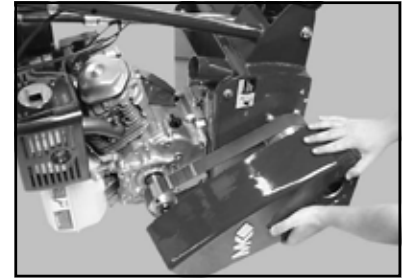

(U)

Install the Belt Guard.

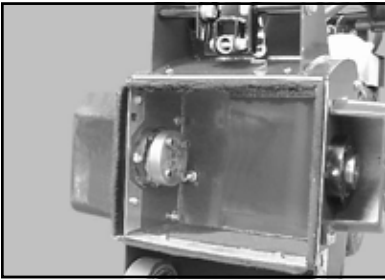

(V)

Tighten the Belt Guard Retaining Screws using a 9/16-wrench.

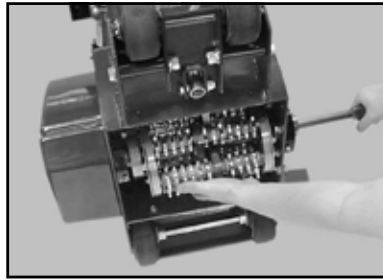

(W)

Install the Cutting Drum; (See Cutting Drum Change-out).

THEORY OF SCARIFYING

The purpose of scarifying is to make scratches, superficial incisions or roughen a surface. There are a number of ways in which a concrete surface can be roughened, the advantage of a scarifying machine is that it allows the user to control the amount of material removed over a large area.

A scarifier can be used to clean, level, roughen, groove, slot, or prepare a concrete surface for coating. The scarifier is able to perform each of these operations by using different types of cutting discs that are setup in different configurations on a cutting drum.









By varying the type of cutting disc and configuration of the cutting drum, a user can:

- Clean a surface of oil, grease, or paint prior to applying a coating or sealer
- Level high spots or misaligned joints
- Remove carpet or tile adhesives as well as paint
- Roughen or create non-slip surfaces
- Slot concrete surfaces for overlays
- Cut safety grooves to minimize slippage

Scarifier cutting discs are either carbide tipped or steel, and are star-shaped in design. Cutting discs may have five or more “points,” and the ends may be round, pointed or blunt depending on application.

Cutting discs designed with carbide inserts tend to be the most commonly used due to their extended life. As the disc is used, more of the carbide insert is exposed until the disc is worn below the bottom of the insert. Once worn below the insert, the disc must be replaced.

ITEM	NUMBER	DESCRIPTION	
1.	158492	Five Point Carbide Tip Cutting Disc Used for grinding, leveling, grooving, cleaning and surface preparation Average Life: 6000 to 8000 Sq Ft	
2.	158493	Six Point Carbide Tip Cutting Disc Used for grinding, leveling, grooving, cleaning and surface preparation Average Life: 8000 to 10000 Sq Ft	
3.	158494	Eighteen Point Sharp Tooth Steel Disc Used for roughening, oil removal, carpet and tile adhesive removal, cleaning and surface preparation Average Life: 500 to 800 Sq Ft	
4.	158495	Twelve Point Blunt Tooth Steel Disc Used for paint and oil removal, traffic and shop floor safety line removal, cleaning and surface preparation Average Life: 500 to 800 Sq Ft	
5.	158575	Hardened Steel Spacer Used to fill empty space between the Cutting Discs	
6.	158520	4" Rear Wheel for MK Scarifiers	
7.	138537	5" Front Wheel for MK Scarifiers	

ORDERING INFORMATION

You may order MK Diamond products through your local MK Diamond distributor or, you may order direct from MK Diamond.

When ordering direct from MK Diamond, please have the following information ready before calling:

- The Model Number of the saw
- The Serial Number of the saw
- Where the saw was purchased and when
- The Part Number for the part(s) being ordered
- The Part Description for the part(s) being ordered

NOTE: Standard orders are \$50.00 or more when ordering direct from MK Diamond. A \$6.00 charge will be added to orders having a net billing value under \$50.00. A nominal handling fee of \$5.00 may apply to some orders.

All parts may be ordered by calling toll free to – 800 421-5830 or 310 539-5221 and asking for Customer Service. For technical questions, call – 800 474-5594.

RETURN MATERIALS POLICY

To expedite the service relative to the return of a product purchased through MK Diamond, please observe the following:

NOTE: When returning all items, they must have been purchased within the previous twelve (12) months.

- Have the Model Number of the saw
- Have the Serial Number of the saw
- Have the location of where the saw was purchased
- Have the date when the saw was purchased
- Contact Customer Service for approval to return the item(s)
- Obtain a Returned Goods Number (RGA) authorizing the return
- Follow the packaging instructions in the following section
- Ensure the RGA number is on the outside of the returned package
- Ensure your item(s) are prepaid to the destination

For returned items, call toll free to – 800 421-5830 or 310 539-5221 and ask for Customer Service.

PACKAGING INSTRUCTIONS

- Remove the Cutting Head and Support Angle Assembly
- Dry the saw before shipping
- When packing, include the following: Saw, Diamond Blade, Blade Guard and Support Angle Assembly and Adjustable Cutting Guide (Other Accessories are not required)
- Package the unit in its original container or one of comparable size (do not ship the unit partially exposed)
- Ensure all parts are secured in the packaging to prevent moving

AUTHORIZED SERVICE CENTERS

For quicker repair time, you may contact MK Diamond Customer Service, toll free, at 800 421-5830 or 310 539-5221 for the Authorized Service Center closest to you or visit our web site at www.mkdiamond.com. For technical questions, call – 800 474-5594.

CONTACT:

Please contact MK Diamond Products, Inc. Customer Service Department with any questions you might have regarding distributors, parts or service.

Telephone: **(800) 421-5830**

Fax: **(310) 539-5158**

E-mail: **Customer_Service@MKDiamond.com**

Customer Service Hours: **Monday through Friday, 6AM-4PM PST**

MK Diamond Products, Inc.

1315 Storm Parkway

Torrance, CA 90501

MK DIAMOND PRODUCTS, INC. LIMITED WARRANTY

MK DIAMOND PRODUCTS, INC. will guarantee every machine they build, to be free from defects in material and workmanship for (1) one year from date of purchase. The obligation of MK DIAMOND PRODUCTS, INC. under this warranty is limited to the repair or replacement of any parts which, under normal use, prove to be defective in material or workmanship. The parts involved or the unit in question should be returned to MK DIAMOND PRODUCTS, INC. or to a point designated by us, transportation prepaid.

This warranty does not obligate us to bear the cost of labor or transportation charges in connection with replacement or repair of defective parts. Likewise, it shall NOT apply to any unit which has been subjected to misuse, neglect or accident. This warranty does NOT apply to any machine which has been repaired or altered outside our factory.

This warranty does NOT obligate MK DIAMOND PRODUCTS, INC., with respect to items not of our manufacture, such as engines, motors, hydraulics, etc., which are subject to their own guarantees and warranties.

We shall in no event be liable for consequential damages or contingent liabilities arising out of failure of any equipment or parts to operate properly.

© COPYRIGHT 2016, MK DIAMOND PRODUCTS, INC. ALL RIGHTS RESERVED.

The MK Diamond logo is a registered trademark of MK Diamond Products, Inc. and may not be used, reproduced, or altered without written permission. All other trademarks are the property of their respective owners and used with permission.

MK Diamond may have patents, patent applications, trade marks, copyrights of other intellectual property right covering this product in this document.

This manual MUST accompany the equipment at all times. This manual is considered a permanent part of the equipment and should remain with the unit if resold.

The information and specifications included in this publication were in effect at the time of approval for printing.

MK-SCARIFIER
OWNER'S MANUAL
& OPERATING INSTRUCTIONS



MK Diamond Products, Inc.

MK Diamond Products, Inc.
1315 Storm Parkway
Torrance, CA 90501

Toll-Free: (800) 421-5830
Phone: (310) 539-5221
Fax: (310) 539-5158
www.mkdiamond.com