

**MK DIAMOND CX-3, WITH
GX160 HONDA ENGINE
WALK-BEHIND CONCRETE SAW
PARTS LIST & EXPLODED VIEWS**

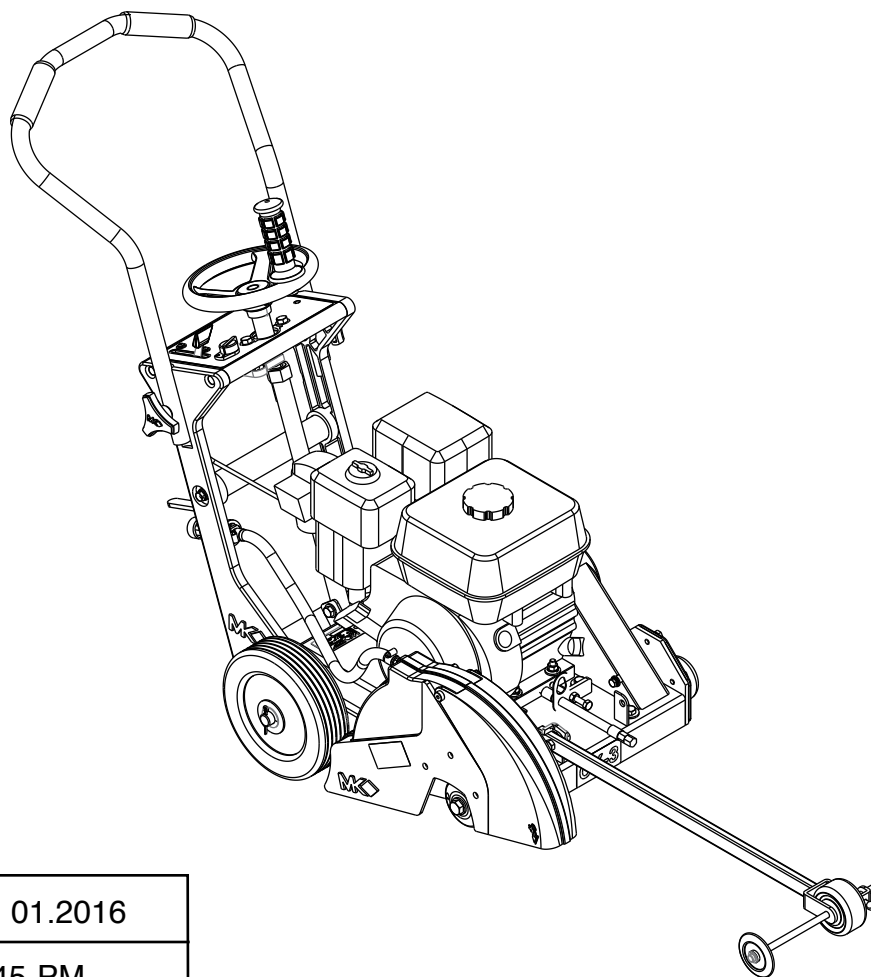

Revision 207	01.2016
Manual 159345-PM	

Caution: Read all safety and operating instructions before using this equipment. This parts list **MUST** accompany the equipment at all times.

NOTES

TABLE OF CONTENTS

MK DIAMOND CX-3 WITH GX160 HONDA ENGINE

PAGE

INTRODUCTION

Welcome	4
Safety Warnings	4

PARTS LIST

FIGURE 1 - PARTS LIST: MK-CX3 CONC SAW W/GX160H - P/N 159345	5
FIGURE 2 - PARTS LIST: MK-CX3 CONC SAW W/GX160H - P/N 159345	6-7
FIGURE 3 - PARTS LIST: MK-CX3 CONC SAW W/GX160H - P/N 159345	8-9
FIGURE 4 - PARTS LIST: MK-CX3 LESS ENGINE - P/N 165974	10-11
FIGURE 5 - PARTS LIST: MK-CX3 LESS ENGINE - P/N 165974	12-13
FIGURE 6 - PARTS LIST: MK-CX3 LESS ENGINE - P/N 165974	14-15
FIGURE 7 - PARTS LIST: ASSY, FRONT AXLE - P/N 165975	16
FIGURE 8 - PARTS LIST: ASSY, BLADE SHAFT - P/N 165977	17

GENERAL PRODUCT INFORMATION

Accessories, Ordering and Return Information	18
Contact Information and Limited Warranty	19

INTRODUCTION

Congratulations on your purchase of a Home Depot CX-3 Concrete Saw. We are certain that you will be pleased with your purchase. MK Diamond takes pride in producing the finest construction power tools and diamond blades in the industry.

Operated correctly, your CX-3 should provide you with years of service. In order to help you, we have included this parts manual. This manual contains exploded views and parts lists for your CX-3. Please take a few minutes to familiarize yourself with the components by reading and reviewing this manual.

If you should have questions, please feel free to call our friendly customer service department at: **(800) 421-5830**.

Regards,

MK Diamond

WARNINGS

Each machine is supplied with an operating instruction manual. Follow instructions strictly to ensure long service in normal operation. For repairs and service parts, contact your authorized MK Diamond dealer.



WARNING

Failure to comply with these warnings and instructions could result in death or serious injury.



WARNING

Always park the machine on a level surface with the engine "OFF" and the ignition switch set in the "OFF" position before performing any maintenance. **Let the machine cool down! Disconnect spark-plug!**



WARNING

This saw was designed for certain applications only. **DO NOT** modify this saw or use for any application other than for which it was designed. If you have any questions relative to its application, **DO NOT** use the saw until you have contacted your MK Diamond dealer. The manufacturer accepts no responsibility by unsuitable use or modifications.

FIGURE 1 - PARTS LIST: MK-CX3 CONC SAW W/GX160H - P/N 159345

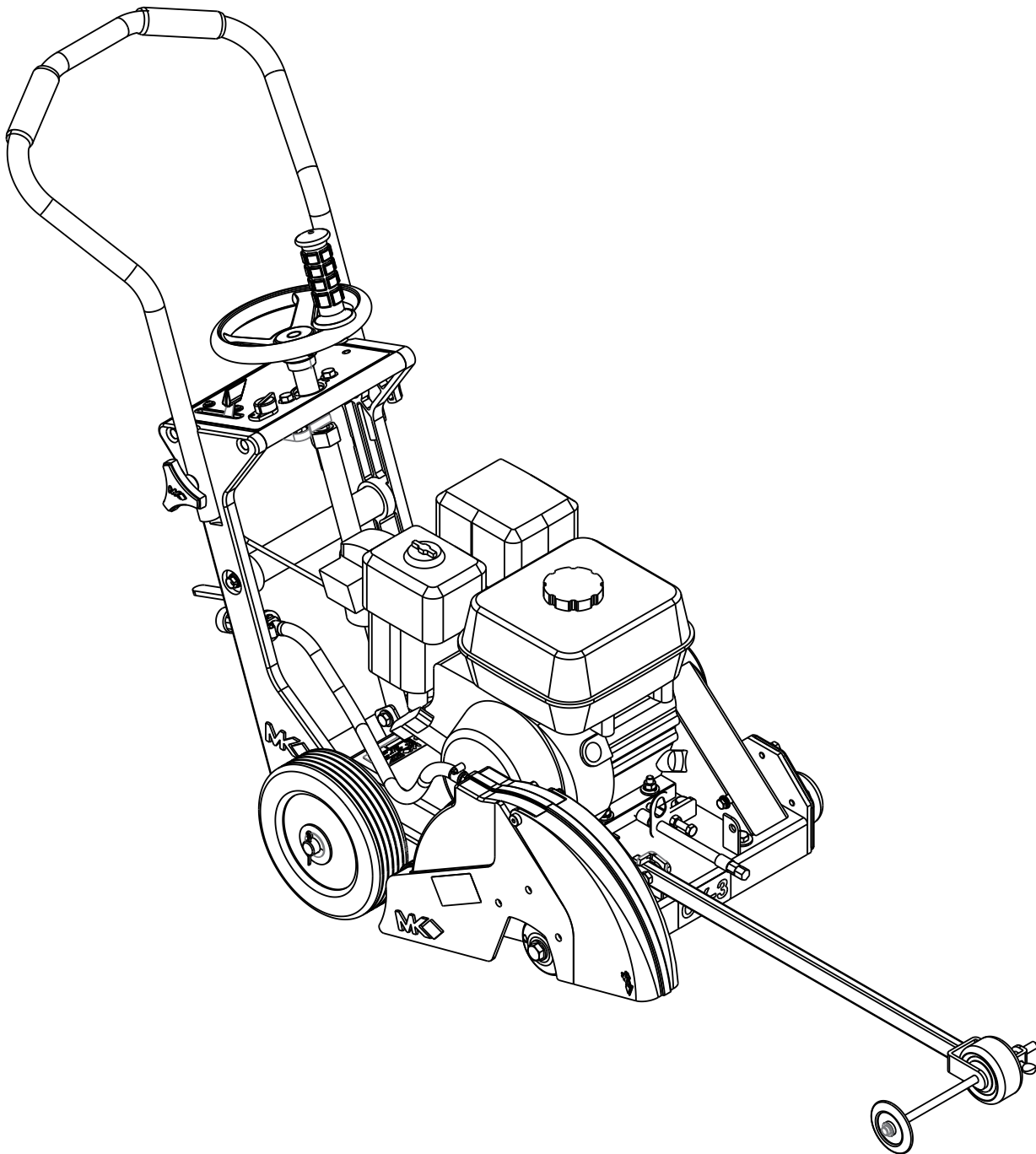

FIGURE 2 - PARTS LIST: MK-CX3 CONC SAW W/GX160H - P/N 159345

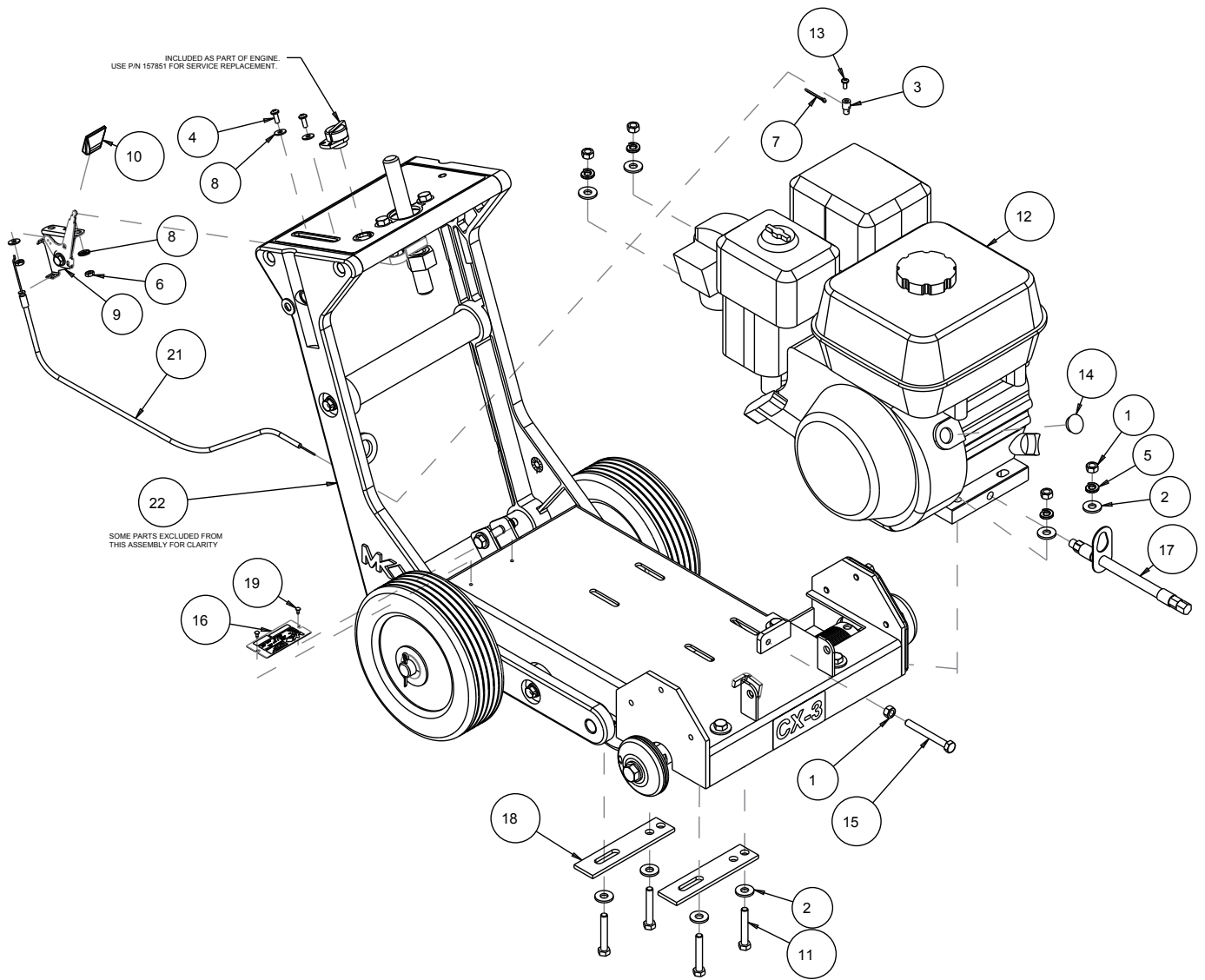

FIGURE 2 - PARTS LIST: MK-CX3 CONC SAW W/GX160H - P/N 159345

ITEM NO.	DESCRIPTION	PART #	QTY.
1	NUT, HEX, 5/16-18	101196	5
2	WASHER, 5/16 FLAT CUT	101352	8
3	PIN, THROTTLE CONTROL	151284	1
4	SCREW, 10-24 X 1/2 PAN HEAD	151744	2
5	WASHER, LOCK, SPLIT, 5/16	151747	4
6	NUT, HEX, 10 -24	151749	2
7	PIN, 1/16 X 3/4 COTTER	152518	1
8	WASHER, #10 SAE FLAT	154369	4
9	HEAD, THROTTLE CONTROL	155406-1	1
10	KNOB, THROTTLE PADDLE	155406-2	1
11	SCREW, 5/16-18 X 2 HEX HEAD	155494	4
12	ENGINE, HONDA GX160 W/CYC	156282	1
13	SCREW, 8-32 X 3/8 PAN HEAD PHILLIPS	156614	1
14	PLUG, HOLE PLASTIC 3/4"	156615	1
15	BOLT, 5/16/-18 X 2-3/4 HEX HEAD TAP	156974	1
16	TAG, SERIAL #, BLANK	157500	1
17	ASSY, OIL DRAIN, 10MM	157577-01	1
18	PLATE, ENGINE BOLT	157847	2
19	DRIVE SCREW, #7 X 5/16 ROUND HEAD	157849	2
20	WIRE HARNESS, CX3	158232	1
21	CABLE, THROTTLE, HONDA	159479	1
22	MK-CX3 LESS ENGINE	165974	1

FIGURE 3 - PARTS LIST: MK-CX3 CONC SAW W/GX160H - P/N 159345

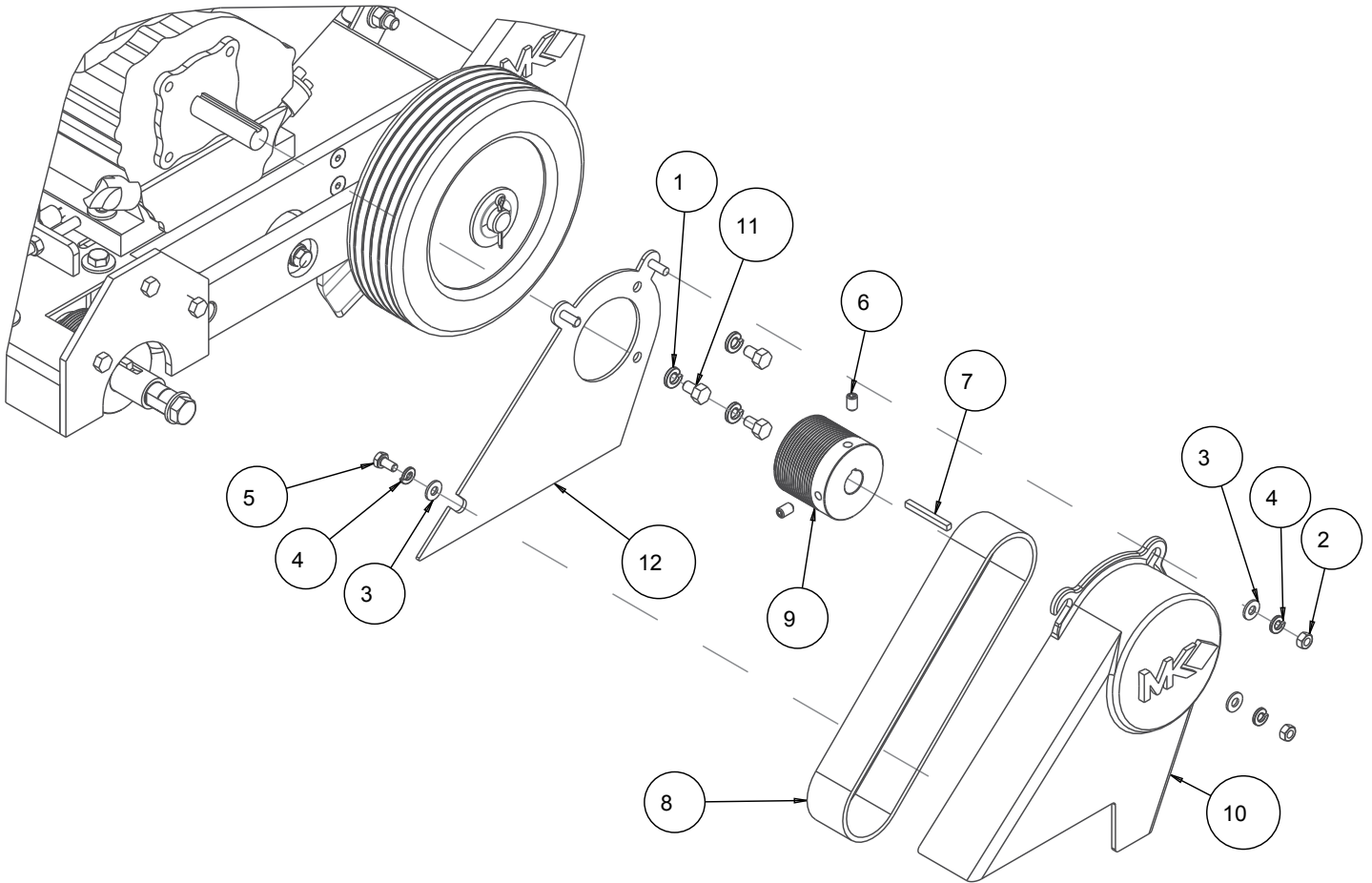

FIGURE 3 - PARTS LIST: MK-CX3 CONC SAW W/GX160H - P/N 159345

ITEM NO.	DESCRIPTION	PART #	QTY.
1	WASHER, 5/16 SPLIT LOCK	151747	3
2	NUT, 1/4-20 HEX	151893	2
3	WASHER, 1/4 SAE FLAT	151915	3
4	WASHER, 1/4 SPLIT LOCK	152591	3
5	SCREW, 1/4-20 X 1/2 HEX HEAD	152608	1
6	SCREW, 1/4-20 X 1/2 SOCKET HEAD SET	157084	2
7	KEY, 3/16 X 3/16 X 1-3/4	157561	1
8	BELT, MICRO-V, 240J16	158824	1
9	PULLEY, 16J25 X .75 BORE	158959	1
10	CASTING, BELT GUARD, CX-3 COMP	159021	1
11	SCREW, 5/16-24 X 1/2 HEX HEAD MACHINE	159205	3
12	GUARD, INNER BELT	159250	1

FIGURE 4 - PARTS LIST: MK-CX3 LESS ENGINE - P/N 165974

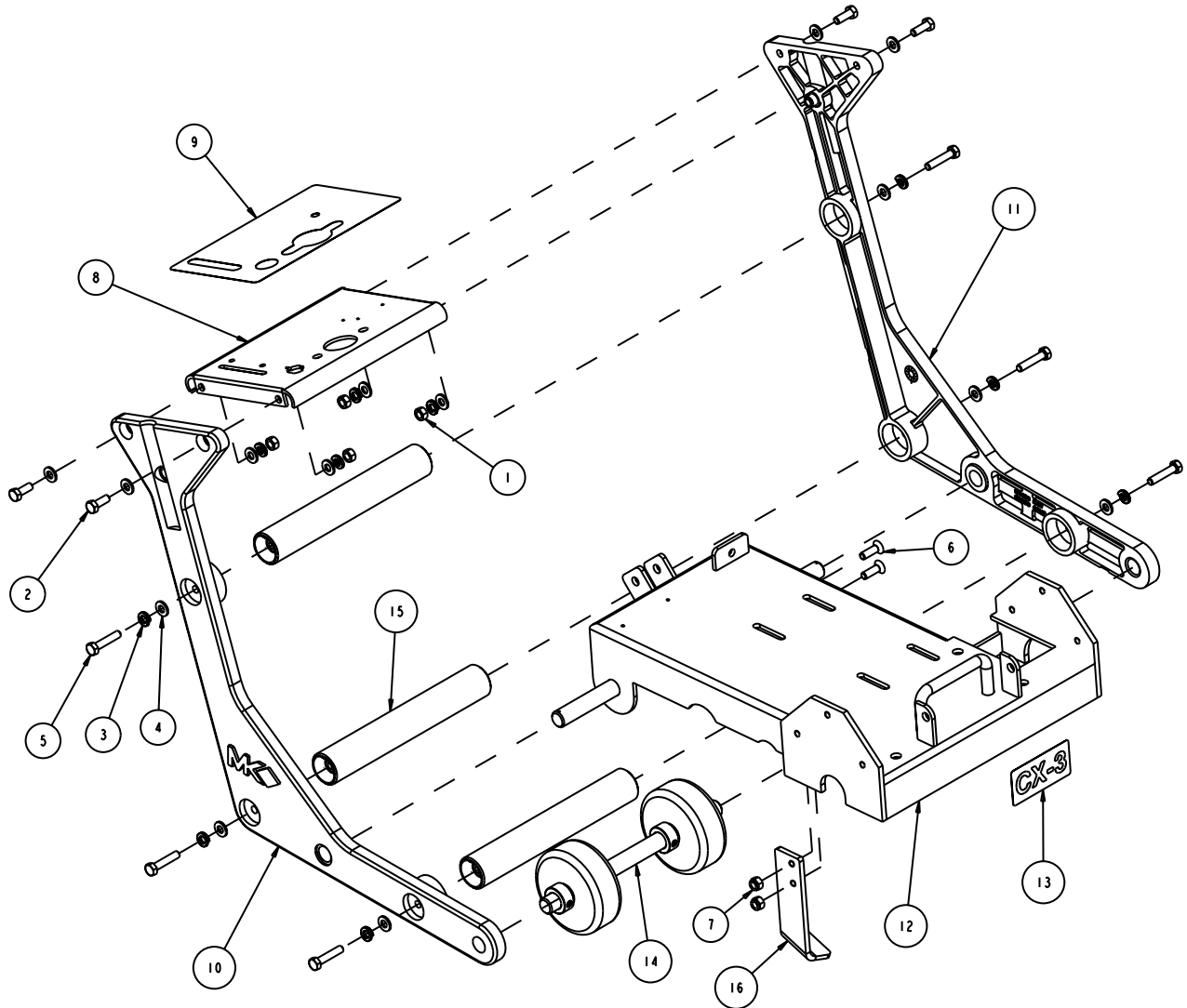

FIGURE 5 - PARTS LIST: MK-CX3 LESS ENGINE - P/N 165974

ITEM NO.	DESCRIPTION	PART #	QTY.
1	NUT, 5/16-18 HEX	101196	4
2	SCREW, 5/16-18 X 1 HEX HEAD MACHINE	151743	4
3	WASHER, 5/16 SPLIT LOCK	151747	10
4	WASHER, 5/16 SAE FLAT	151754	14
5	SCREW, 5/16-18 X 1-1/2 HEX HEAD MACHINE	152467	6
6	SCREW, 5/16-18 X 1.0 FLAT HEAD SOCKET	155552	2
7	NUT, 5/16-18 NYLOK HEX	158289	2
8	CONSOLE, FRAME	158828	1
9	LABEL, CONSOLE, CX3	159208	1
10	CASTING, FRAME, RIGHT CX3-COMP	159257	1
11	CASTING, FRAME, LEFT CX3-COMP	159259	1
12	TRUCK, CX3	159260	1
13	LABEL, CX3	159482	1
14	ASSY, FRONT AXLE	165975	1
15	ASSY, FRAME SUPPORT	165978	3
16	BRACKET, UP STOP	165998	1

FIGURE 5 - PARTS LIST: MK-CX3 LESS ENGINE - P/N 165974

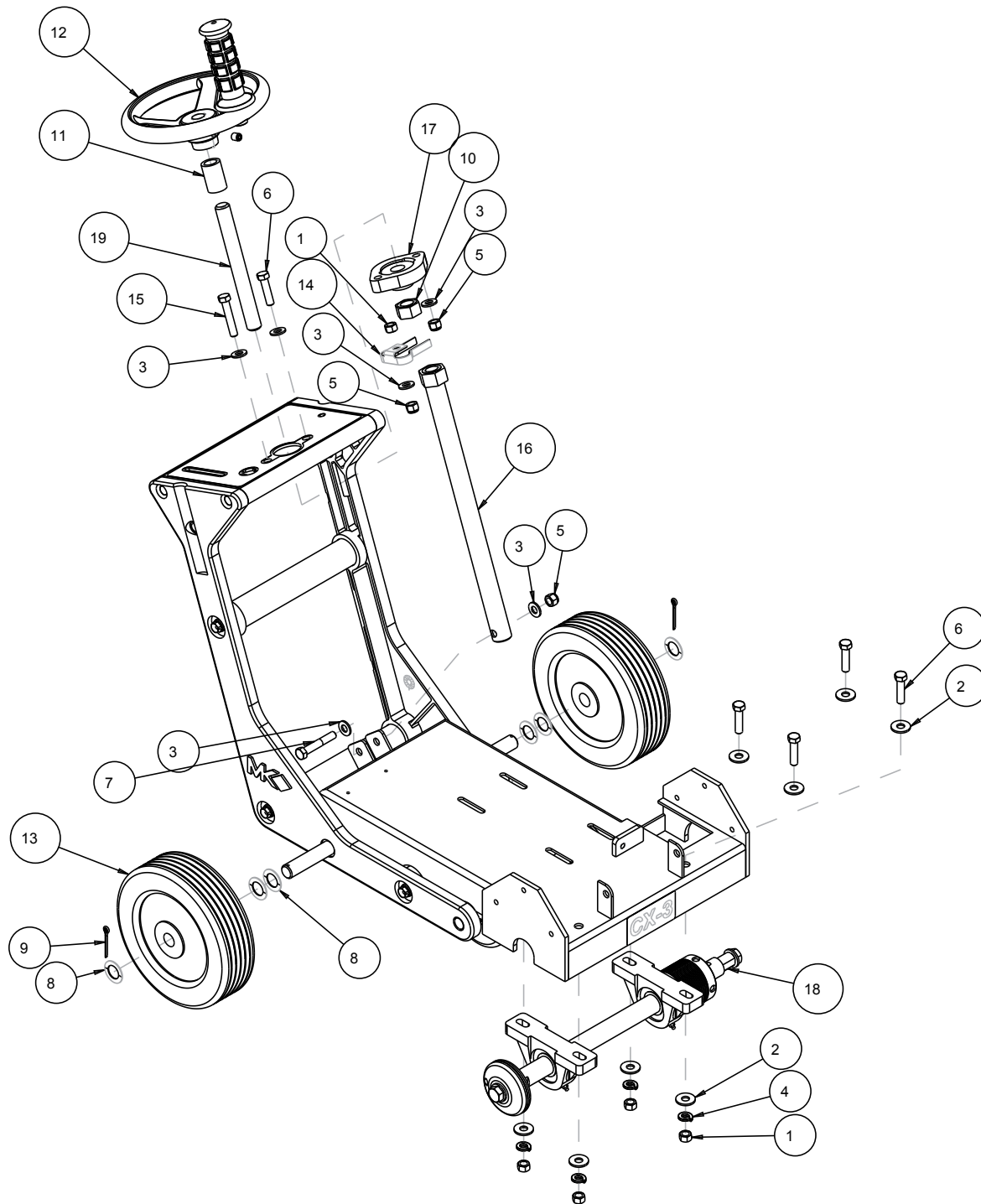

FIGURE 5 - PARTS LIST: MK-CX3 LESS ENGINE - P/N 165974

ITEM NO.	DESCRIPTION	PART #	QTY.
1	NUT, 3/8-16 HEX	101188	5
2	WASHER, FLAT CUT 3/8	101360	8
3	WASHER, 3/8 SAE FLAT	150923	6
4	WASHER, 3/8 SPLIT LOCK	150925	4
5	NUT, 3/8-16 NYLOK HEX	152505	3
6	SCREW, 3/8-16 X 1-1/2 HEX HEAD	153528	5
7	SCREW, 3/8-16 X 2-1/4 HEX HEAD	153529	1
8	SHIM, .045 THK .750 ID 1.250 OD	153699	6
9	PIN, COTTER 1/8 X 1 1/2	153861	2
10	NUT, 3/4-10 HEX	155063	1
11	SPACER, DEPTH CONTROL	155161	1
12	ASSY, CRANK WHEEL, 3/4-10	155457	1
13	WHEEL, REAR 8"	155986	2
14	SPRING, DETENT	156609	1
15	SCREW, 3/8-16 X 2 HEX HEAD	156829	1
16	TUBE, DEPTH CTRL, 3/4-10	165970	1
17	BEARING, FLANGE, 3/4ID, FD204	165971	1
18	ASSY, BLADE SHAFT	165977	1
19	STUD, 3/4-10 X 7"	167980	1

FIGURE 6 - PARTS LIST: MK-CX3 LESS ENGINE - P/N 165974

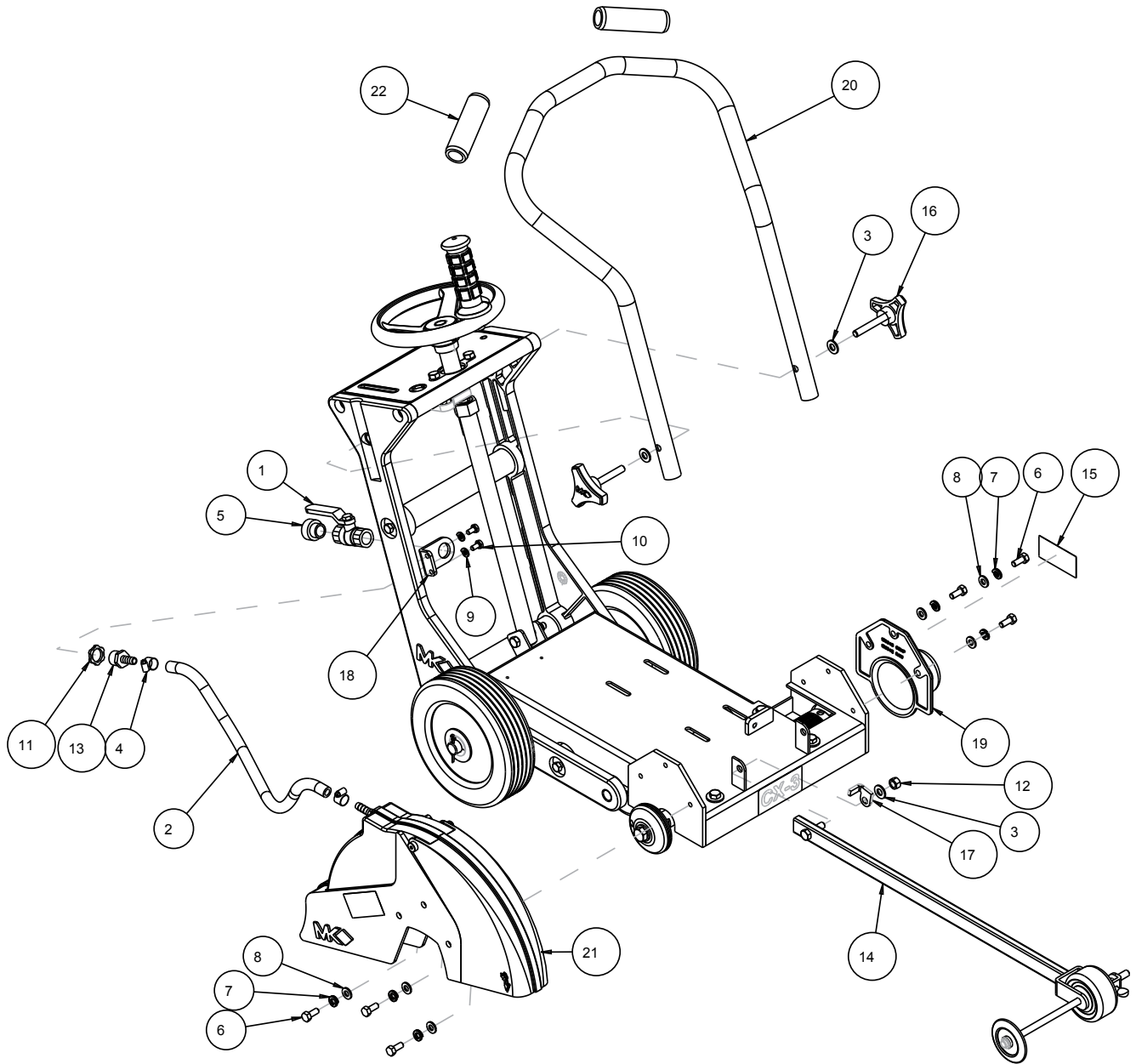
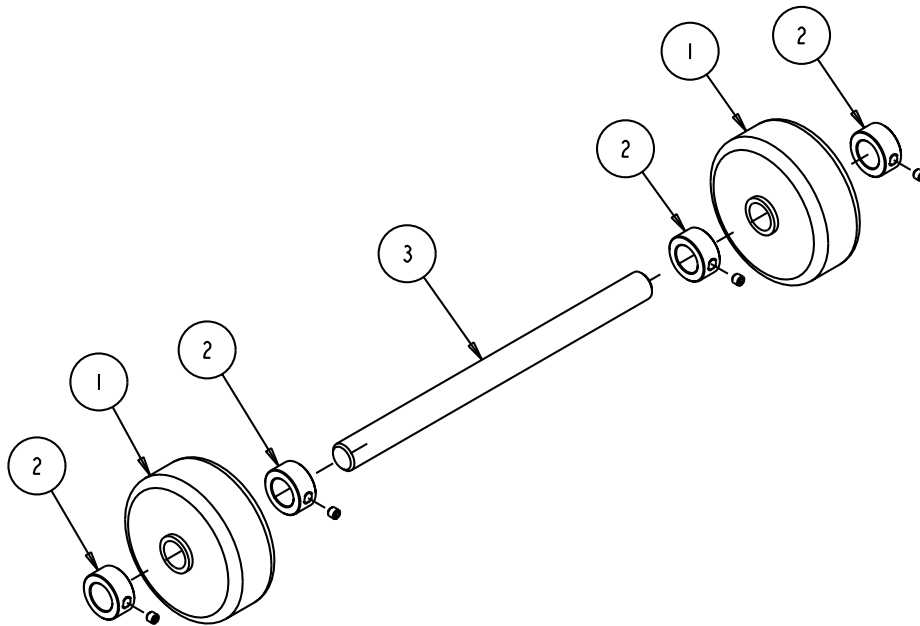

FIGURE 6 - PARTS LIST: MK-CX3 LESS ENGINE - P/N 165974

ITEM NO.	DESCRIPTION	PART #	QTY.
1	VALVE, BALL 1/2"	150843	1
2	HOSE, 3/8 X 5/8 VINYL, 30"	150845	1
3	WASHER, 3/8 SAE FLAT	150923	3
4	CLAMP, 5/8 HOSE	151198	2
5	FITTING, 1/2 MNPT X 3/4 FNH	151322	1
6	SCREW, 5/16-18 X 3/4 HEX HEAD	151369	6
7	WASHER, LOCK, SPLIT, 5/16	151747	6
8	WASHER, 5/16 SAE FLAT	151754	6
9	WASHER, 1/4 SPLIT LOCK	152591	2
10	SCREW, 1/4-20 X 1/2 HEX HEAD	152608	2
11	NUT, LOCK STEEL 1/2" NPT	152729	1
12	NUT, 3/8-16 HEX CENTERLOCK	153522	1
13	FITTING, 1/2 MNPT X 3/8 BARB	153653	1
14	ASSY, POINTER ARM	155568	1
15	LABEL, CAUTION, GUARDS IN PLACE	155587	1
16	KNOB, TRI PLASTIC MK-770 2 - 1/4	156770-04	2
17	CLIP, STOP	157837	1
18	BRACKET, WATER VALVE	158833	1
19	GUARD, SHAFT (COMP)	158843	1
20	HANDLEBAR	158849	1
21	ASSY, 14" BLADEGUARD	165976	1
22	GRIP, HANDLE	229413	2

FIGURE 7 - PARTS LIST: ASSY, FRONT AXLE - P/N 165975



ITEM NO.	DESCRIPTION	PART #	QTY.
1	WHEEL, FRONT, 04 X 1-1/2W	150830	2
2	COLLAR, SET, 3/4"	153814	4
3	AXLE, FRONT	158862	1

FIGURE 8 - PARTS LIST: ASSY, BLADE SHAFT - P/N 165977

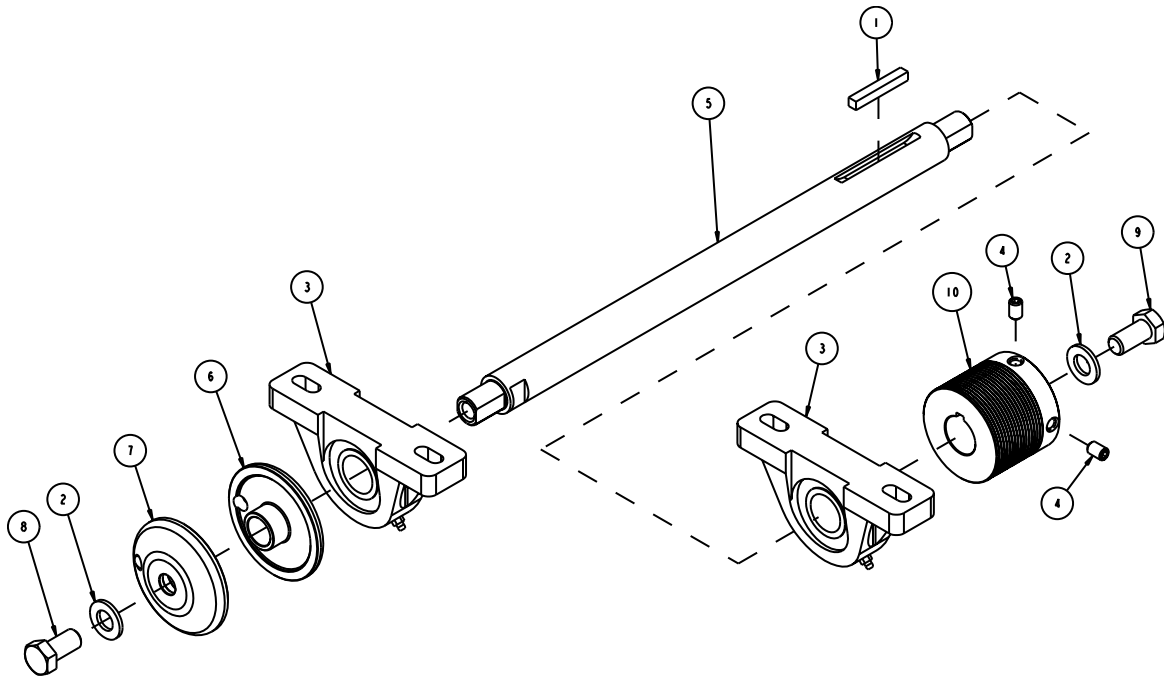

ITEM NO.	DESCRIPTION	PART OR IDENTIFYING NO.	QTY. REQ.
1	KEY, SQUARE, 1/4 X 1-3/4	150796	1
2	WASHER, 1/2 SAE FLAT	150924	2
3	BEARING, PILLOW BLK 1"	155072	2
4	SCREW, 5/16-18 X 3/8 SOCKET HEAD SET	157084	2
5	SHAFT, BLADE	158879	1
6	FLANGE, INNER	158880	1
7	ASSY, FLANGE, OUTER	158881	1
8	SCREW, 1/2-13 X 1 HEX HEAD CAP, LH	159203	1
9	SCREW, 1/2-13 X 1 HEX HEAD CAP	159204	1
10	PULLEY, 16J25 X 1.0 BORE	158470	1

ORDERING INFORMATION

You may order MK Diamond products through your local MK Diamond distributor or, you may order direct from MK Diamond.

When ordering direct from MK Diamond, please have the following information ready before calling:

- The Model Number of the saw
- The Serial Number of the saw
- Where the saw was purchased and when
- The Part Number for the part(s) being ordered
- The Part Description for the part(s) being ordered

NOTE: There is a \$25.00 minimum order when ordering direct from MK Diamond. A \$5.00 charge will be added to orders having a net billing value under \$50.00. All purchases must be made using VISA, MasterCard or American Express.

All parts may be ordered by calling toll free to – 800 421-5830 or 310 539-5221 and asking for Customer Service. For technical questions, call – 800 474-5594.

RETURN MATERIALS POLICY

To expedite the service relative to the return of a product purchased through MK Diamond, please observe the following:

NOTE: When returning all items, they must have been purchased within the previous twelve (12) months.

- Have the Model Number of the saw
- Have the Serial Number of the saw
- Have the location of where the saw was purchased
- Have the date when the saw was purchased
- Contact Customer Service for approval to return the item(s)
- Obtain a Returned Goods Number (RGA) authorizing the return
- Follow the packaging instructions in the following section
- Ensure your item(s) are prepaid to the destination

For returned items, call toll free to – 800 421-5830 or 310 539-5221 and ask for Customer Service. For technical questions, call – 800 474-5594 or 310 257-2845.

PACKAGING INSTRUCTIONS

- Remove the Cutting Head and Support Angle Assembly
- Dry the saw before shipping
- When packing, include the following: Saw, Diamond Blade, Blade Guard and Support Angle Assembly and Adjustable Cutting Guide (Other Accessories are not required)
- Package the unit in its original container or one of comparable size (do not ship the unit partially exposed)
- Ensure all parts are secured in the packaging to prevent moving

AUTHORIZED SERVICE CENTERS

For quicker repair time, you may contact MK Diamond Customer Service, toll free, at 800 421-5830 or 310 539-5221 for the Authorized Service Center closest to you or visit our web site at www.mkdiamond.com. For technical questions, call – 800 474-5594.

CONTACT

Please contact MK Diamond Products, Inc. Customer Service Department with any questions you might have regarding distributors, parts or service.

Telephone: **(800) 421-5830**

Fax: **(310) 539-5158**

E-mail: **Customer_Service@MKDiamond.com**

Customer Service Hours: **Monday through Friday, 6AM-4PM PST**

MK Diamond Products, Inc.

1315 Storm Parkway

Torrance, CA 90501

MK DIAMOND PRODUCTS, INC. LIMITED WARRANTY

MK DIAMOND PRODUCTS, INC. will guarantee every machine they build, to be free from defects in material and workmanship for (1) one year from date of purchase. The obligation of MK DIAMOND PRODUCTS, INC. under this warranty is limited to the repair or replacement of any parts which, under normal use, prove to be defective in material or workmanship. The parts involved or the unit in question should be returned to MK DIAMOND PRODUCTS, INC. or to a point designated by us, transportation prepaid.

This warranty does not obligate us to bear the cost of labor or transportation charges in connection with replacement or repair of defective parts. Likewise, it shall NOT apply to any unit which has been subjected to misuse, neglect or accident. This warranty does NOT apply to any machine which has been repaired or altered outside our factory.

This warranty does NOT obligate MK DIAMOND PRODUCTS, INC., with respect to items not of our manufacture, such as engines, motors, hydraulics, etc., which are subject to their own guarantees and warranties.

We shall in no event be liable for consequential damages or contingent liabilities arising out of failure of any equipment or parts to operate properly.

© COPYRIGHT 2013, MK DIAMOND PRODUCTS, INC. ALL RIGHTS RESERVED.

The MK Diamond logo is a registered trademark of MK Diamond Products, Inc. and may not be used, reproduced, or altered without written permission. All other trademarks are the property of their respective owners and used with permission.

MK Diamond may have patents, patent applications, trade marks, copyrights of other intellectual property right covering this product in this document.

This manual MUST accompany the equipment at all times. This manual is considered a permanent part of the equipment and should remain with the unit if resold.

The information and specifications included in this publication were in effect at the time of approval for printing.

**MK DIAMOND CX-3, WITH GX160 HONDA ENGINE
PARTS LIST & EXPLODED VIEWS**



MK Diamond Products, Inc.

MK Diamond Products, Inc.
1315 Storm Parkway
Torrance, CA 90501

Toll-Free: (800) 845-3729
Phone: (310) 539-2221
Fax: (310) 539-5158
www.mkdiamond.com