

BX-4

BRICK SAW WITH OR WITHOUT MISTING DUST CONTROL

OWNER'S MANUAL & OPERATING INSTRUCTIONS

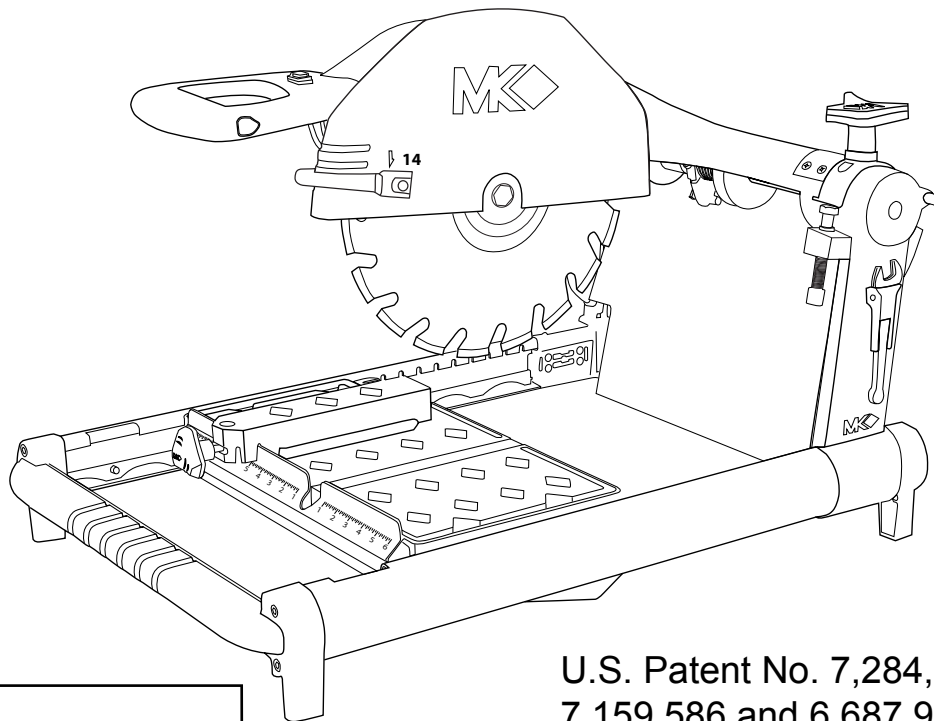

U.S. Patent No. 7,284,547,
7,159,586 and 6,687,972

| | |
|--------------|---------|
| | |
| Revision 112 | 04.2015 |

Enter the Serial Number of your new saw in the space below.
The Serial Number is located on the left side of the blade guard.

SERIAL NUMBER:

| |
|--|
| |
|--|

CAUTION:

Read all safety and operating instructions
before using this equipment



NOTE:

For your (1) one year warranty to be effective, complete the warranty card
(including the Serial Number) and mail it in as soon as possible.

NOTES

TABLE OF CONTENTS & INTRODUCTION

| TABLE OF CONTENTS | PAGE NO. | INTRODUCTION |
|---|----------|---|
| SAFETY: | | |
| Safety Messages | 4 | We at MK Diamond want to congratulate you on selecting the BX-4 Brick Saw. We are certain that you will be pleased with your purchase. MK Diamond takes pride in producing the finest products in the industry. |
| Electrical Requirements and Grounding Instructions | 7 | |
| Safety Label Locations & Symbols | 9 | |
| Product Specifications | 10 | |
| UNPACKING AND ASSEMBLY: | | |
| Unpacking | 11 | Operated correctly, your BX-4 should provide you with years of quality service. This owners manual contains information necessary to operate and maintain your BX-4 safely and correctly. Please take a few minutes to familiarize yourself with the BX-4 by reading and reviewing this manual. |
| Contents | 11 | |
| Transport | 12 | |
| Assembly | 12 | |
| SETUP, ADJUSTMENT AND OPERATION: | | |
| Setup | 14 | If you should have questions concerning your BX-4, please feel free to call our friendly customer service department at: (800) 421-5830. |
| Adjustment and Operation | 17 | |
| Cleanup | 23 | |
| MAINTENANCE AND TROUBLESHOOTING: | | |
| Maintenance | 24 | |
| Troubleshooting | 30 | |
| Wiring Diagram | 37 | |
| EXPLODED VIEW AND PARTS LIST: | | |
| Exploded View BX-4 | 38 | |
| Replacement Parts List | 39 | |
| Misting System Parts List | 45 | |
| THEORY: | | |
| Theory of Diamond Blades | 47 | |
| ACCESSORIES, ORDERING and RETURN INSTRUCTIONS: | | |
| Accessories | 48 | |
| Ordering Information | 48 | |
| Return Material Policy | 49 | |
| Packaging Instructions | 49 | |
| Authorized Service Centers | 49 | |

SAFETY

Read and follow all safety, operating and maintenance instructions. Failure to read and follow these instructions could result in injury or death to you or others. Failure to read and follow these instructions could also result in damage and/or reduced equipment life.

SAFETY MESSAGES:

Safety messages inform the user about potential hazards that could lead to injury, death and/or equipment damage. Each safety message will be preceded by one of the following (3) three words that identify the severity of the message.

⚠ DANGER

Not following instructions **WILL** lead to **DEATH** or **SERIOUS INJURY**

⚠ WARNING

Not following instructions **COULD** lead to **DEATH** or **SERIOUS INJURY**

⚠ CAUTION

Not following instructions **CAN** lead to injury

DAMAGE PREVENTION AND INFORMATION MESSAGES:

A Damage Prevention Message is to inform the user of important information and/or instructions that could lead to equipment or other property damage if not followed. Information Messages convey information that pertains to the equipment being used. Each message will be preceded by the word NOTE, as in the example below.

NOTE:

Equipment and/or property damage may result if these instructions are not followed.

GENERAL SAFETY PRECAUTIONS AND HAZARD SYMBOLS:

In order to prevent injury, the following safety precautions and symbols should be followed at all times!

Safety Precautions:

KEEP GUARDS IN PLACE.



In order to prevent injury, keep guards in place and in working order at all times.

REMOVE ADJUSTING KEYS AND WRENCHES.

Form a habit of checking to see that keys and adjusting wrenches are removed from the power tool before it is turned on.

KEEP WORK AREA CLEAN.

Cluttered work areas and benches invite accidents.

DO NOT USE IN DANGEROUS ENVIRONMENTS.

Do not use power tools in damp or wet locations nor expose them to rain. Always keep the work area well lighted.

KEEP CHILDREN AWAY.

All visitors and children should be kept a safe distance from work area.

MAKE THE WORKSHOP KID PROOF.

Make the workshops kid proof by using padlocks, master switches or by removing starter keys.

DO NOT FORCE THE TOOL.

A power tool will do a job better and safer operating at the rate for which it was designed.

USE THE RIGHT TOOL.

Do not force a tool or an attachment, to do a job that it was not designed to do.

SAFETY

USE THE PROPER EXTENSION CORD.

If using an extension cord make sure it is in good condition first. When using an extension cord, be sure to use one heavy enough to carry the current your product will draw. An undersized cord will cause a drop in line voltage that will result in a loss of power and overheating. TABLE 1, Page 8 shows the correct AWG size to use depending on cord length and nameplate ampere rating. If in doubt, use the next heavier gage. The smaller the gage number, the heavier the cord.

WEAR PROPER APPAREL.

Do not wear loose clothing, gloves, neckties, rings, bracelets, or other jewelry that may be caught in moving parts. Non-slip footwear is recommended. Wear protective hair covering to contain long hair.

ALWAYS USE SAFETY GLASSES.



Safety glasses should always be worn when working around power tools. In addition, a face, dust mask or respirator should be worn if a cutting operation is dusty. Everyday eyeglasses only have impact resistant lenses and may not prevent eye injury—they are NOT safety glasses.

SECURE WORK.

Clamps or a vise should be used to hold work whenever practical. Keeping your hands free to operate a power tool is safer.

DO NOT OVERREACH.

Keep proper footing and balance at all times by not overreaching.

MAINTAIN TOOLS WITH CARE.

Keep tools clean for the best and safest performance. Always follow maintenance instructions for lubricating, and when changing accessories.

DISCONNECT TOOLS.

Power tools should always be disconnected before servicing or when changing accessories, such as blades, bits, cutters, and the like.

REDUCE THE RISK OF UNINTENTIONAL STARTING.



Make sure the trigger switch; locking button is in the RELEASE position before plugging in a power tool.

USE RECOMMENDED ACCESSORIES.

Consult the owner's manual for recommended accessories. Using improper accessories may increase the risk of personal or by-stander injury.

NEVER STAND ON THE TOOL.

Serious injury could occur if a power tool is tipped, or if a cutting tool is unintentionally contacted.

CHECK FOR DAMAGED PARTS.

Before using a power tool, check for damaged parts. A guard or any other part that is damaged should be carefully checked to determine it would operate properly and perform its intended function. Always check moving parts for proper alignment or binding. Check for broken parts and mountings and all other conditions that may affect the operation of the power tool. A guard, or any damaged part, should be properly repaired or replaced.

DIRECTION OF FEED.

Always feed work into a blade or cutter against the direction of rotation. A blade or cutter should always be installed such that rotation is in the direction of the arrow imprinted on the side of the blade or cutter.

NEVER LEAVE A TOOL RUNNING UNATTENDED – TURN POWER OFF.

Do not leave a tool until it comes to a complete stop. Always turn a power tool OFF when leaving the work area, or, when a cut is finished.

SAFETY

Hazard Symbols:

ELECTRICAL SHOCK!

 Never touch electrical wires or components while the motor is running. Exposed, frayed or worn electrical motor wiring can be sources of electrical shock that could cause severe injury or burns.

ACCIDENTAL STARTS!

 Before plugging the equipment into an electrical outlet, be sure the trigger switch, locking button is in the "RELEASE" position to prevent accidental starting. Unplug the power tool before performing any service operation.

ROTATING OR MOVING PARTS!

 Keep hands, feet, hair, and clothing away from all moving parts to prevent injury. Never operate a power tool with covers, shrouds, or guards removed.

⚠ WARNING

Sawing and drilling generates dust. Excessive airborne particles may cause irritation to eyes, skin and respiratory tract. To avoid breathing impairment, always employ dust controls and protection suitable to the material being sawed or drilled; See OSHA (29 CFR Part 1910.1200). Diamond Blades improperly used are dangerous. Comply with American National Standards Institute Safety Code, B7.1 and, Occupational Safety and Health Act covering Speed, Safety Guards, Flanges, Mounting Procedures, General Operating Rules, Handling, Storage and General Machine Conditions.

CALIFORNIA PROPOSITION 65 MESSAGE:

⚠ WARNING

Some dust created by power sanding, sawing, grinding, drilling, and other construction activities contain chemicals known [to the State of California] to cause cancer, birth defects or other reproductive harm. Some examples of these chemicals are:

- Lead, from lead-based paints
- Crystalline silica, from bricks and cement and other masonry products and
- Arsenic and chromium, from chemically treated lumber

For further information, consult the following sources:

<http://www.osha.gov/SLTC/silicacrystalline/index.html>

http://www.oehha.org/prop65/out_of_date/6022kLstA.html

Your risk from these exposures varies depending on how often you do this type of work. To reduce your exposure to these chemicals, work in a well-ventilated area, and work with approved safety equipment, such as those dust masks that are specially designed to filter out microscopic particles.

ELECTRICAL REQUIREMENTS & GROUNDING INSTRUCTIONS

In order to prevent potential electrical shock and injury, the following electrical safety precautions and symbols should be followed at all times!

⚠️ WARNING



In case of a malfunction or breakdown, grounding provides a path of least resistance for electric current to reduce the risk of electric shock. This tool is equipped with an electric cord having an equipment-grounding conductor and a grounding plug. The plug must be plugged into a matching outlet that is properly installed and grounded in accordance with all local codes and ordinances.

- Do not modify the plug provided – if it will not fit the outlet; have the proper outlet installed by a qualified electrician
- Improper connections of the equipment-grounding conductor can result in a risk of electric shock. The equipment-grounding conductor is the insulated conductor that has an outer surface that is green, with or without yellow stripes. If repair or replacement of the electric cord or plug is necessary, do not connect the equipment-grounding conductor to a live terminal
- Check with a qualified electrician or service personnel if the grounding instructions are not completely understood, or if in doubt as to whether the tool is properly grounded
- Use only 3-wire extension cords that have 3-prong grounding plugs and 3-pole receptacles that accept the tool's plug
- Repair or replace a damaged or worn cord immediately

⚠️ WARNING



This tool is intended for use on a circuit that has an outlet that looks like the one shown in Sketch A of Figure 1. The tool has a grounding plug that looks like the plug illustrated in Sketch A of FIGURE 1. A temporary adapter, which looks like the adapter illustrated in sketches B and C, may be used to connect this plug to a 2-pole receptacle as shown in Sketch B, if a properly grounded outlet is not available.

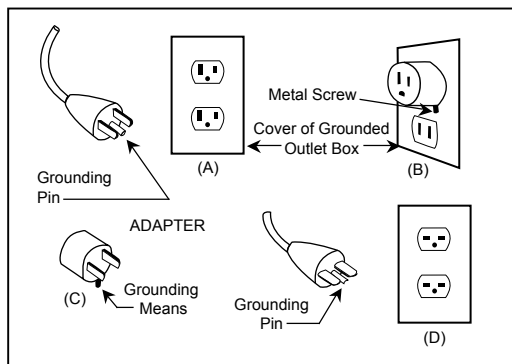

- The temporary adapter should be used only until a properly grounded outlet can be installed by a qualified electrician. The green-colored rigid ear, lug, and the like, extending from the adapter, must be connected to a permanent ground such as a properly grounded outlet box.

NOTE: Use of a temporary adapter is not permitted in Canada.

FIGURE 1

⚠️ WARNING



To reduce the risk of electrocution, keep all connections dry and off the ground.

A Ground Fault Circuit Interrupter (GFCI) should be provided on the circuit(s) or outlet(s) to be used for the Brick Saw. Receptacles are available having built-in GFCI protections and may be used for this measure of safety.

When using an extension cord, the GFCI should be installed closest to the power source, followed by the extension cord and lastly, the saw.

ELECTRICAL REQUIREMENTS & GROUNDING INSTRUCTIONS

⚠ WARNING



To avoid the possibility of the appliance plug or receptacle getting wet, position the Brick Saw to one side of a wall mounted receptacle. This will prevent water from dripping onto the receptacle or plug. A “drip loop,” shown in FIGURE 2, should be arranged by the user to properly position the power cord relative to the power source.

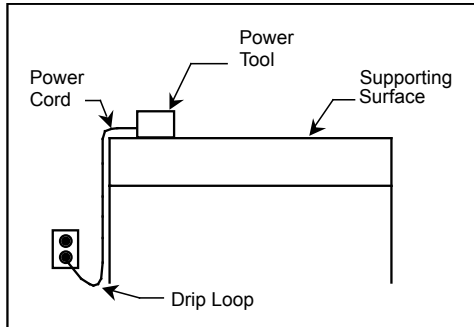

FIGURE 2

- The “drip loop” is that part of the cord below the level of the receptacle, or the connector, if an extension cord is used. This method of positioning the cord prevents the travel of water along the power cord and coming in contact with the receptacle.
- If the plug or receptacle gets wet, DO NOT unplug the cord. Disconnect the fuse or circuit breaker that supplies power to the tool. Then unplug and examine for presence of water in the receptacle.

⚠ WARNING



Use only extension cords that are intended for outdoor use. These extension cords are identified by a marking “Acceptable for use with outdoor appliances; store indoors while not in use.” Use only extension cords having an electrical rating not less than the rating of the product. Do not use damaged extension cords. Examine extension cords before using and replace if damaged. Do not abuse extension cords and do not yank on any cord to disconnect. Keep cords away from heat and sharp edges. Always disconnect the extension cord from the receptacle before disconnecting the product from the extension cord.

⚠ WARNING



To reduce the risk of electrocution, keep all connections dry and off the ground. Do not touch the plug with wet hands.

⚠ WARNING



Use of undersize extension cords result in low voltage to the motor that can result in motor burnout and premature failure. MK Diamond warns that equipment returned to us showing signs of being run in a low voltage condition, through the use of undersized extension cords will be repaired or replaced totally at the customers expense. There will be no warranty claim.

To choose the proper extension cord,

- Locate the length of extension cord needed in TABLE 1 below.
- Once the proper length is found, move down the column to obtain the correct AWG size required for that length of extension cord.

As an example, a fifty (50) foot extension cord would require an AWG size of 12.

| MOTOR SPECS | | | EXTENSION CORD LENGTH | | |
|-------------|-----------|------|-----------------------|-------|------|
| Motor | Voltage | Amps | 25' | 50' | 100' |
| 157801 | 120V 1 Ph | 15 | 14 ga | 10 ga | 8 ga |

TABLE 1

SAFETY LABEL LOCATIONS & SYMBOLS

Safety labels are located according to figure below. The labels contain important safety information. Please read the information contained on each safety label. These labels are considered a permanent part of your saw. If a label comes off or becomes hard to read, contact MK Diamond or your dealer for a replacement.

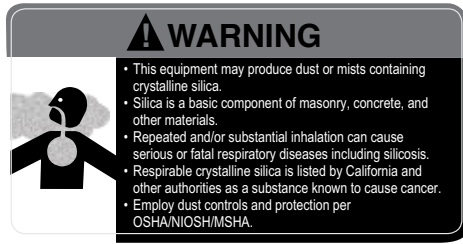

Part # 164202
A



Part # 154398
B



Part # 155038
C



Part # 155587
D

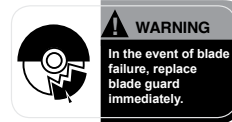

Part # 155588
E

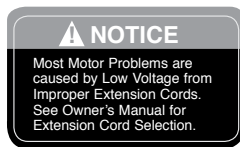

Part # 155672
F



Part # 170480
G



Part # 171241
* H



Part # 165018
* I

* Does not apply to non-misting units

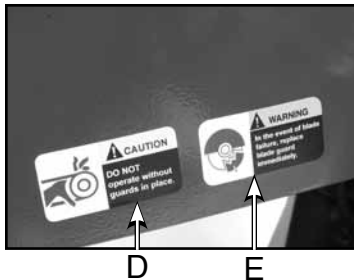

D E

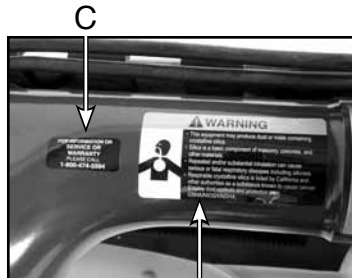

A

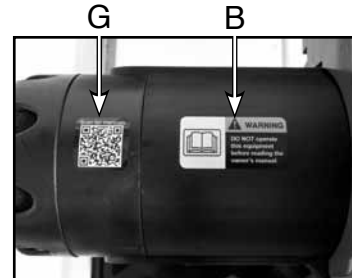

G B

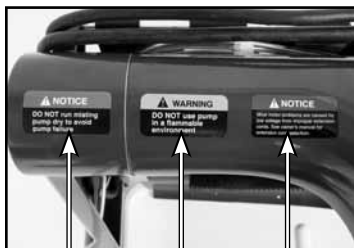

H I F

| Decal | Location | Description |
|-------|-------------|--|
| A | Arm | Warning - Silica |
| B | Motor - Top | Warning - Read Manual |
| C | Arm | Caution - Ground Fault Circuit Interrupter |
| D | Blade Guard | Caution - Guards in Place |
| E | Blade Guard | Warning - Replace Blade Guard |
| F | Arm | Notice - Extension Cord |
| G | Motor - Top | QR Code for Manuals |
| *H | Arm | Notice - Misting Pump |
| *I | Arm | Warning - Pump |

PRODUCT SPECIFICATIONS

PRODUCT SPECIFICATIONS:

The BX-4 is a versatile lightweight, dry, masonry saw. Operated and used according to this manual, the BX-4 will provide years of dependable service.

General Description:

| Part # | Description |
|--------|------------------------------|
| 165486 | With misting dust control |
| 162761 | Without misting dust control |

The BX-4, is engineered as a 14" dry saw with or without misting system. The saw is capable of cutting brick and masonry up to 8" x 8" x 16" in size; the blade has a five (5) inch cutting depth.

Motor and Weight Specifications:

Motor and Weight specifications for the BX-4 are listed in Table 2 below.

| | |
|-----------|-----------------|
| Voltage | 115v |
| Amperage | 15 |
| Frequency | 50-60Hz |
| RPM | 3,500 rpm |
| Weight | 70 lbs. (32 kg) |

TABLE 2

Blade Capacity:

The BX-4 uses a 14-inch diameter segmented dry MK Diamond blade with a .110-inch cutting width.

Masonry Types:

The BX-4 can cut a variety of masonry types including, cinder block, slump stone block, wall brick, paver brick, concrete block and cylinders, roofing tile, marble, granite, decorative rock or almost any other non-ferrous material.

NOTE:

The BX-4 is not designed to cut plastic or ferrous (metals) material.

Spring Assisted Cutting Head:

The BX-4 is designed with a spring assisted Cutting Head to allow for easier step cutting. The Cutting Head can be locked in any down position when cutting smaller pieces.

Lockable Trigger Switch:

The BX-4 is designed with a lockable trigger-operating switch in the handle to allow for ease of operation.

Removable Motor Air Filter:

The BX-4 is designed with an easy clean motor air filter to extend the life of the motor.

Replaceable Motor Brushes:

The BX-4 is designed with replaceable motor brushes to extend operating life.

UNPACKING, TRANSPORT and ASSEMBLY

UNPACKING

- Your BX-4 has been shipped from the factory thoroughly inspected. Only minimal assembly is required.
- If not already done, remove the BX-4 from the carton and place it on a flat surface. Check contents with list below.

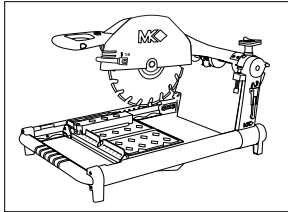

1

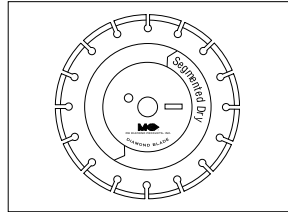

2

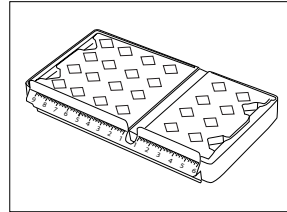

3

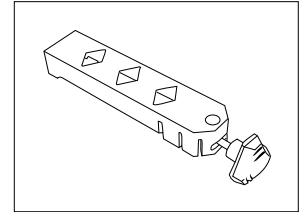

4

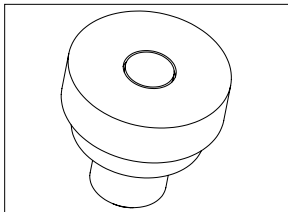

5

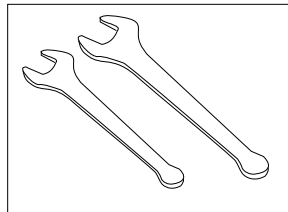

6

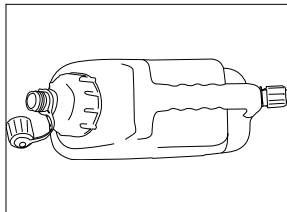

7

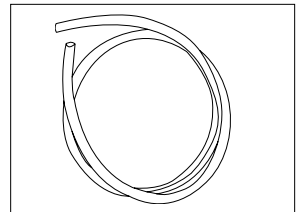

8

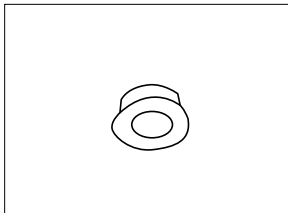

9

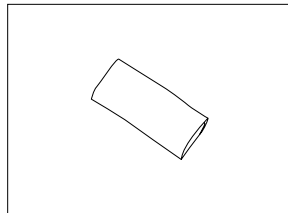

10

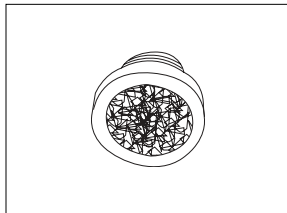

11



12

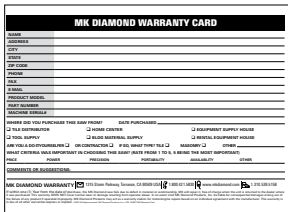

13

CONTENTS:

| Item# | Quantity | Description |
|-------|----------|--|
| 1. | one | BX-4 |
| 2. | one | 14in Wide Slot Segmented Dry Diamond Blade |
| 3. | one | Movable Cutting Table |
| 4. | one | Adjustable Cutting Guide |
| 5. | two | 1mm Misting Nozzles |
| 6. | two | Wrenches |
| 7.* | one | Water Tank |
| 8.* | one | 3/8" x 1/4" Plastic Tubing |
| 9.* | one | Grommets |
| 10.* | one | 1/2" x 3/8" Plastic Tubing |
| 11.* | one | Filter |
| 12. | one | Owner's Manual |
| 13. | one | Warranty Card |

*Items are included in models with misting system

UNPACKING, TRANSPORT & ASSEMBLY

TRANSPORT

The BX-4 weighs approximately seventy (70) pounds (With the Movable Cutting Table), making transport easy.

CAUTION

Always observe safe lifting practices when lifting the BX-4.

NOTE

Lock the Cutting Head in the DOWN position, and remove the Movable Cutting Table when transporting the BX-4.

Due to its lightweight construction, the BX-4 is designed to be carried by the handles at the front & back of the saw. Simply lock (1) the spring assisted Cutting Head in position (2), by tightening the Tri-Knob. Grasp the frame by the lower front and rear cross members (3,4). Lift and transport the BX-4 to the desired work location.

- Slide Table Lock to engage or disengage pin into or out of notches in the Side Rail for transportation or operation.

ASSEMBLY

Follow the assembly instructions to prepare your BX-4 for operation.

1. MOVABLE CUTTING TABLE INSTALLATION:

- Identify front side of Cutting Table (5).
- Seat Roller Wheels (6) of the Movable Cutting Table within the guide rails.
- Verify correct seating and ease of Cutting Table movement. See Maintenance Section if problems arise.

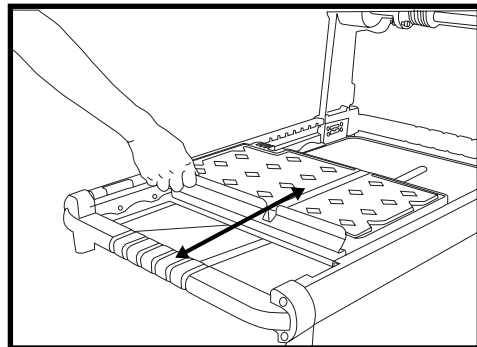
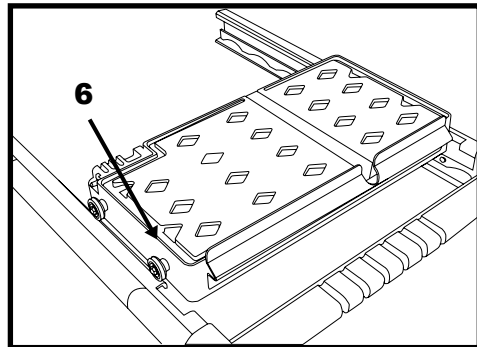
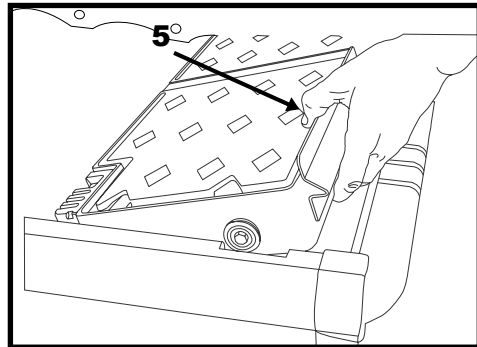
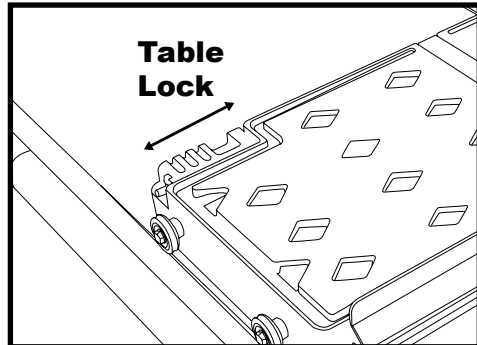
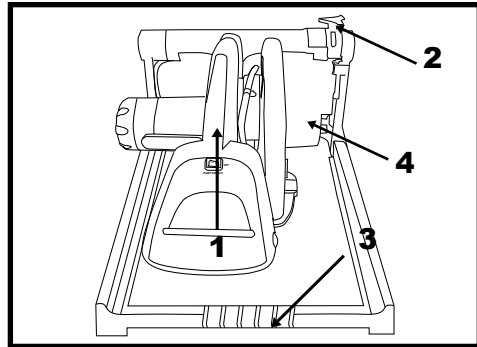

UNPACKING, TRANSPORT & ASSEMBLY

2. DIAMOND BLADE INSTALLATION:

NOTE

When installing the Retaining Screw, do not “cross-thread” and DO NOT over tighten the screw.

- Identify Motor Shaft, Retaining Screw (1) and Outer Flange (2).

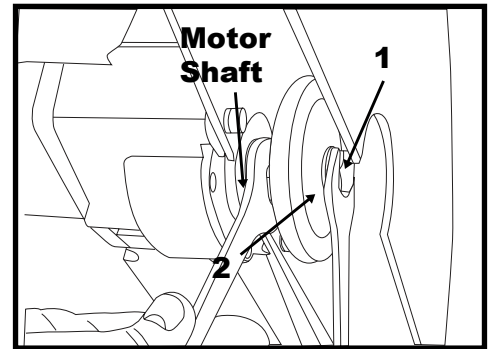

- Hold Shaft Wrench (3) stationary. Rotate Blade Wrench (4) counter-clockwise. Remove Retaining Screw and Outer Flange.

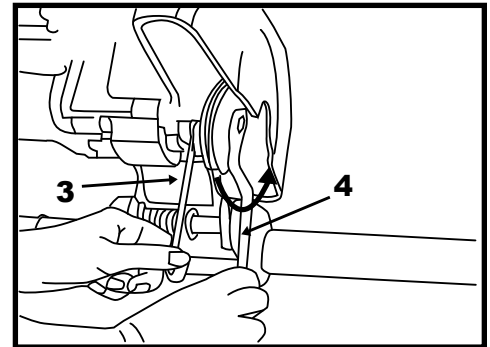

- Seat Blade (5) on Inner Flange (6). Verify rotation direction of blade.

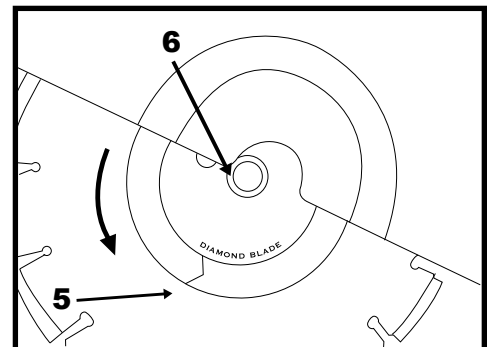

- Hold Shaft Wrench (3) stationary. Rotate Blade Wrench (4) clockwise. Install Retaining Screw (8) and Outer Flange (7) & tighten.

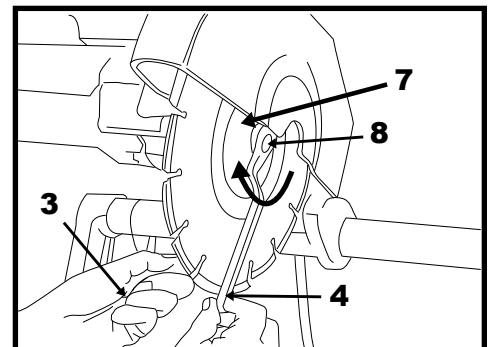

SETUP, ADJUSTMENT & OPERATION

SETUP:

⚠ CAUTION

- Before powering or starting, check for damage that could prevent this equipment from proper operation or performing its intended function. Check for binding and alignment of moving parts. Check for damaged, broken, or missing parts.
- Verify the trigger switch, locking button is in the "RELEASE" position.
- Before connecting the BX-4 to a power supply, be sure the voltage, cycle and phase of the job site power source meet the requirements listed in TABLE 3.
- If using an extension power cord, make sure the length and wire gauge corresponds to the requirements listed in TABLE 1 on page 8. An extension power cord that is too small in wire gauge (diameter), or too long in length, will cause the motor to overheat and could cause premature failure.
- Use an approved Ground Fault Circuit Interrupter (GFCI).
- Do not cover the motor vents as this could lead to motor overheating.

PORTABLE GENERATOR:

If using a portable generator to provide power, ensure the generator meets the following minimum requirements listed in Table 4:

⚠ CAUTION

If cutting dry, ensure that pump switch is in the OFF position.

⚠ CAUTION

If cutting wet, water container must be full of clean water & plastic tube fully inserted in container with filter installed. (See page 33 for complete instructions)

NOTE

Lack of adequate water to pump, while pump is on will shorten pump life & quickly cause pump failure.

| | |
|----------|--------------|
| VOLTAGE: | 115v |
| CYCLE: | 50-60Hz |
| PHASE: | Single Phase |

TABLE 3

| | | | |
|------|---------------|----------------|--------------|
| 8 kW | 120/240 volts | 66.7/33.3 amps | Single Phase |
|------|---------------|----------------|--------------|

TABLE 4

SETUP, ADJUSTMENT & OPERATION

PRE-START INSPECTION:

The pre-start inspection should be performed before beginning any job.

NOTE

In order to avoid breaker tripping, a 20-amp circuit breaker should be used.

CAUTION

If the Diamond Blade shows signs of fatigue cracking, replace the blade before starting work.

- Inspect Blade for damage (1). Verify that the Blade is correct for the material being cut.
- Inspect Wooden Strip (2) for excessive grooves.
- Ensure that the Movable Cutting Table (3) moves freely. See Maintenance Section if problems arise.
- Inspect other areas for damage, including the Frame Assembly (4), Motor Mount Assembly (5), Handle and Cord Assembly (6) and Table Assembly (7).

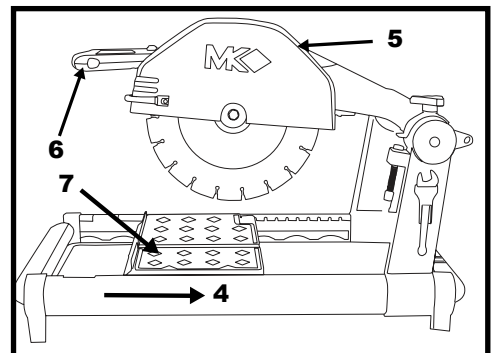
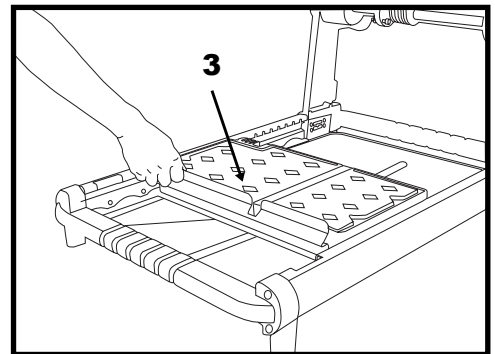
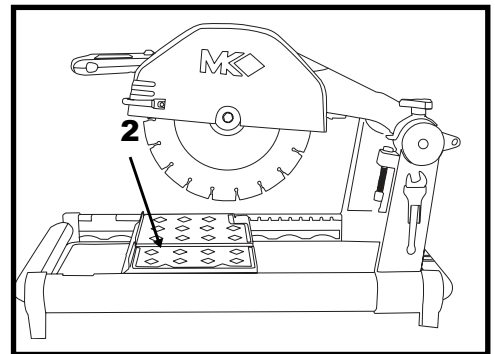
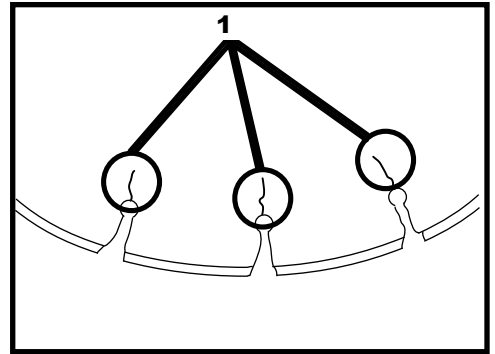

SETUP, ADJUSTMENT & OPERATION

PRE-START INSPECTION:

- Inspect Motor Air Filter (1) condition if required, shake or tap to remove excess debris. (See Cleanup Page 23)

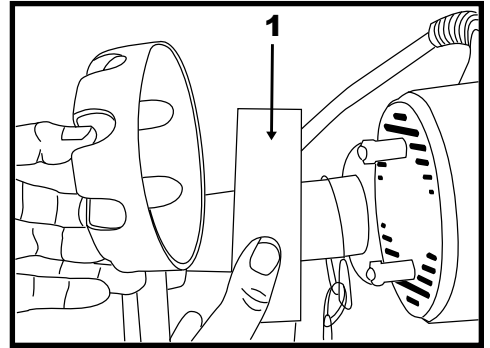

- Verify that the Trigger Switch (2) on the underside of the handle is unlocked. Depress release button (3) to unlock trigger.

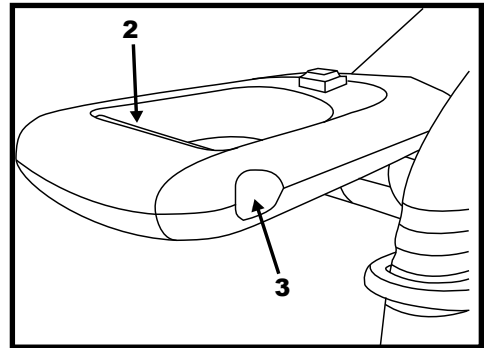

CAUTION

If an extension cord is used, first verify it meets the requirements of TABLE 1 (page 8). Plug the BX-4 into the extension cord; plug the extension cord into a Ground Fault Circuit Interrupter (GFCI). Finally, plug the GFCI into the power source in that order.

- Plug the Ground Fault Circuit Interrupter (GFCI) into the BX-4.
- Plug the GFCI into a power source.

SETUP, ADJUSTMENT & OPERATION

ADJUSTMENT AND OPERATION:

1. ADJUSTABLE CUTTING GUIDE INSTALLATION:

- Loosen knob (1) by turning counter-clockwise.
- Seat the Adjustable Cutting Guide (2) along the Ruler/Stop (3). Turn knob (1) clockwise to tighten.

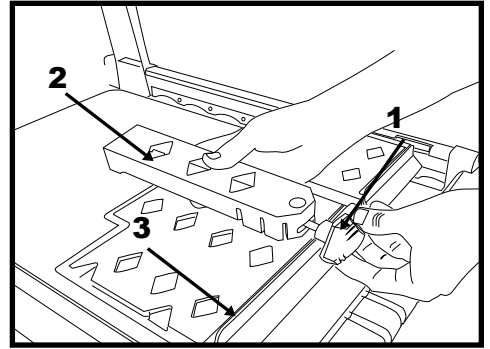

2. CUTTING SETUP:

- Set the Adjustable Cutting Guide (1). Identify the Ruler/Stop (2). Set the edge of the Cutting Guide to the desired cut length on the Ruler/Stop.
- Position your masonry piece by setting it against the Adjustable Cutting Guide (1) and Ruler/Stop (2).

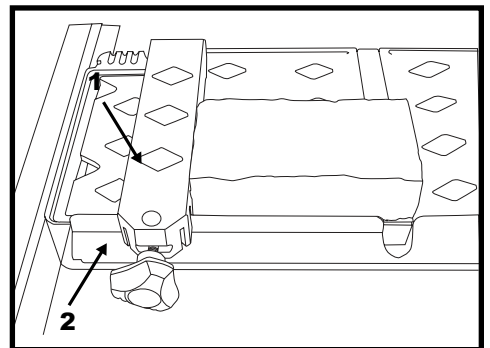
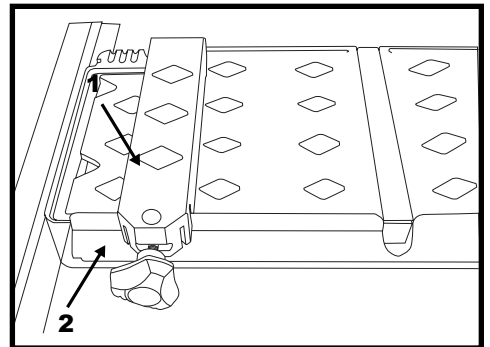

CAUTION

DO NOT FORCE the blade to cut! It will do the job better and safer at the rate for which it was designed.

SETUP, ADJUSTMENT & OPERATION

2. STEP CUTS:

A Step Cut is performed when a series of small cuts of increasing depth are used to complete a single cut. Step Cuts are used for large objects or for hard objects such as firebrick and pavers.

NOTE

1. Step Cutting is the preferred cutting method for all cuts.
2. When cutting hard material Step Cutting should always be used.
3. Step Cutting will extend the life of the Diamond Blade.

- Step cut setup: Depress Trigger (1) to start (depress lock button (2) to lock trigger in place if desired). Hold (3) work in position.
- Step cut “push” stroke: Using the Handle (4), lower the Cutting Head 1/4-1/2 inch during the “push” stroke. Push the Casting Table (5) away from you.
- Step cut “pull” stroke: Using the Handle (4), lower the Cutting Head an additional 1/4-1/2 inch during the “pull” stroke. Pull the Casting Table (5) towards you.
- Repeat “push” and “pull” strokes until the cut is complete.
- When the cut is complete, release the Trigger (1). (Depress lock button (2) to release trigger if required). Allow the Blade to stop before removing work. Using the Handle (4) to raise the Cutting Head.

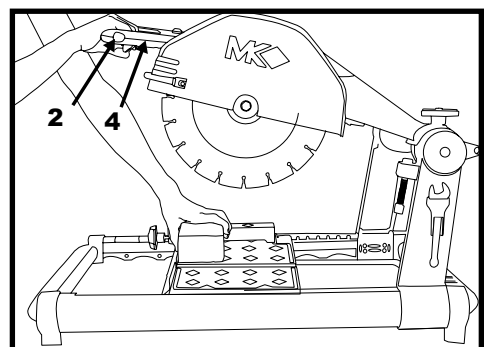
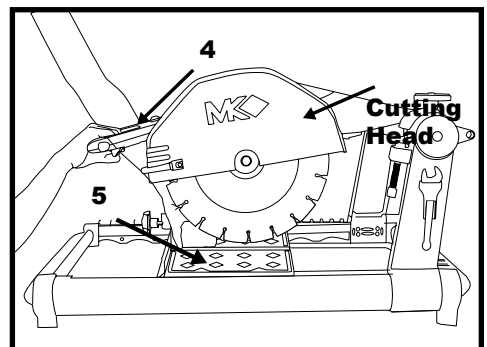
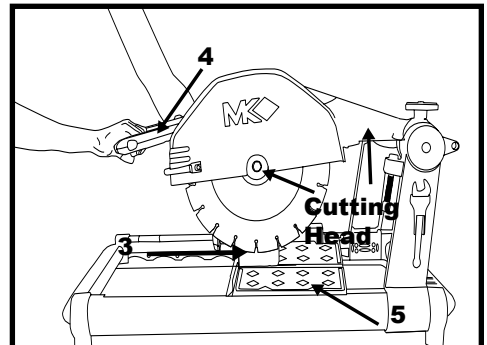
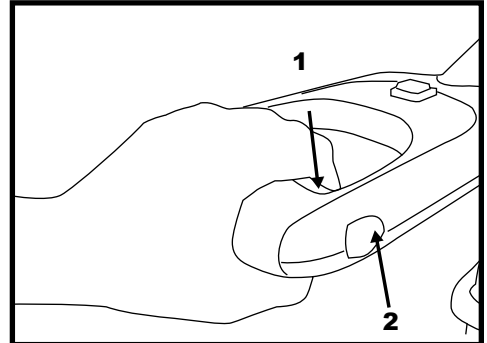

SETUP, ADJUSTMENT & OPERATION

3. CHOP CUTTING:

- A Chop Cut is performed by cutting completely through an object in one pass.
- Chop cut setup: Depress Trigger to start (lock if desired). Position work (1) below the Blade.
- Hold Cutting Table (2) stationary. Using the Handle (3), lower the Cutting Head to begin cutting.
- Using the Handle (3), continue to lower the Cutting Head until the cut is complete.
- When the cut is complete, release the Trigger Switch. Allow the Blade to stop before removing work. Using the Handle (3) to raise the Cutting Head.

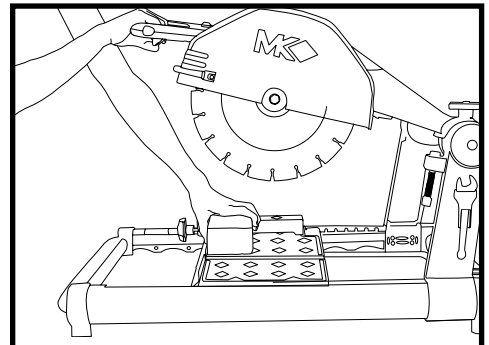
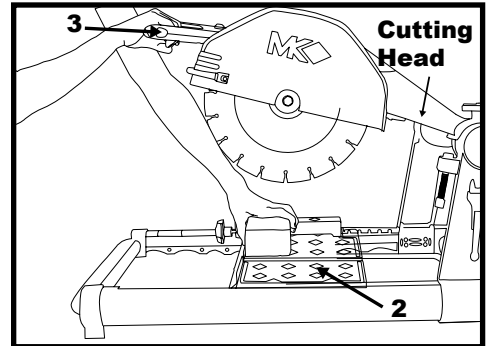
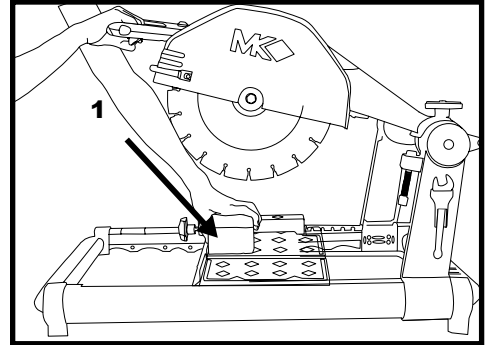

SETUP, ADJUSTMENT & OPERATION

4. CUTTING WITH THE CUTTING HEAD LOCKED DOWN:

This method is preferred when cutting small objects.

- Set adjustable depth control by depressing button on side of control (1) and moving Depth Control Screw (2) up or down to desired position. Fine adjustments can be made by turning depth control screw. Tighten Tri-Knob (3) to hold Cutting Head in position.

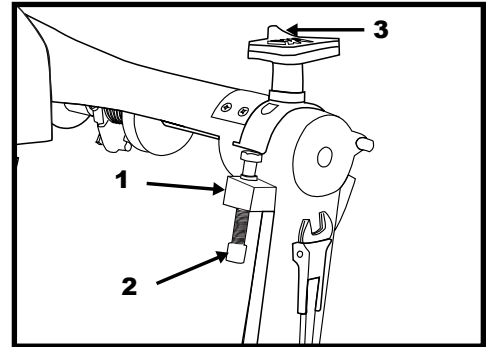

- Hold work in position, depress trigger to start motor. Depress lock button (3) to hold trigger if desired.

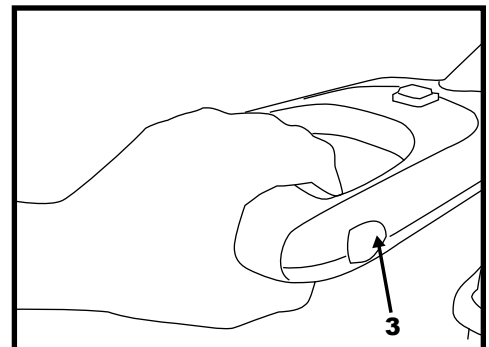

- Slowly push the Table towards the Blade to begin cutting.

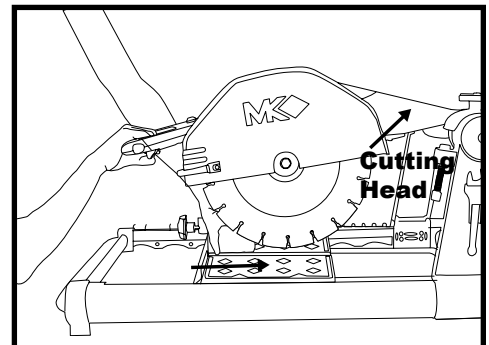

- Continue to push work into the Blade until the cut is complete. Unlock the Trigger Switch. Allow the Blade to stop moving before removing the work.

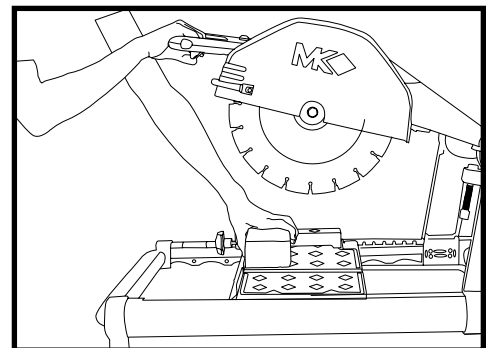

SETUP, ADJUSTMENT & OPERATION

5. ANGLE CUTS:

- Angle Cuts may be performed using the Step Cut, Chop Cut or the Locked Cutting Head cutting methods. The following is utilizing the Locked Cutting Head method.
- Loosen the knob (1) and remove the Adjustable Cutting Guide (2).
- Reposition the Adjustable Cutting Guide (2) by aligning it at 45 degrees to slots on the Ruler/Stop (3).
- Position masonry work (4) against the Adjustable Cutting Guide (2) and Ruler/Stop (3).
- Set Depth Control (5) & lock cutting head with knob (6). (See Page 20)
- Hold the masonry work in position. Lock the trigger switch.

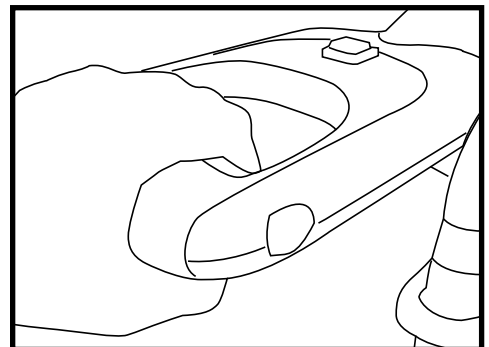
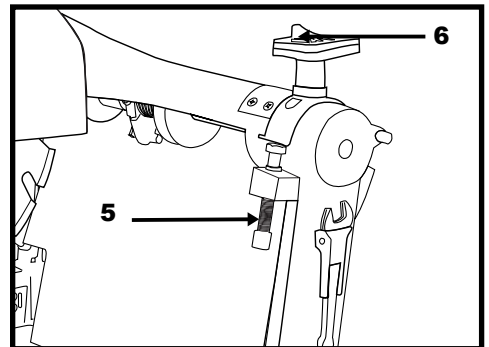
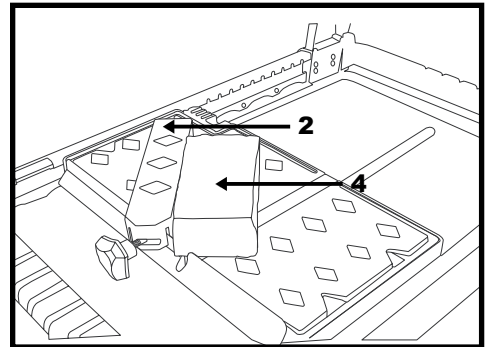
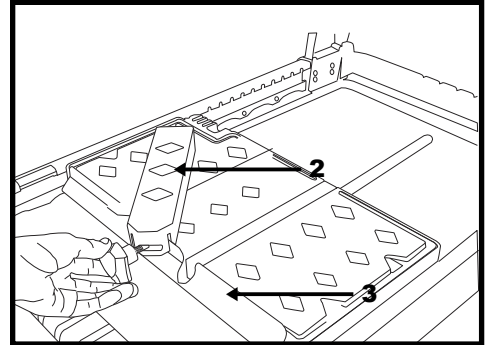
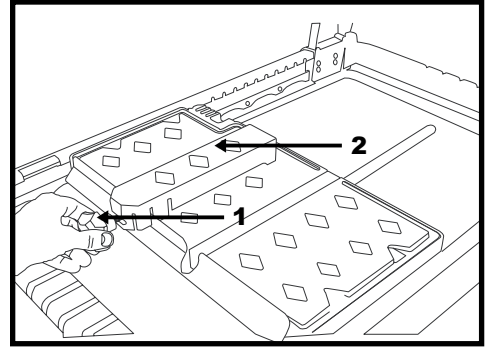

SETUP, ADJUSTMENT & OPERATION

5. ANGLE CUTS CONTINUED:

CAUTION

DO NOT FORCE TOOL! It will do the job better and safer at the rate for which it was designed.

- Slowly push the masonry work towards the Blade to begin the cut.
- Continue to push the masonry work into the Blade until the cut is complete.

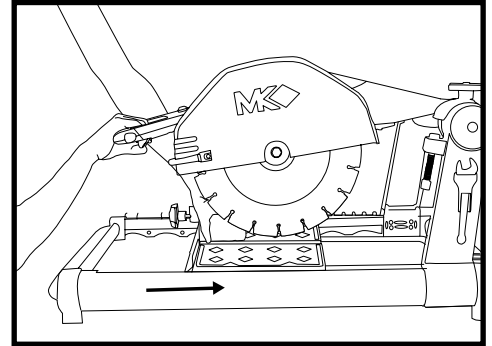

- Unlock the Trigger Switch.

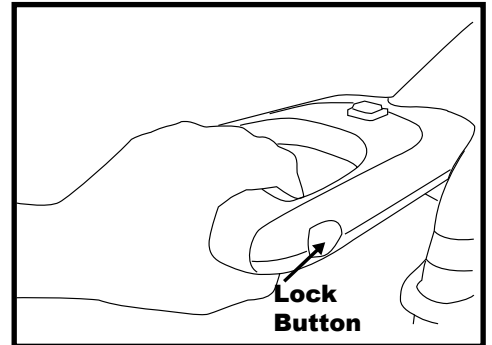

- Allow the Blade to stop before removing the work.

SETUP, ADJUSTMENT & OPERATION

6. CLEANUP:

WARNING

- Always wear eye protection when using compressed air.
- Disconnect unit from power supply & unplug GFCI from BX-4.

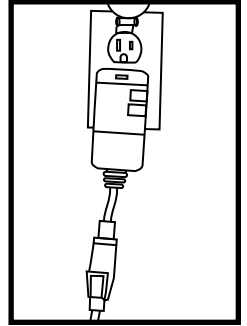

- Pull straight back to remove the Motor Filter Cap (1).

- Pull Foam Filter (2) out of the Filter Cap,

(Clean Foam Filter by tapping it on a hard surface or by using compressed air to dislodge dirt).

- Reinstall the Foam Filter into the Filter Cap.

- Align the Filter Cap Retaining Hole with the Spacer Pins (3). Push the Filter Cap (1) onto the Spacer Pins to seat onto Motor.

- Clean the Movable Cutting Table Roller Wheels and Guide Rails.

- * Clean build up of debris from Splash Curtain.

- Clean the remainder of the BX-4 with a clean cloth.

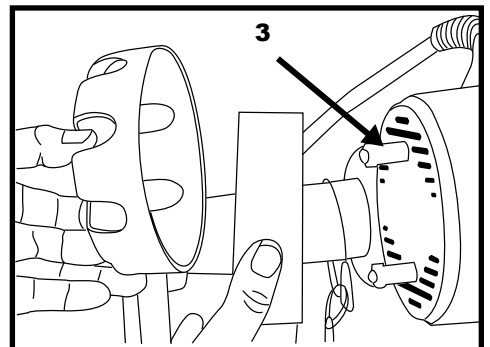
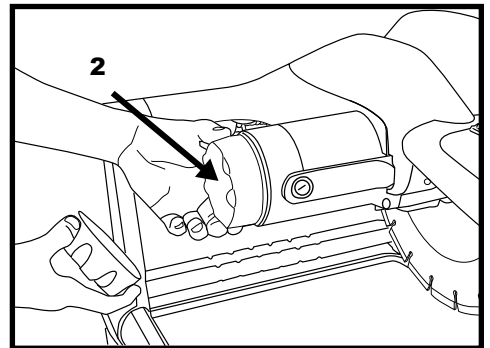
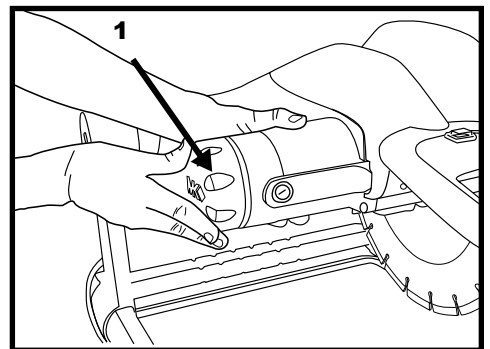

MAINTENANCE & TROUBLESHOOTING

MAINTENANCE:

1. GENERAL MAINTENANCE:

- The following maintenance should be performed following each use. Use light oil, such as WD-40 or 3-in-1 when lubricating parts.
- Lubricate the Cutting Head Torsion Spring.
- Lubricate the Movable Cutting Table Roller Wheels & Guide Rails.

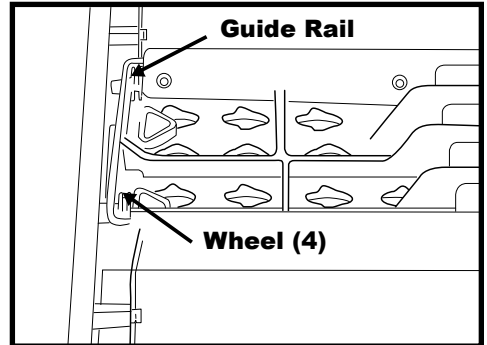
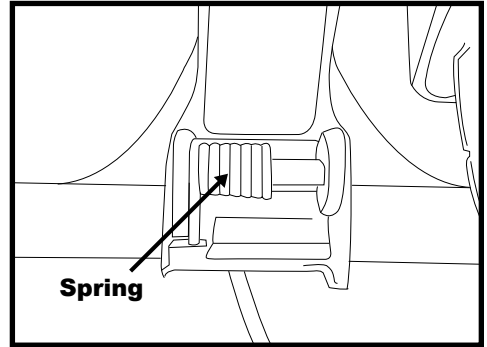

2. MONTHLY MAINTENANCE:

The following should be performed monthly. Items should be lubricated as directed.

- Clean and lubricate Inner Flange (1) and Motor Shaft.
- Clean and lubricate the Blade Retaining Screw (2).
- Check Roller Wheels (3) and Guide Rails (4) for wear or damage.

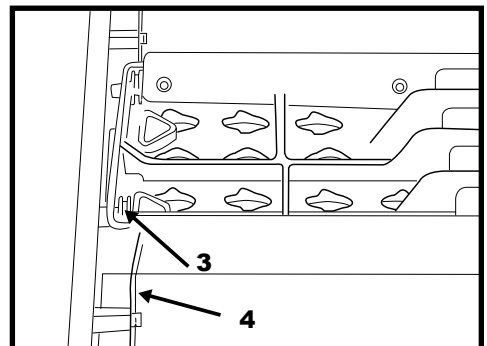
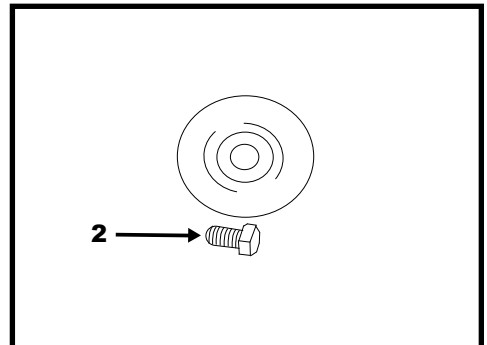
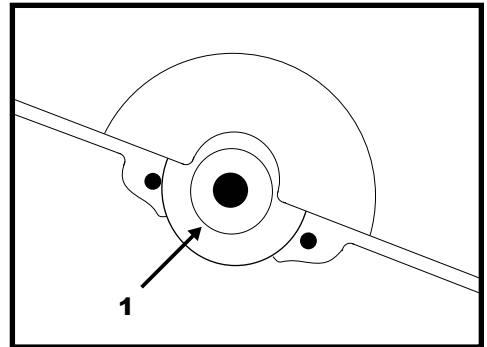

MAINTENANCE & TROUBLESHOOTING

3. BLADE DRESSING:

Diamond Blades perform best when dressed. Over time and use, diamonds on the outer edge of the blade will become smooth or “glazed” over. This will reduce grinding efficiency and may cause the blade to “wander” or bend, giving the illusion of an alignment problem. When this occurs, the blade will need to be dressed. The diamond blade can be dressed using the MK Dressing Stick (Part# 152792) and by following the steps below.

- Set up the BX-4 for operation (See Setup, Adjustment and Operation section).
- Position Dressing Stick against Table Back stop.
- Note the Ruler measurement markings. Set the Adjustable Cutting Guide to cut 1/16-inch strips. Ruler/Stop to cut off approx. 1/16-inch strip. Position the Dressing Stick (1) against the Adjustable Cutting Guide and Ruler/Stop.

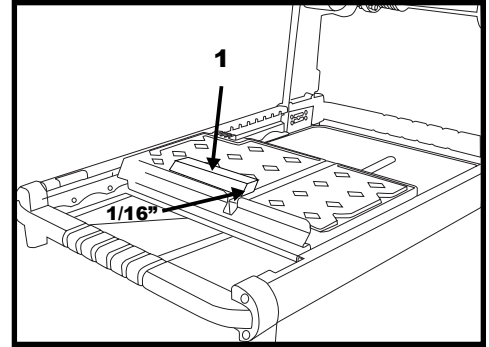

CAUTION

DO NOT FORCE TOOL! It will do the job better and safer at the rate for which it was designed.

- Hold the Dressing Stick (1) in position. Depress the Trigger to start (lock if desired).
- Lower the Cutting Head while pushing the Dressing Stick toward the Blade.
- Repeat the cut stroke 8 times.
- Release the Trigger Switch. Raise the Cutting Head. Allow the Blade to stop before removing the Dressing Stick.

MAINTENANCE & TROUBLESHOOTING

4. DIAMOND BLADE CHANGE-OUT:

WARNING

Disconnect the tool before servicing and when changing accessories, such as blades, bits, cutters, and the like.

- Remove Retaining Screw (1) and Outer Flange (2): Hold Shaft Wrench (3) stationary. Rotate Retaining Screw counter-clockwise to loosen screw.
- Remove Blade from Motor Shaft.
- Seat Blade on the Inner Flange (4) under Blade Guard and onto Motor Shaft. Note the indicated rotation direction.
- Install Outer Flange (2) and Retaining Screw (1): Hold Shaft Wrench (3) stationary. Rotate and tighten Retaining Screw (1) clockwise.

NOTE: When installing the Retaining Screw, do not “cross-thread” and DO NOT over tighten the screw.

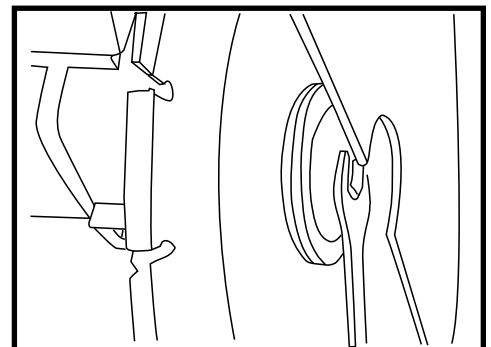
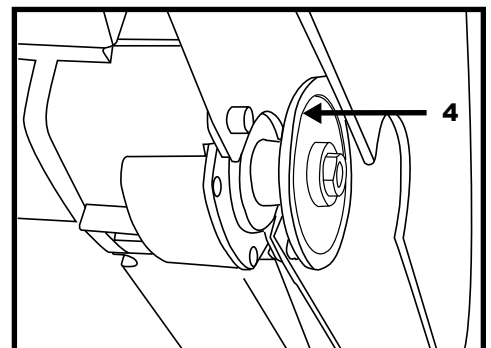
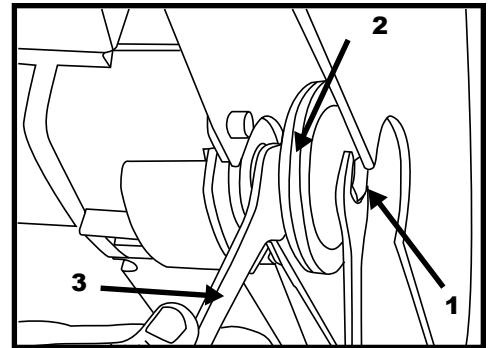

MAINTENANCE & TROUBLESHOOTING

5. MOVABLE CUTTING TABLE WHEEL CHANGE-OUT:

NOTE: All four (4) Movable Cutting Table Roller Wheels should be replaced at the same time (MK Diamond Part # 133090).

- Place Movable Cutting Table on work bench with Roller Wheels up.
- Using a 1/2-inch wrench to hold hex nut, hold Roller Wheel rotating nut stationary, rotate the Roller Wheel counter-clockwise with 3/16" hex key wrench to remove.
- Prepare for installation of new Roller Wheels by cleaning the Roller Wheel holes.
- Install Wheel/Washer assembly into Movable Cutting Table.
- Using a 1/2-inch wrench, rotate the Roller Wheels counter-clockwise to install Roller Wheel Retaining Nut.

NOTE: When installing the Retaining Bolt, Do Not cross-thread and DO NOT over tighten the nut.

- Lubricate Roller Wheels with light oil (WD-40 or 3-in-1, etc.)
- Install Movable Cutting table move table to check for smoothness of movement.

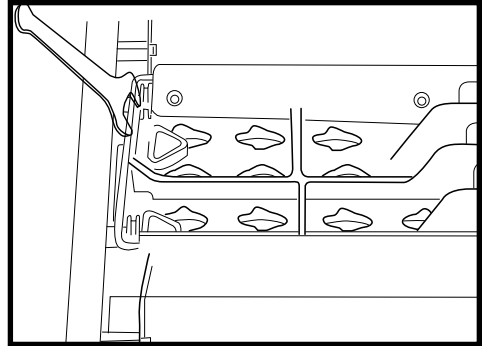

MAINTENANCE & TROUBLESHOOTING

6. PROTECTIVE WOODEN STRIP REPLACEMENT:

The protective wooden strip is provided to protect the Movable Cutting Table from damage during operation. Over time, the wooden strip will become grooved from use. A grooved wooden strip will not support masonry during cutting, causing the blade to “break through” the piece instead of performing a smooth cut (MK Diamond Part # 156427).

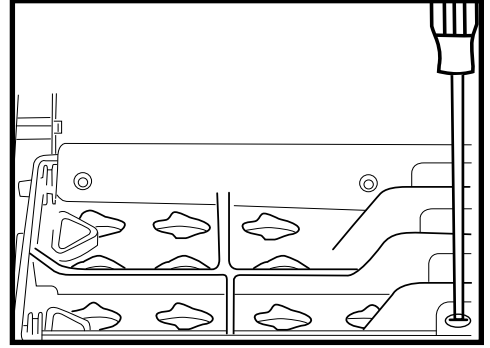

Place Movable Cutting Table on work bench with Roller Wheels facing upwards.

- Using a Phillips Screwdriver, remove the two Protective Wooden Strip Retaining Screws.
- Replace worn Strip with new Protective Wooden Strip. Secure with two Retaining Screw with Phillip Screwdriver.
- Install Movable Cutting Table. See Setup, Adjustment and Operation section.

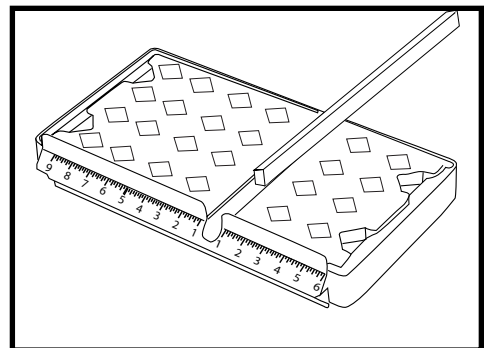
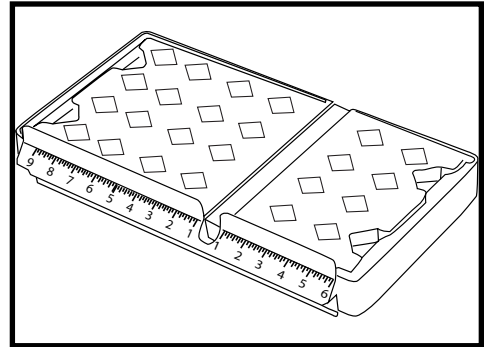

MAINTENANCE & TROUBLESHOOTING

4. MOTOR-BRUSH REPLACEMENT:

WARNING

Disconnect the tool before servicing and when changing accessories, such as blades, bits, cutters, and the like.

- Insert a screwdriver into the Motor Brush Cap. Rotate counter-clockwise and remove the Cap. Repeat on the other side of the Motor.
- Remove the Motor Brush. Clean the Brush Housing of all carbon dust and fragments.
- Align a new Motor Brush with the Brush Housing. Insert the new Motor Brush.
- Replace the Motor Brush Cap. Using the screwdriver, rotate clockwise to secure in place.
- Using this same method, install a new Motor Brush on the other side of the Motor.

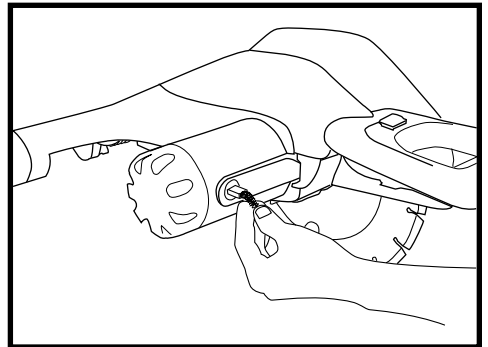
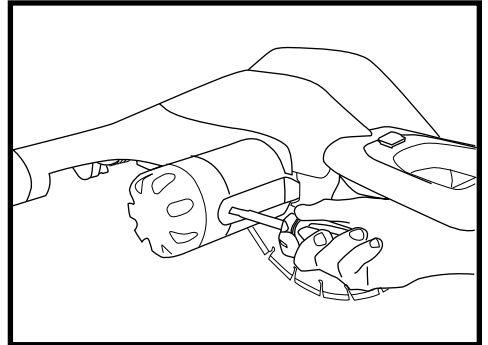

MAINTENANCE & TROUBLESHOOTING

TROUBLESHOOTING:

WARNING

Verify the Lockable Switch is unlocked and the saw is disconnected from the power source before performing any troubleshooting procedure.

1. MOTOR STOPS TURNING:

Step A: Verify all plugs are fully connected. If connected, proceed to Step B.

Step B: Check that the Ground Fault Circuit Interrupter (GFCI) is tripped. If GFCI is tripped, reset and restart the BX-4 once. If GFCI is not tripped, proceed to Step C.

Step C: Verify that the circuit breaker is 20 amps or greater. If less than 20 amps, switch to 20 amp breaker. If 20 amps or greater, proceed to Step D.

Step D: Verify that the circuit breaker is not tripped. If breaker is tripped, reset once and attempt to restart. If circuit is not tripped, proceed to Step E.

Step E: Verify source voltage is 115 volts. If circuit is not 115 volts, change the circuit. If circuit is 115 volts, contact place of purchase or MK Diamond (800) 421-5830.

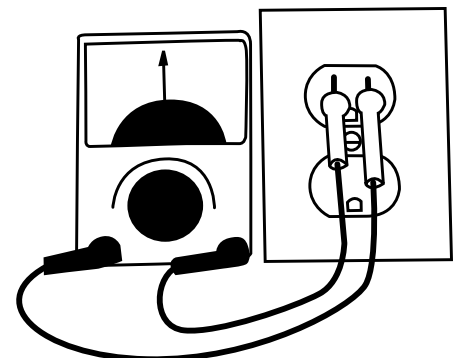
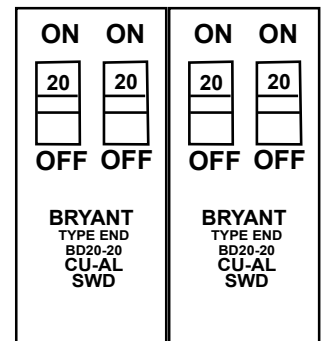
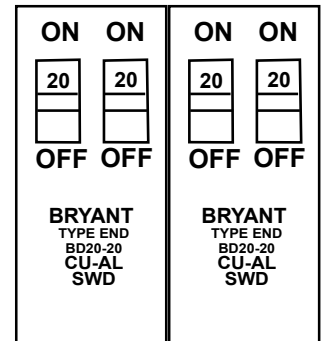
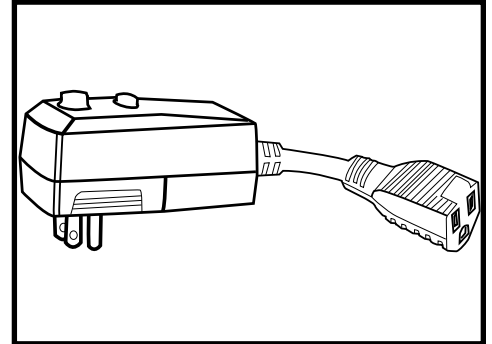

MAINTENANCE & TROUBLESHOOTING

2. BLADE WILL NOT CUT PROPERLY:

Step A: Check for smoothness or “glazing”. If “glazed,” dress Blade. See Blade Dressing section. If not “glazed,” proceed to Step B.

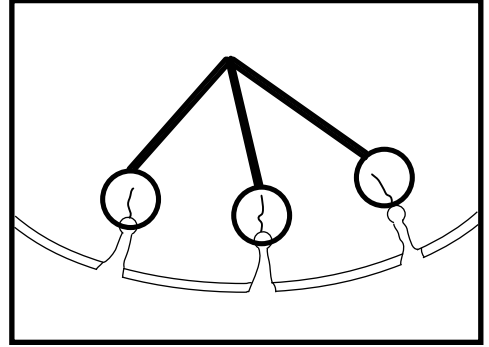

Step B: Check for proper rotation. If rotation is not correct, reposition the Blade. If rotation is correct, proceed to Step C.

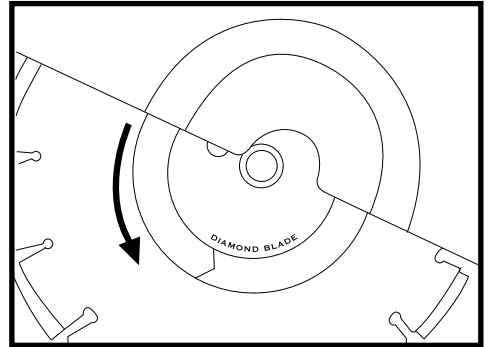

Step C: Ensure the Blade core is not bent. If core is bent, change Blade. If core is not bent, proceed to Step D.

Step D: Verify the correct Blade is being used of the material. Contact the place of purchase or MK Diamond (800) 421-5830 for additional assistance.

MAINTENANCE & TROUBLESHOOTING

3. MOVABLE CUTTING TABLE DOES NOT MOVE CORRECTLY:

Step A: Check that the Guide Rails (1) are clean. If dirty, clean the rails. If clean, proceed to Step B.

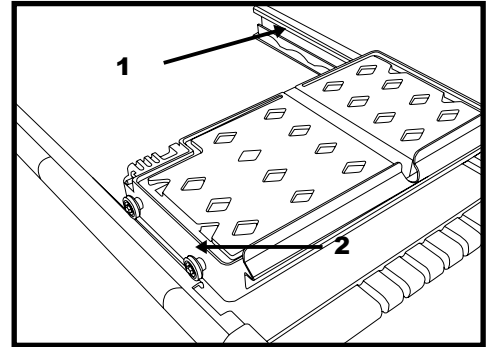

Step B: Check for Roller Wheel (2) damage. If damaged, replace the Roller Wheels. If not damaged, proceed to Step C.

Step C: Verify the correct Blade is being used of the material. Contact the place of purchase or MK Diamond (800) 421-5830 for additional assistance.

MISTING SYSTEM OPERATION, MAINTENANCE & TROUBLESHOOTING

CAUTION

Do Not Run Pump Dry.
Pump damage may result if adequate water flow is not present.

OPERATION:

Pump, tubes, fittings & nozzles are pre-installed & inspected at factory. Set-up cutting with dust suppression system is accomplished by filling up Water Tank, Closing Cap, & pushing Tube into Push-to-Connect Coupling (6).

Step A: Fill up water tank with fresh clean water. Push 3/8" x 1/4" tube (1) thru grommet & into a 1/2" x 3/8" x 1-1/2" tube (2). Push (2) into a plastic filter.

Step B: Drop filter into the water tank. Ensure the filter is sitting on the bottom of the tank.

Step C: Screw cap (5) onto the water tank.

Step D: Push other end of tube into push-to-connect coupling (6).

NOTE: A full tank of water will last about 2-1/2 hours at continuous operation.

Step E: Push pump switch (7) to "ON" position.

NOTE: I - ON , O - OFF

Step F: Depress trigger switch to start motor & misting pump. Mist should be seen within 5 seconds.

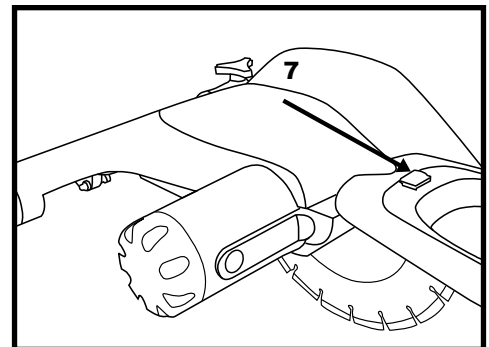
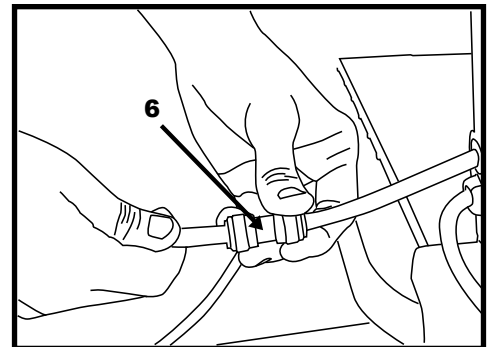
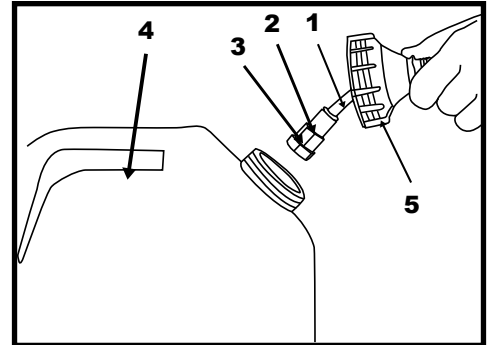

MISTING SYSTEM OPERATION, MAINTENANCE & TROUBLESHOOTING

CAUTION

Disconnect unit from power supply.

REPLACEMENT OF NOZZLES:

Step A: Remove tube cover (1) by loosening 2 screws on both side of blade guard with a phillips screw driver.

Step B: Remove blade.

Step C: Remove 2 retaining rings which hold nozzles in place from the inner side of blade guard.

Step D: Loosen nozzles by rotating counter-clockwise.

Step E: Install new nozzles. Push fittings thru holes in the blade guard & secure fittings by reinstalling retaining rings from the inner side.

Step F: Re-install tube cover (1). Secure tube cover with phillip screws.

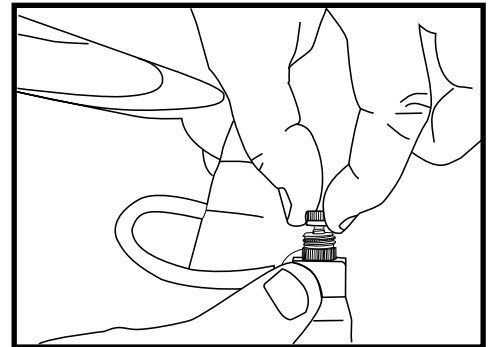
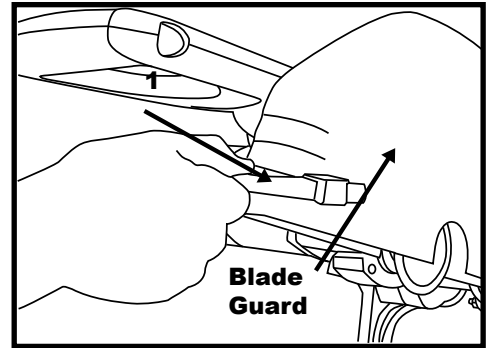

MISTING SYSTEM OPERATION, MAINTENANCE & TROUBLESHOOTING

CAUTION

Disconnect unit from power supply.

REPLACEMENT OF PUMP:

Step A: Using 4 mm hex key, remove 4 Pump cover Retaining Screws.

Step B: Remove pump cover (1).

Step C: Disconnect electric terminals from pump.

Remove tubes from both ends of pump. (Visually inspect tube condition. Replace tubes, if necessary).

Step D: Re-connect electric terminals & tubes to pump.

Step E: Secure tubes with tube clamps.

Step F: Position & hold pump in the Cutting Head with Pump Cover (1). Secure all screws.

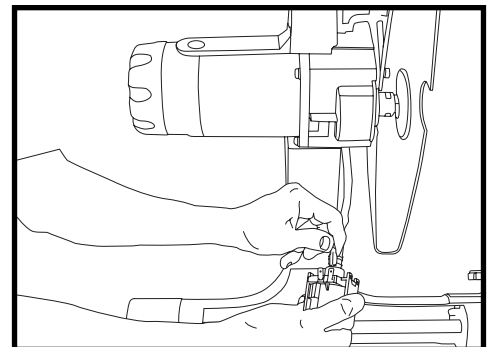
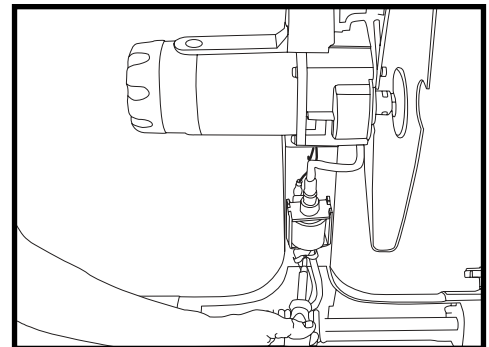
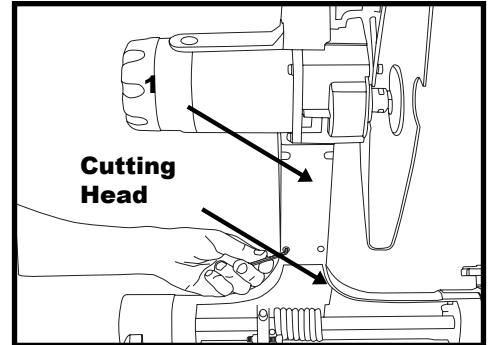

CAUTION

Bent or kinked tubes may prevent free flow of water and may shorten pump life.

MISTING SYSTEM TROUBLESHOOTING

NO MIST:

Step A: Check Pump Switch & Saw are on.

Step B: Remove Nozzle & inspect. Nozzle should be open & free of all debris

Step C: Inspect water intake filter. Ensure filter is free of excess debris & water in container is clean.

Step D: Ensure tubing is undamaged & free of kinks or sharp bends.

Step E: Check tubing connectors to ensure tubing is fully inserted in connector.

Step F: Check Pump to ensure it is operating properly. If not, contact MK Diamond.

BRICK SAW ELECTRICAL WIRING DIAGRAM

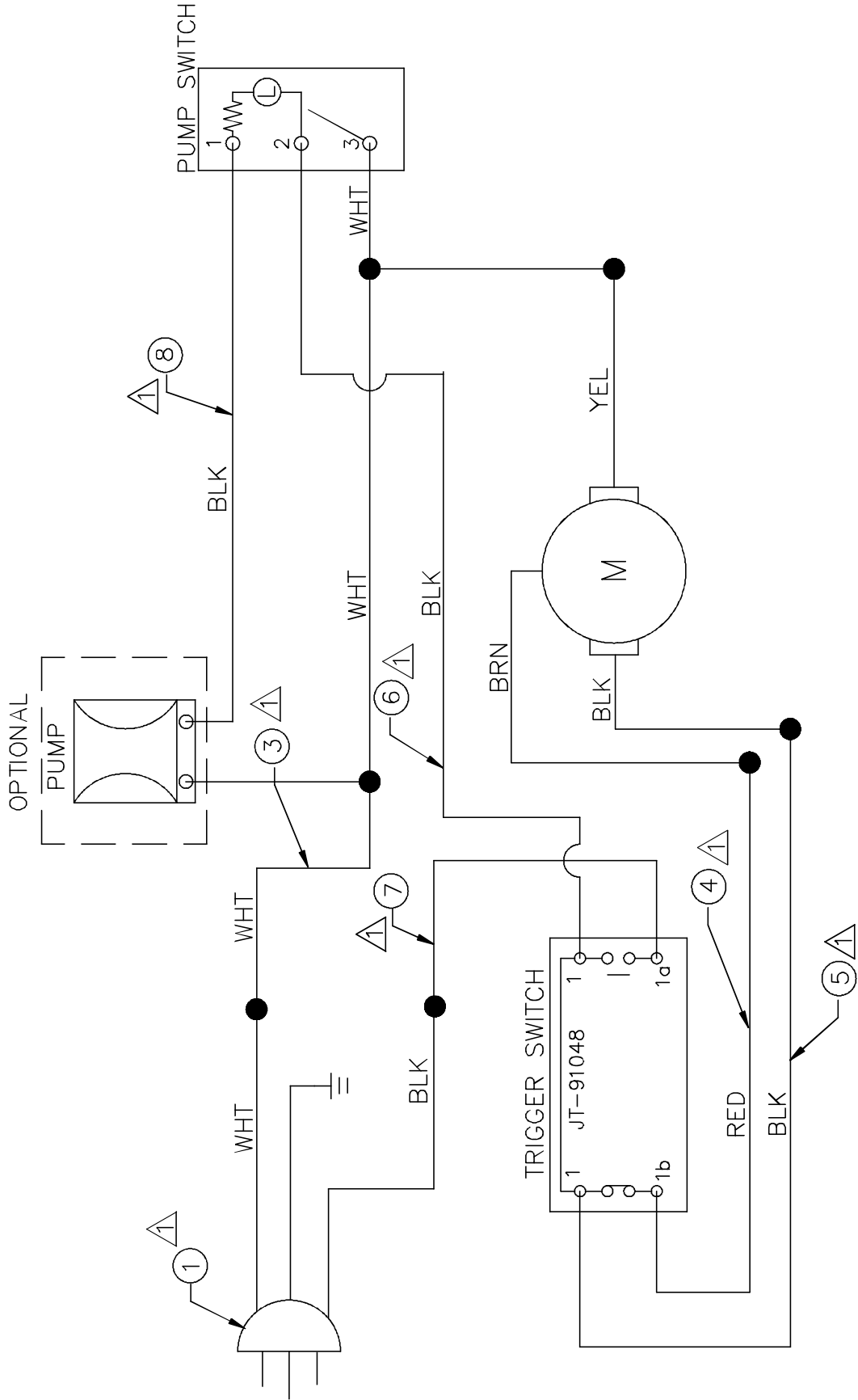

ASSEMBLY FINAL (WITHOUT MISTING COMPONENTS)

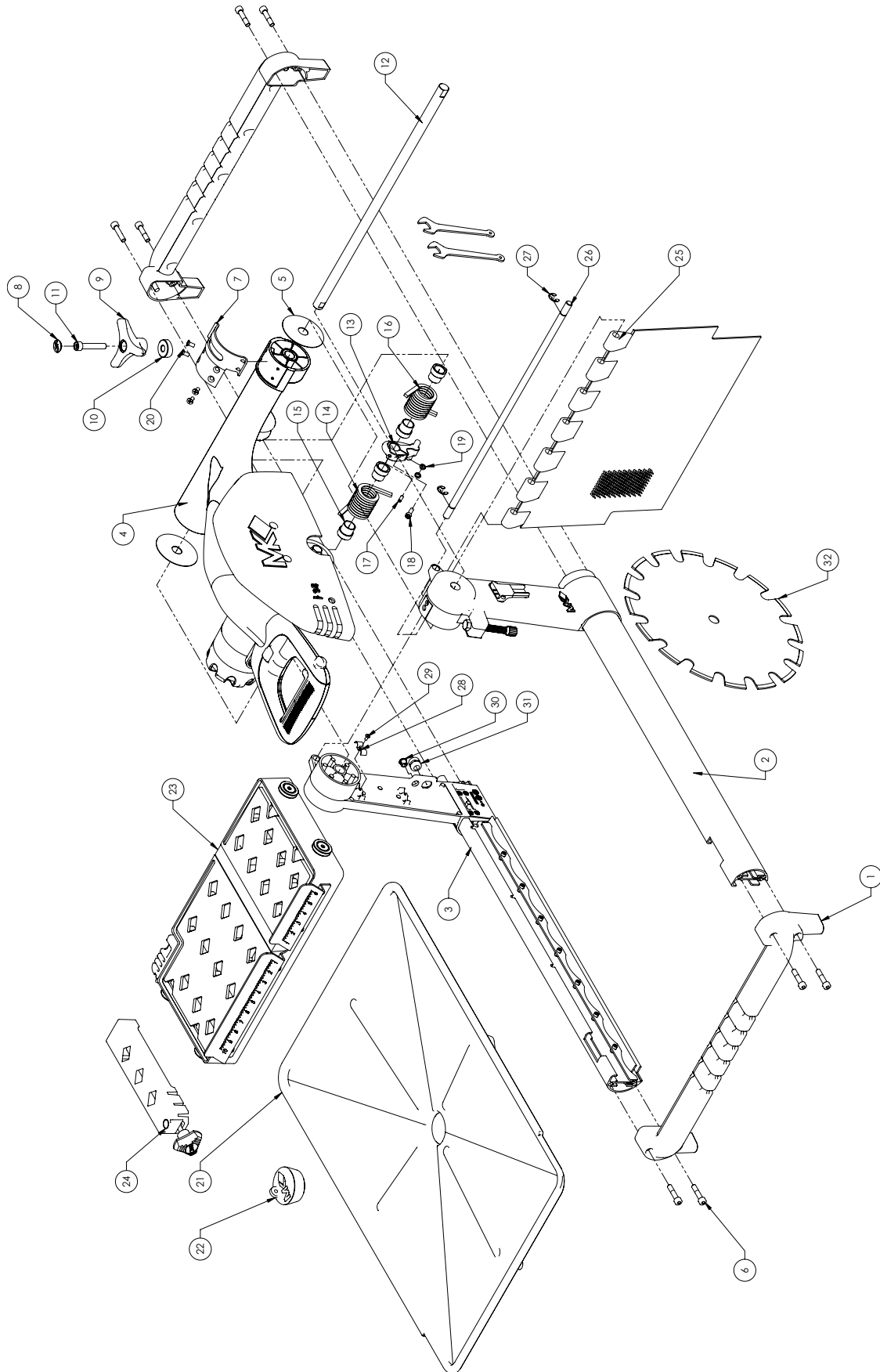

PART LIST, ASSEMBLY, FINAL

| ITEM NO. | PART NUMBER | DESCRIPTION | QTY. |
|----------|-------------|-------------------------------------|------|
| 1 | 166231 | ASSY, END CAP | 2 |
| 2 | 166234 | ASSY, RIGHT FRAME | 1 |
| 3 | 166235 | ASSY, LEFT FRAME | 1 |
| 4 | 166238 | ASSY, CUTTING HEAD | 1 |
| 5 | 164675 | RING, WEAR | 2 |
| 6 | 164721 | SCREW, SOC HD CAP, M8x30mm | 8 |
| 7 | 164712 | INDICATOR, DEPTH | 1 |
| 8 | 166311 | COVER, KNOB | 1 |
| 9 | 166312 | KNOB, TRI | 1 |
| 10 | 164727 | BUSHING, LOCK | 1 |
| 11 | 164773 | SCREW, SOC HD CAP TAPPING, M10x56mm | 1 |
| 12 | 164658 | SHAFT, PIVOT | 1 |
| 13 | 166313 | RETAINER, SPRING | 1 |
| 14 | 164660 | SPRING, TORSION, LH | 1 |
| 15 | 164661 | SPACER, SPRING | 4 |
| 16 | 164762 | SPRING, TORSION, RH | 1 |
| 17 | 164787 | SCREW, SOC SET, M5x16mm | 1 |
| 18 | 164775 | SCREW, SOC HD CAP, M6x25mm | 1 |
| 19 | 164803 | WASHER, FLAT, M7 | 2 |
| 20 | 164789 | SCREW, FLAT HD PHIL, M6x13mm | 4 |
| 21 | 164634 | PAN, WATER | 1 |
| 22 | 159858 | PLUG, DRAIN | 1 |
| 23 | 166233 | ASSY, TABLE | 1 |
| 24 | 166230 | ASSY, RIP GUIDE | 1 |
| 25 | 164769 | CURTAIN, SPLASH | 1 |
| 26 | 164665 | ROD CURTAIN | 1 |
| 27 | 164798 | RING, E-RETAINING, 10mm | 2 |
| 28 | 164724 | CLAMP, TWIN | 1 |
| 29 | 164776 | SCREW, PAN HD PHIL, M4x8mm | 1 |
| 30 | 164726 | BUSHING, SNAP | 1 |
| 31 | 164725 | BUSHING, STRAIN RELIEF | 1 |
| 32 | 157957-BK | BLADE | 1 |

ASSEMBLY, CUTTING HEAD

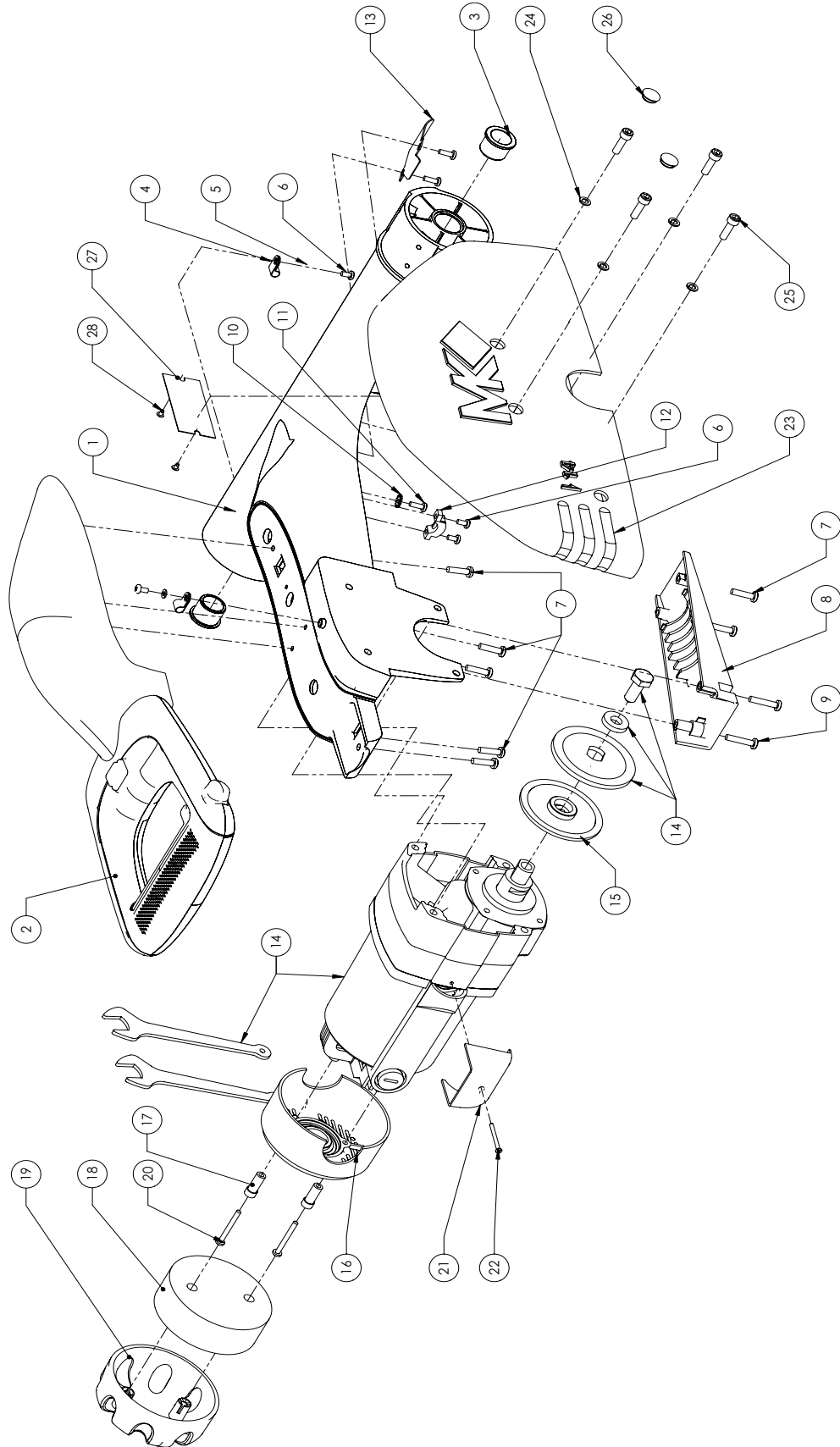

PART LIST, ASSEMBLY, CUTTING HEAD (P# 166238)

| ITEM NO. | PART NUMBER | DESCRIPTION | QTY. |
|----------|-------------|--|------|
| 1 | 164673 | ARM | 1 |
| 2 | 166237 | ASSY, HANDLE | 1 |
| 3 | 164674 | BUSHING, ARM | 2 |
| 4 | 164698 | CLAMP, TUBE | 2 |
| 5 | 164795 | WASHER, FLAT, M4 | 2 |
| 6 | 164776 | SCREW, PAN HD PHIL, M4x8mm | 4 |
| 7 | 164792 | SCREW, PAN HD PHIL, M5x20mm | 7 |
| 8 | 164680 | COVER, PUMP | 1 |
| 9 | 164781 | SCREW, PAN HD PHIL, M5x25mm | 2 |
| 10 | 164797 | WASHER, TOOTH LOCK EXT, M4 | 1 |
| 11 | 164778 | SCREW, PAN HD PHIL, M4x12mm | 3 |
| 12 | 164759 | CLAMP, CABLE | 1 |
| 13 | 166314 | SHIELD, POWER CORD | 1 |
| 14 | 166232 | MOTOR & ACCESSORIES | 1 |
| 15 | 158106 | FLANGE, INNER | 1 |
| 16 | 157877 | CAP, MOTOR | 1 |
| 17 | 157879 | SPACER, FILTER | 2 |
| 18 | 157729 | FILTER | 1 |
| 19 | 157878 | CAP, FILTER | 1 |
| 20 | 158157 | SCREW, PAN HD COMB SELF TAPPING, #8x1-1/2" | 2 |
| 21 | 157880 | COVER, WIRE | 1 |
| 22 | 158160 | SCREW, FLAT HD PHIL, #6x1-1/2" | 1 |
| 23 | 164681 | GUARD, BLADE | 1 |
| 24 | 166249 | WASHER, LOCK, M6 | 4 |
| 25 | 164775 | SCREW, SOC HD CAP, M6x25mm | 4 |
| 26 | 164685 | PLUG, SCREW HOLE | 2 |
| 27 | 157500 | TAG, SERIAL | 1 |
| 28 | 157849 | PIN, DRIVE, #7x5/16 | 2 |

PARTS & LIST <CON'T>

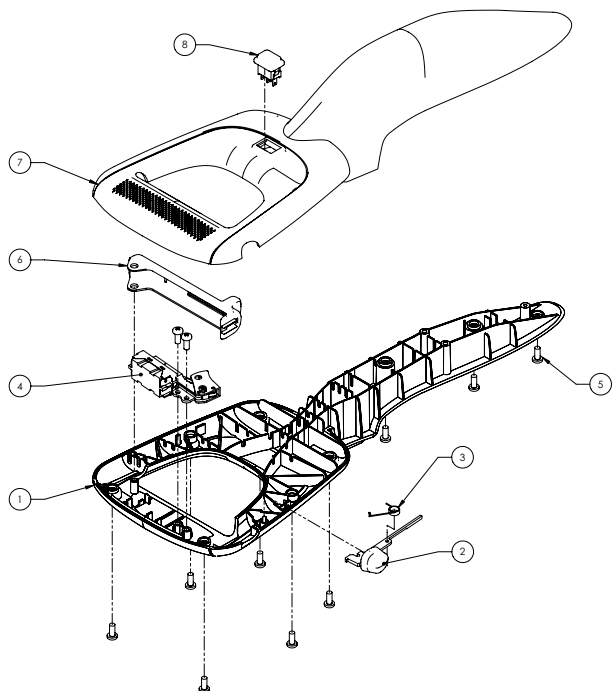

ASSY, HANDLE (P#166237)

| ITEM NO. | PART NUMBER | DESCRIPTION | QTY. |
|----------|-------------|-----------------------------------|------|
| 1 | 164667 | HANDLE, LOWER | 1 |
| 2 | 164671 | BUTTON, LOCK | 1 |
| 3 | 164734 | SPRING, RETURN | 1 |
| 4 | 164832 | SWITCH, TRIGGER | 1 |
| 5 | 164791 | SCREW, PAN HD, SELF TP, #10 x 1/2 | 11 |
| 6 | 164670 | LEVER, SWITCH | 1 |
| 7 | 164668 | HANDLE, UPPER | 1 |
| 8 | 166315 | SWITCH, PUMP | 1 |

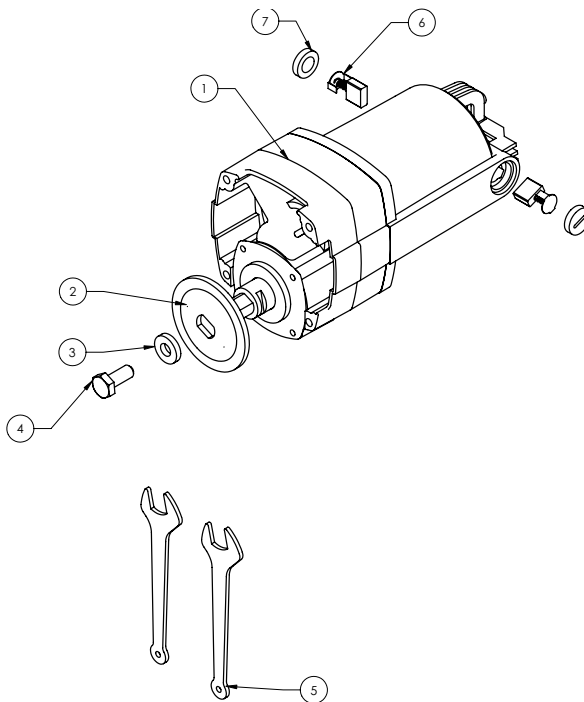

MOTOR & ACCESSORIES (P#166232)

| ITEM NO. | PART NUMBER | DESCRIPTION | QTY. |
|----------|-------------|-----------------------------|------|
| 1 | 157801-r | MOTOR | 1 |
| 2 | 158105 | FLANGE, INNER | 1 |
| 3 | 166134 | WASHER, M10 | 1 |
| 4 | 152272 | SCREW, HEX HD CAP, M10x20mm | 1 |
| 5 | 153450 | WRENCH, 17mm | 2 |
| 6 | 166228 | BRUSH, MOTOR | 2 |
| 7 | 166229 | CAP, MOTOR BRUSH | 2 |

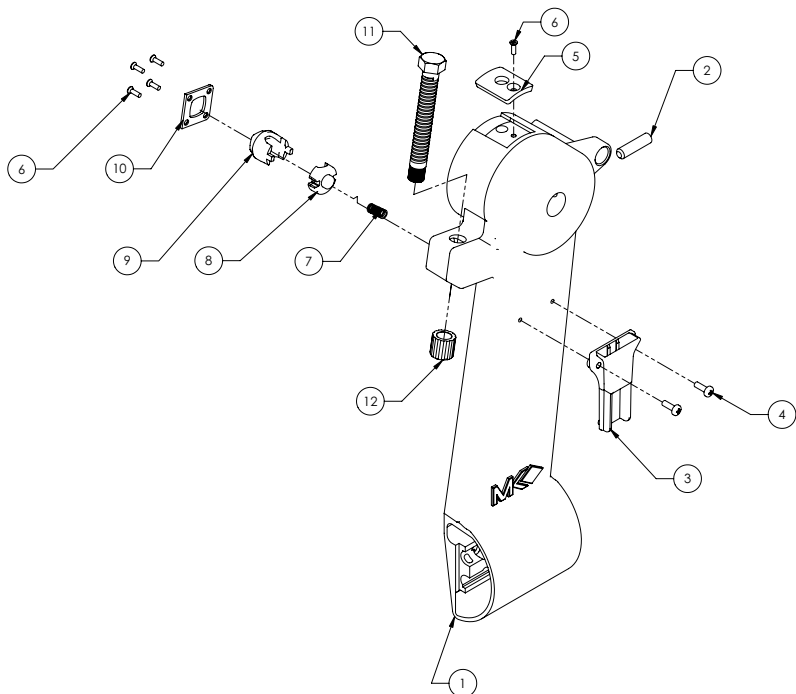

ASSY, VERTICAL SUPPORT, RIGHT (P#166236)

| ITEM NO. | PART NUMBER | DESCRIPTION | QTY. |
|----------|-------------|------------------------------|------|
| 1 | 166227 | SUPPORT, RIGHT VERTICAL | 1 |
| 2 | 164788 | SCREW, SOC SET, M8x30mm | 1 |
| 3 | 164669 | HOLDER, WRENCH | 1 |
| 4 | 164778 | SCREW, PAN HD PHIL, M4x12mm | 2 |
| 5 | 164723 | PLATE, LOCKING, CUTTING HEAD | 1 |
| 6 | 164784 | SCREW, FLAT HD PHIL, M4x10mm | 5 |
| 7 | 164717 | SPRING, RELEASE | 1 |
| 8 | 166316 | SEAT SPRING | 1 |
| 9 | 164718 | BUTTON, RELEASE | 1 |
| 10 | 164716 | COVER, RELEASE BUTTON | 1 |
| 11 | 164713 | STOP, DEPTH | 1 |
| 12 | 164714 | CAP, DEPTH STOP | 1 |

ASSEMBLY THE WHOLE FRAME & PART LIST

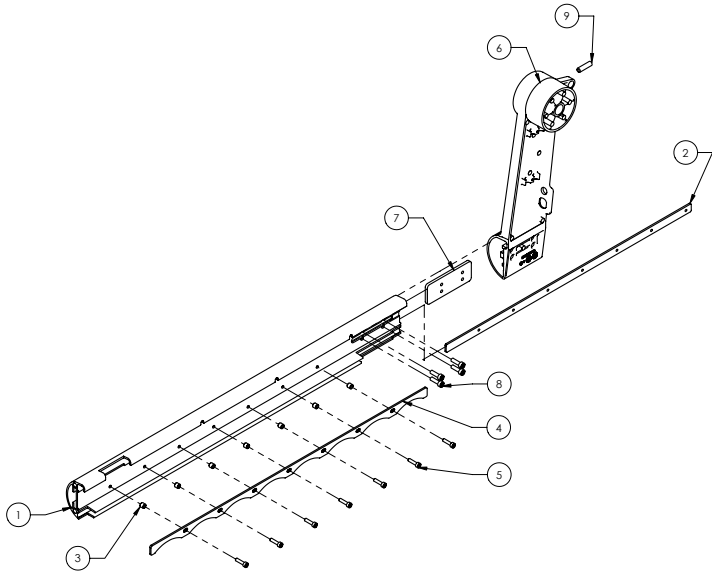

ASSY, LEFT FRAME (P#166235)

| ITEM NO. | PART NUMBER | DESCRIPTION | QTY. |
|----------|-------------|----------------------------|------|
| 1 | 164649 | FRAME, LEFT | 1 |
| 2 | 164722 | PLATE, RAIL SUPPORT | 1 |
| 3 | 164651 | STANDOFF, RAIL | 7 |
| 4 | 164650 | RAIL, STEEL | 1 |
| 5 | 164774 | SCREW, SOC HD CAP, M5x20mm | 7 |
| 6 | 164655 | SUPPORT, LEFT VERTICAL | 1 |
| 7 | 164657 | PLATE, RAIL SUPPORT | 1 |
| 8 | 164775 | SCREW, SOC HD CAP, M6x25mm | 4 |
| 9 | 164788 | SCREW, SOC SET, M8x30mm | 1 |

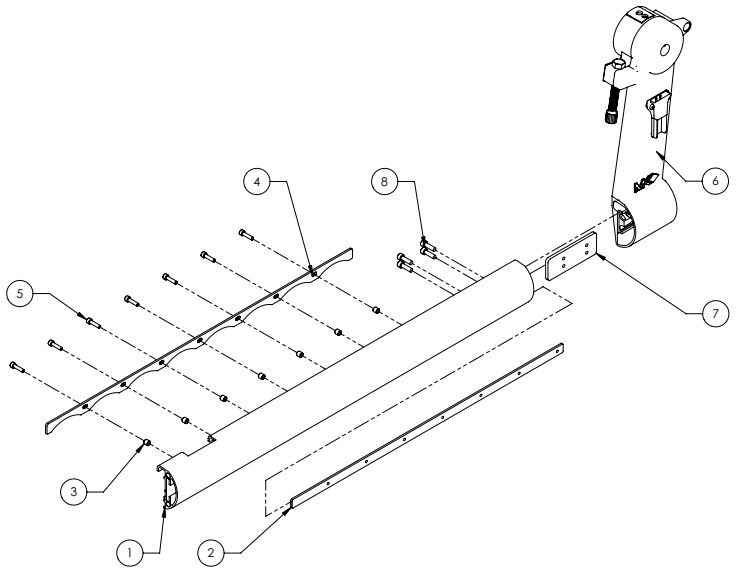

ASSY, RIGHT FRAME (P#166234)

| ITEM NO. | PART NUMBER | DESCRIPTION | QTY. |
|----------|-------------|-------------------------------|------|
| 1 | 164648 | FRAME, RIGHT | 1 |
| 2 | 164722 | PLATE, RAIL SUPPORT | 1 |
| 3 | 164651 | STANDOFF, RAIL | 7 |
| 4 | 164650 | RAIL, STEEL | 1 |
| 5 | 164774 | SCREW, SOC HD CAP, M5x20mm | 7 |
| 6 | 166236 | ASSY, SUPPORT, RIGHT VERTICAL | 1 |
| 7 | 164657 | PLATE, RAIL SUPPORT | 1 |
| 8 | 164775 | SCREW, SOC HD CAP, M6x25mm | 4 |

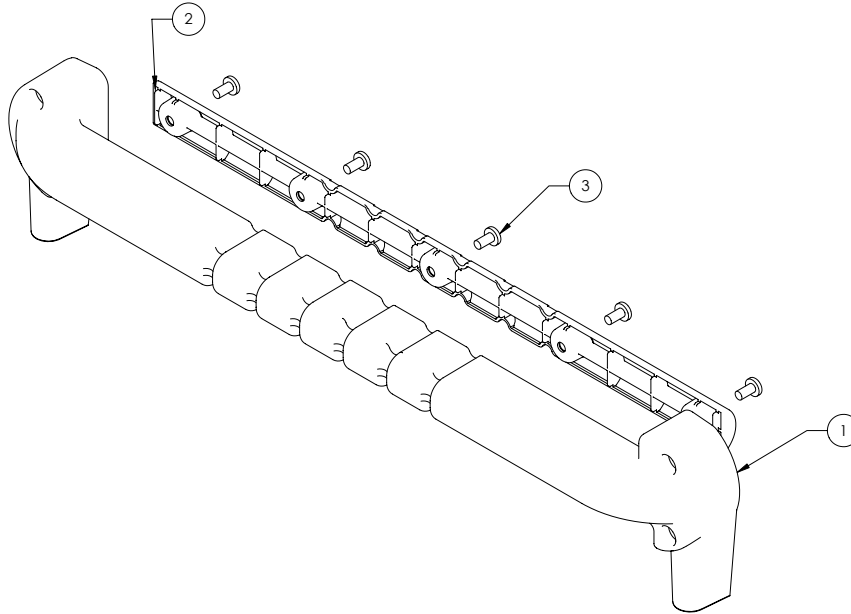

ASSY, END CAP (P#166231)

| ITEM NO. | PART NUMBER | DESCRIPTION | QTY. |
|----------|-------------|-----------------------------|------|
| 1 | 164652 | END CAP | 1 |
| 2 | 164653 | COVER, END CAP | 1 |
| 3 | 164783 | SCREW, PAN HD PHIL, M6x12mm | 5 |

ASSEMBLY TABLE, TABLE LOCK & PART LIST

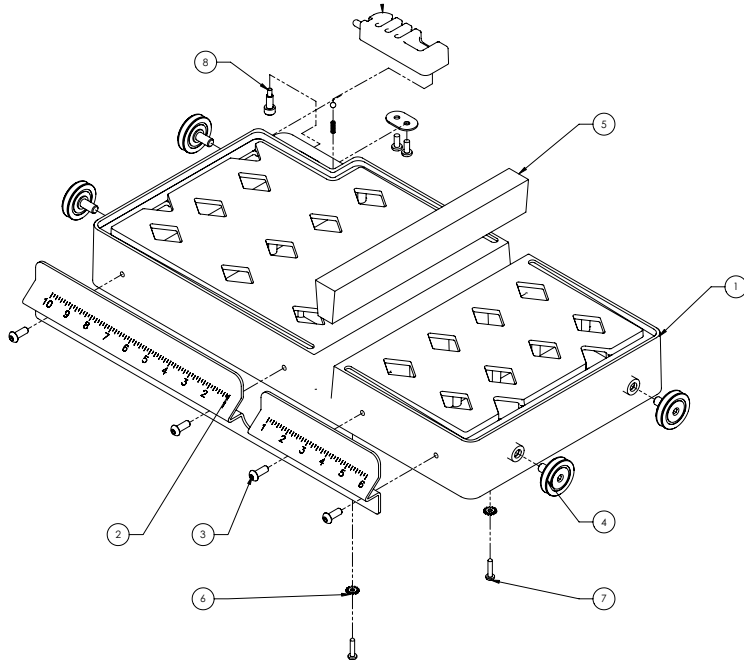

ASSY, TABLE (P#166233)

| ITEM NO. | PART NUMBER | DESCRIPTION | QTY. |
|----------|-------------|-----------------------------|------|
| 1 | 164636 | TABLE | 1 |
| 2 | 164637 | FENCE, TABE | 1 |
| 3 | 164772 | SCREW, PAN HD PHIL, M6x16mm | 4 |
| 4 | 133090 | WHEEL, ROLLER | 4 |
| 5 | 164641 | STRIP, WOOD | 1 |
| 6 | 164797 | WASHER, TOOTH LOCK EXT, M4 | 2 |
| 7 | 164796 | SCREW, WOOD, M4x20mm | 2 |
| 8 | 164760 | PIN, GUIDE | 1 |
| 9 | 166239 | KIT, TABLE LOCK | 1 |

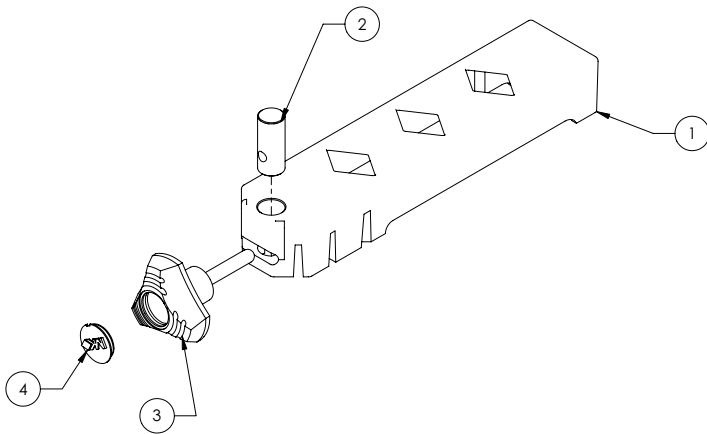

ASSY, RIP GUIDE (P#166230)

| ITEM NO. | PART NUMBER | DESCRIPTION | QTY. |
|----------|-------------|-------------|------|
| 1 | 164645 | GUIDE, RIP | 1 |
| 2 | 164646 | PIN, SWIVEL | 1 |
| 3 | 164659 | KNOB | 1 |
| 4 | 164728 | COVER, KNOB | 1 |

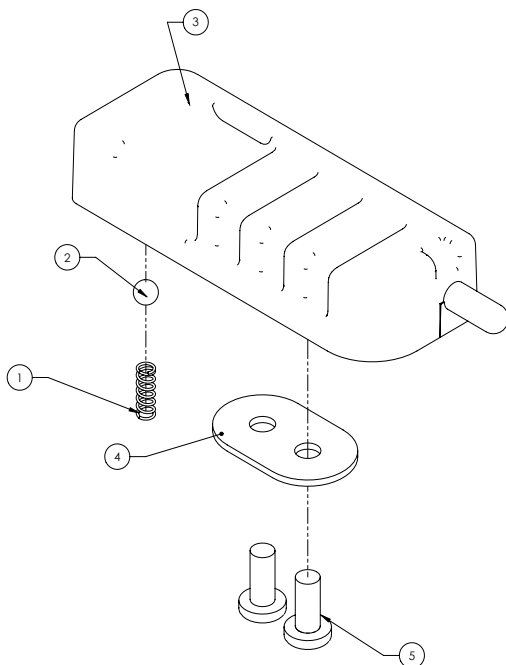

KIT, TABLE LOCK (P#166239)

| ITEM NO. | PART NUMBER | DESCRIPTION | QTY. |
|----------|-------------|-----------------------------|------|
| 1 | 164644 | SPRING, TABLE LOCK | 1 |
| 2 | 164643 | BALL, STEEL, 5mm | 1 |
| 3 | 164642 | LOCK, TABLE | 1 |
| 4 | 164719 | WASHER, DOUBLE HOLE | 1 |
| 5 | 164791 | SCREW, PAN HD PHIL, M5x12mm | 2 |

ASSEMBLY MISTING SYSTEM & PART LIST

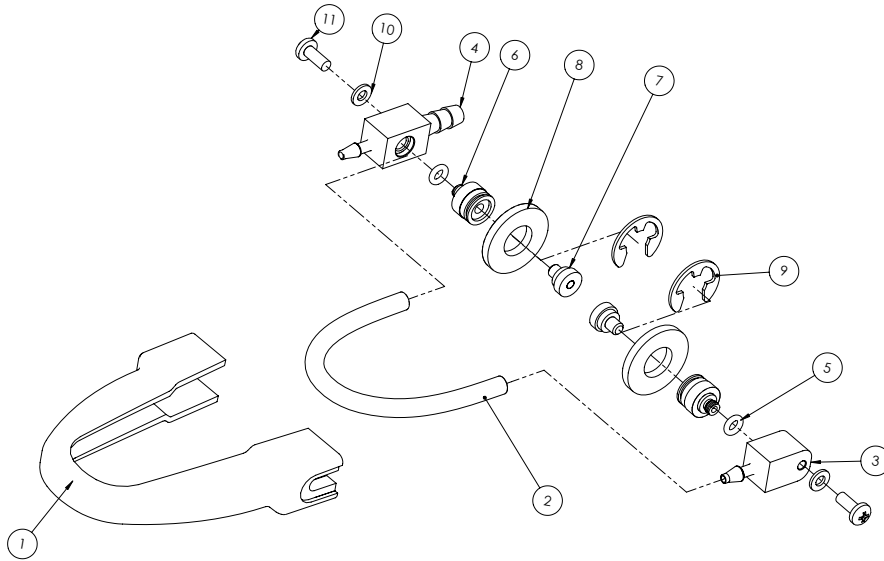

MODULE, MISTING (P#166240)

| ITEM NO. | PART NUMBER | DESCRIPTION | QTY. | | VENDOR PART NUMBER |
|----------|-------------|-----------------------------|------|--|--------------------|
| 1 | 164703 | COVER, PLASTIC TUBE | 1 | | 260515000 |
| 2 | 164704 | TUBING, PVC, 1/4x3/16x3.55" | 1 | | 260516000 |
| 3 | 164702 | FITTING, SHORT | 1 | | 260513000 |
| 4 | 164701 | FITTING, LONG | 1 | | 260514000 |
| 5 | 165009 | O-RING, 7.8x1.9mm | 2 | | A63000000040 |
| 6 | 164700 | ADAPTER, NOZZLE | 2 | | 260512100 |
| 7 | 164699-100 | NOZZLE, 1mm, 10-24 Thread | 2 | | 260510000 |
| 8 | 166194 | WASHER, RUBBER, 26x12x3mm | 2 | | 260536000 |
| 9 | 166195 | RING, E-RETAINING, 9mm | 2 | | A47000090000 |
| 10 | 165007 | WASHER, FLAT, M4 | 2 | | A35010410010 |
| 11 | 165006 | SCREW, PAN HD PHIL, M4x8mm | 2 | | A10001040100 |

ASSEMBLY MISTING SYSTEM WATER TANK & PART LIST

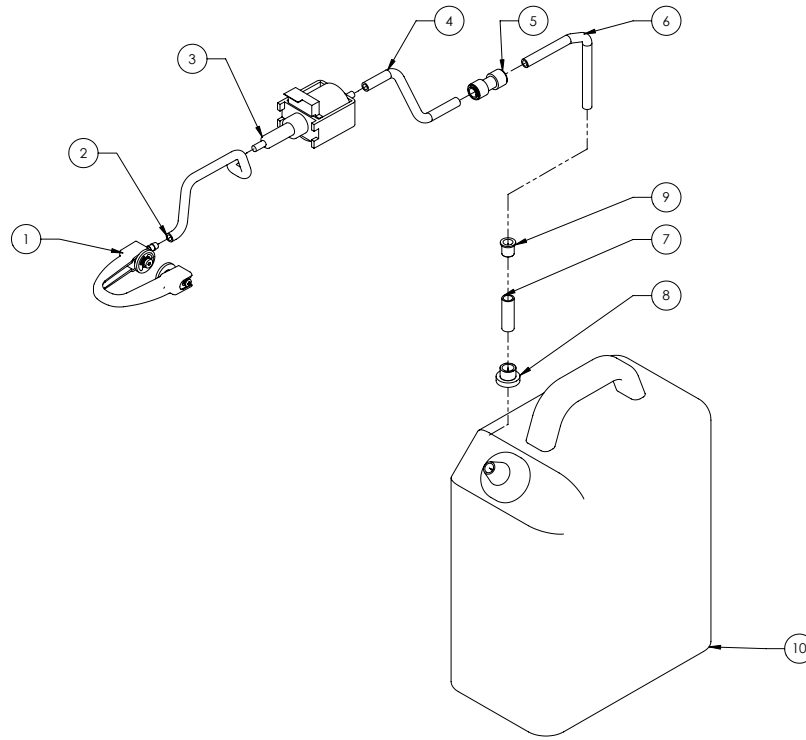

KIT, MISTING (P#165013-MK)

| ITEM NO. | PART NUMBER | DESCRIPTION | QTY. |
|----------|-------------|------------------------------------|------|
| 1 | 166240 | MODULE, MISTING | 1 |
| 2 | 165008 | TUBING, POLYURETHANE, 3/8x.245x19 | 1 |
| 3 | 164693 | PUMP | 1 |
| 4 | 165005 | TUBING, POLYURETHANE, 3/8x.245x24 | 1 |
| 5 | 165004 | COUPLING, PUSH-TO-CONNECT, 3/8x3/8 | 1 |
| 6 | 164692 | TUBING, PVC, 3/8x1/4x51" | 1 |
| 7 | 165001 | TUBING, PVC, 1/2x3/8x1-1/2 | 1 |
| 8 | 164691 | FILTER | 1 |
| 9 | 165003 | GROMMET | 1 |
| 10 | 165002 | CONTAINER, WATER | 1 |
| 11 | 165011 | INSTRUCTION SHEET (NOT SHOWN) | 1 |
| 12 | 152566 | CARTON, OUTER (NOT SHOWN) | 1 |

THEORY

THEORY OF DIAMOND BLADES

Diamond blades do not really cut; they grind the material through friction. Diamond crystals, often visible at the leading edge and sides of the rim/segment, remove material by scratching out particles of hard, dense materials, or by knocking out larger particles of loosely bonded abrasive material. This process eventually cracks or fractures the diamond particle, breaking it down into smaller pieces. As a result, a diamond blade for cutting soft, abrasive material must have a hard metal matrix composition to resist this erosion long enough for the exposed diamonds to be properly utilized. Conversely, a blade for cutting a hard, non-abrasive material must have a soft bond to ensure that it will erode and expose the diamonds embedded in the matrix. These simple principles are the foundation of “controlled bond erosion”.

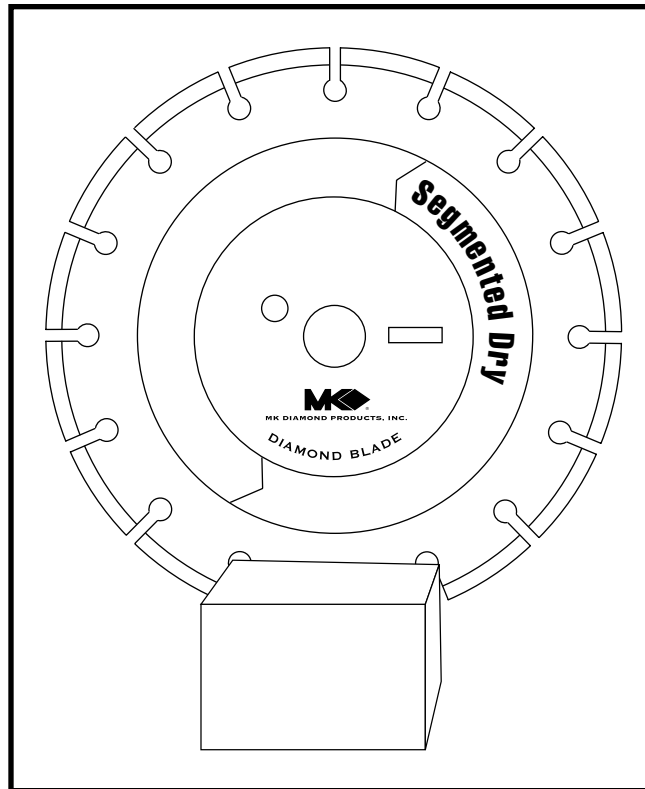

TYPES OF CUTTING:

There are two basic types of cutting-Dry or Wet. The choice of which type of blade to use depends on:

- The requirements of the job
- The machine/tool utilizing the diamond blade
- The preference of the operator



In the case of DRY cutting, the overwhelming popularity and quantity of hand-held saws and the flexible nature of MK Diamond blades to professionally handle most ceramic, masonry, stone and concrete materials, make the DRY cutting blade a very attractive tool. When using a DRY blade, the user must be aware of distinct operating practices to ensure optimum performance. DRY cutting blades require sufficient airflow about the blade to prevent overheating of the steel core. This is best accomplished by shallow, intermittent cuts of the material with periods of “free-spinning” (for several seconds) between each cut, to maximize the cooling process.

For WET cutting applications, MK has the exact blade to compliment both the material to be cut and the wet cutting machine to be used. During cutting operations, liberal amounts of water act as a coolant to support the cutting effectiveness and longevity of the WET blade. Additionally, using water adds to the overall safety of cutting operations by keeping the dust signature down.

Know All You Can About the Material You Wish to Cut.

ACCESSORIES, ORDERING & RETURN INFORMATION

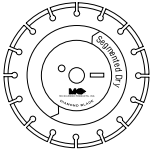
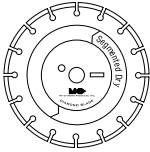
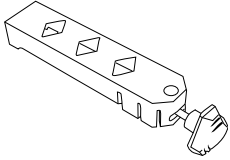
ACCESSORIES:

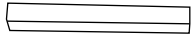
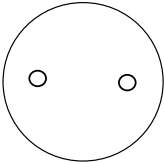
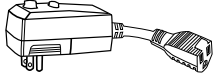
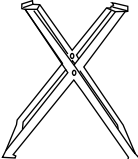
| ITEM | NUMBER | DESCRIPTION | |
|------|--------|--|---|
| 1. | 157957 | MK-BX10, Dry Cutting 14" Segmented Blade |  |
| 2. | 157944 | MK-BX30, Dry Cutting 14" Segmented Block Blade |  |
| 3. | 231276 | Adjustable Cutting Guide |  |
| 4. | 133090 | Roller Wheel |  |
| 5. | 156427 | Protective Wooden Strip |  |
| 6. | 157729 | Motor Air Filter |  |
| 7. | 152610 | Ground Fault Circuit Interrupter |  |
| 8. | 162771 | BX-4 Stand (Stand contains Owner's Manual) |  |

ACCESSORIES, ORDERING & RETURN INFORMATION

ORDERING INFORMATION:

You may order MK Diamond products through your local MK Diamond distributor or, you may order direct from MK Diamond.

NOTE: There is a \$25.00 minimum order when ordering direct from MK Diamond. All purchases must be made using VISA or MasterCard.

When ordering direct from MK Diamond, please have the following information ready before calling:

- The Model Number of the saw
- The Serial Number of the saw
- Where the saw was purchased and when
- The Part Number for the part(s) being ordered
- The Part Description for the part(s) being ordered

All parts may be ordered by calling toll free to – **800 421-5830** or **310 539-5221** and asking for Customer Service. For technical questions, call – **800 474-5594**.

RETURN MATERIALS POLICY:

To expedite the service relative to the return of a product purchased through MK Diamond, please observe the following:

NOTE: When returning all items, they must have been purchased within the previous twelve (12) months.

- Have the Model Number of the saw
- Have the Serial Number of the saw
- Have the location of where the saw was purchased
- Have the date when the saw was purchased
- Contact Customer Service for approval to return the item(s)
- Obtain a Returned Goods Number (RGA) authorizing the return
- Follow the packaging instructions in the following section
- Ensure your item(s) are prepaid to the destination

For returned items, call toll free to – **800 421-5830** or **310 539-5221** and ask for Customer Service. For technical questions, call – **800 474-5594** or **310 257-2845**.

PACKAGING INSTRUCTIONS:

- Remove the Blade guard and Support Angle Assembly
- Dry the saw before shipping
- When packing, include the following: BX-4, Diamond Blade, Movable Cutting Table and Adjustable Cutting Guide (Other Accessories are not required)
- Package the unit in its original container or one of comparable size (do not ship the unit partially exposed)
- Ensure all parts are secured in the packaging to prevent moving

AUTHORIZED SERVICE CENTERS:

For quicker repair time, you may contact MK Diamond Customer Service, toll free, at – **800 421-5830** or **310 539-5221** for the Authorized Service Center closest to you. For technical questions, call – **800 474-5594**.

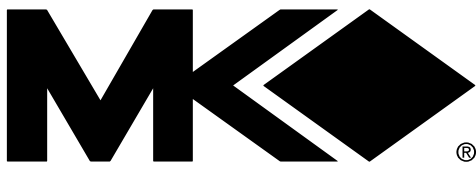

BX-4

BRICK SAW WITH MISTING DUST CONTROL

OWNER'S MANUAL & OPERATING INSTRUCTIONS

CALIFORNIA PROPOSITION 65 MESSAGE:

WARNING

Some dust created by power sanding, sawing, grinding, drilling, and other construction activities contain chemicals known [to the State of California] to cause cancer, birth defects or other reproductive harm.

Some examples of these chemicals are:

- Lead, from lead-based paints
- Crystalline silica, from bricks and cement and other masonry products and
- Arsenic and chromium, from chemically treated lumber

Your risk from these exposures varies depending on how often you do this type of work. To reduce your exposure to these chemicals, work in a well-ventilated area, and work with approved safety equipment, such as those dust masks that are specially designed to filter out microscopic particles.

MK DIAMOND PRODUCTS, INC.
1315 STORM PARKWAY
TORRANCE, CA 90509-2803
(310) 257-2845