

MK-EZ PROFILER

OWNER'S MANUAL, PARTS LIST & OPERATING INSTRUCTIONS



Revision 100	12.2013
Manual Part No. 170565-OM	

Caution: Read all safety and operating instructions before using this equipment. This owners manual **MUST** accompany the equipment at all times.

INTRODUCTION

Congratulations on your purchase of a MK-EZ Profiler. We are certain that you will be pleased with your purchase. MK Diamond takes pride in producing the finest construction power tools and diamond blades in the industry.

Operated correctly, your MK-EZ Profiler should provide you with years of service. In order to help you, we have included this manual. This owners manual contains information necessary to operate and maintain your MK-EZ Profiler safely and correctly. Please take a few minutes to familiarize yourself with the MK-EZ Profiler by reading and reviewing this manual.

If you should have questions concerning your MK-EZ Profiler, please feel free to call our friendly customer service department at: 800 421-5830

Regards,

MK Diamond

NOTE THIS INFORMATION FOR FUTURE USE:

MODEL NUMBER:	
SERIAL NUMBER:	
PURCHASE PLACE:	
PURCHASE DATE:	

NOTE: For your (1) one year warranty to be effective, complete the warranty card (including the Serial Number) and mail it in as soon as possible.

TABLE OF CONTENTS

SAFETY

Safety Messages	4
Damage Prevention Message	4
General Safety Precautions	4-7
California Proposition 65 Message	8
Electrical Requirements	9-12
Safety Label Locations	14
Product Specifications	15

UNPACKING, TRANSPORT and ASSEMBLY

Unpacking	16
Contents	16
Transport	16

STARTUP, ADJUSTMENT, OPERATION and SHUTDOWN

Water Pump Installation	17
Cutting Head Installation	17-18
Profile Tool Installation	18
Fence Installation	19
Profile Adjustment	20
Connecting the water	20
Water Setup	21
Pre-Start inspection	21
Water Nozzle Adjustment	22
Profiling	22

EXPLODED VIEW AND PARTS LIST

Exploded View & Parts List	24-30
----------------------------	-------

ACCESSORIES

Accessories	32
-------------	----

ORDERING and RETURN INSTRUCTIONS

Ordering Information	34
Return Material Policy	34
Packaging Instructions	34
Authorized Service Centers	35
Contact & Warranty	35

Read and follow all safety, operating and maintenance instructions. Failure to read and follow these instructions could result in injury or death to you or others. Failure to read and follow these instructions could also result in damage and/or reduced equipment life. Safety warnings and guidelines do not by themselves eliminate danger. They are not substitutes for proper accident prevention procedures and good judgement.

SAFETY MESSAGES

A safety message alerts you to potential hazards that could hurt you or others. Each safety message is preceded by a safety alert symbol () and one of three words: **DANGER**, **WARNING**, or **CAUTION**.



DANGER You **WILL** be **KILLED** or **SERIOUSLY INJURED** if you **DO NOT** follow directions.



WARNING You **CAN** be **KILLED** or **SERIOUSLY INJURED** if you **DO NOT** follow directions.



CAUTION You **CAN** be **INJURED** if you **DO NOT** follow directions. It may also be used to alert against unsafe practices.

DAMAGE PREVENTION AND INFORMATION MESSAGES

A Damage Prevention Message is to inform the user of important information and/or instructions that could lead to equipment or other property damage if not followed. Information Messages convey information that pertains to the equipment being used. Each message will be preceded by the word **NOTE**, as in the example below.

NOTE: Equipment and/or property damage may result if these instructions are not followed.

GENERAL SAFETY PRECAUTIONS AND HAZARD SYMBOLS

In order to prevent injury, the following safety precautions and symbols should be followed at all times!

SAFETY PRECAUTIONS



ALWAYS read this Owner's Manual before operating the machine. **DO NOT** operate or service this equipment before reading this entire manual. Read and understand all warnings, instructions and controls on the machine. Know how to stop the equipment quickly in case of emergency. It is the operators responsibility to use this machine under safe working conditions and conform with federal, state and local codes or regulations pertaining to safety, air, pollution, noise etc...



ALWAYS keep the Blade and Belt Guards in place. **DO NOT** operate this machine with any guard or safety device removed. A Guard, or any damaged part should be repaired or replaced immediately.

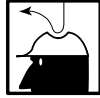

NEVER operate this equipment without proper protective clothing, shatterproof glasses, steel-toed boots and other protective devices required by the job. Non-slip foot wear is recommended.

**PERSONAL PROTECTIVE EQUIPMENT**

ALWAYS wear approved respiratory, head, ear and eye protection when operating this machine.

**ACCIDENTAL STARTS!**

Before starting the engine/motor, be sure the **ON/OFF** switch is in the **OFF** position to prevent accidental starting. Place the **ON/OFF** switch in the **OFF** position before performing any service operation. **ALWAYS** place the power **ON/OFF** switch in the **OFF** position when the machine is not in use.

**ROTATING PARTS**

Keep hands, feet, hair, and clothing away from all moving parts to prevent injury. Never operate the motor with covers, shrouds, or guards, removed.

**HOT PARTS!**

Engine components can become extremely hot from operation. To prevent severe burns, do not touch these areas while the engine is running, or immediately after it is turned off. Never operate the engine with heat shields removed.

**OVER SPEED**

NEVER tamper with the governor components or settings to increase the maximum speed. Severe personal injury and damage to the engine or equipment can result if operated at speeds above maximum.

**ELECTRICAL SHOCK**

NEVER touch electrical wires or components while the engine is running. Exposed, frayed or worn electrical wiring and plugs can be sources of electrical shock which could cause severe injury or burns. Do not touch the plug with wet hands.



ALWAYS avoid inhalation of and skin contact with silica dust and/or mist. Provide proper dust removal. Use dust-collection system when applicable.



NEVER operate the machine in an explosive atmosphere or near combustible materials. Sparks from the cutting-action of this machine can ignite flammable materials, liquids, gases or dust.



This equipment should not be operated by persons under 18 years of age.

**KEEP CHILDREN AWAY**

All visitors and children should be kept a safe distance from work area. Maintain a safe operating distance to other personnel.

**MAKE THE WORKSHOP KID PROOF**

Make the workshops kid proof by using padlocks, master switches or by removing starter keys.

**DO NOT FORCE THE TOOL**

A power tool will do a job better and safer operating at the rate for which it was designed. **DO NOT** force a tool or an attachment to do a job that it was not designed to do.

**USE PROPER APPAREL**

DO NOT wear loose clothing, gloves, neckties, rings, bracelets, or other jewelry that may be caught in moving parts. Non-slip footwear is recommended. Wear protective hair covering to contain long hair.

**SECURE WORK**

Clamps or a vise should be used to hold work whenever practical. Keeping your hands free to operate a power tool is safer.

**DO NOT OVERREACH**

Keep proper footing and balance at all times by not overreaching.

**DISCONNECT TOOLS**

Power tools should always be disconnected before servicing, adjusting or when changing accessories, such as blades, bits, cutters, and the like.

**MAINTAIN TOOLS WITH CARE**

Keep tools clean and maintained for the best and safest performance. Always follow maintenance instructions and examine the machine before use. If any abnormal vibrations or noises occurs, turn off machine immediately and have the problem corrected before further use.

**REMOVE ADJUSTING KEYS AND WRENCHES**

Form a habit of checking to see that keys and adjusting wrenches are removed from the power tool before it is turned on.

**KEEP WORK AREA CLEAN**

Cluttered work areas and benches invite accidents. Keep area around machine clear of obstructions which could cause persons to fall.

**DO NOT USE IN DANGEROUS PLACES**

DO NOT operate equipment in dangerous or hazardous environments. **DO NOT** use power tools in damp or wet locations nor expose them to rain. Always keep the work area well lighted.

**USE RECOMMENDED ACCESSORIES**

Consult the owner's manual for recommended accessories. Using improper accessories may increase the risk of personal or by-stander injury. Unauthorized equipment modifications will void all warranties. Manufacturer does not assume responsibility for any accident due to equipment modifications.



ALWAYS ensure that the machine is on level ground before using.

**NEVER STAND ON THE TOOL**

Serious injury could occur if a power tool is tipped, or if a cutting tool is unintentionally contacted.

**TRANSPORT**

When loading or unloading the machine, use caution. Remove the blade prior to hoisting, loading and transporting the machine.

**CHECK FOR DAMAGED PARTS**

Before using a power tool, check for damaged parts. A guard or any other part that is damaged should be carefully checked to determine if it would operate properly and perform its intended function. Always check moving parts for proper alignment or binding. Check for broken parts and mountings and all other conditions that may affect the operation of the power tool. A guard, or any damaged part, should be properly repaired or replaced. Always check the machine for loose bolts before starting.

**DIRECTION OF ROTATION**

A blade or cutter should always be installed so that rotation is in the direction of the arrow imprinted on the side of the blade or cutter. It should correspond with the rotational direction of the motor. Always feed work into a blade against the direction of rotation.

**NEVER LEAVE A TOOL UNATTENDED**

TURN POWER OFF - Do not leave a tool until it comes to a complete stop. **ALWAYS** turn a power tool **OFF** when leaving the work area, or, when a cut is finished.



NEVER disconnect any "emergency or safety devices". These devices are intended for operator safety. Disconnection of these devices can cause severe injury, bodily harm, or even death! Disconnection of any of these devices will void all warranties. Unauthorized equipment modifications will void all warranties. Manufacturer does not assume responsibility for any accident due to equipment modifications.



NEVER use this machine with any cutter designed for woodworking.



NEVER operate this equipment when not feeling well due to fatigue, illness or taking medicine.



NEVER operate this equipment under the influence of drugs or alcohol.



On belt driven equipment, overtensioning of belts will result in premature crank and/or bearing failure.



Whenever necessary, replace nameplate, operation and safety decals when they become difficult to read.



ALWAYS store equipment properly when it is not being used. Equipment should be stored in a clean, dry location out of the reach of children



DO NOT lend or rent this equipment without including the Owner's Manual and the Engine/Motor Manufacturer's Manual.



Check the chemical properties of the material to be cut/grinded and follow all EPA/OSHA Regulations.

SILICA DUST WARNING

Grinding/cutting/drilling of masonry, concrete, metal and other materials with silica in their composition may give off dust or mists containing crystalline silica. Silica is a basic component of sand, quartz, brick clay, granite and numerous other minerals and rocks. Repeated and/or substantial inhalation of airborne crystalline silica can cause serious or fatal respiratory diseases, including silicosis. In addition, California and some other authorities have listed respirable crystalline silica as a substance known to cause cancer. When cutting such materials, always follow respiratory precautions.

Use appropriate NIOSH-approved respiratory protection where dust hazard may occur. Paper masks or surgical masks without a NIOSH approval number are not recommended because they do little to protect the worker. For more information about respirator programs, including what respirators have received NIOSH approval as safe and effective, please visit the NIOSH website at:
<http://www.cdc.gov/niosh/topics/respirators>

Observe OSHA regulations for respirator use (29 C.F.R. §1910.134).
Visit <http://www.osha.gov> for more information.

CALIFORNIA PROPOSITION 65 MESSAGE

Some dust created by power sanding, sawing, grinding, drilling, and other construction activities contain chemicals known (to the State of California) to cause cancer, birth defects or other reproductive harm. Some examples of these chemicals are:

- Lead, from lead-based paints
- Crystalline silica from bricks, cement and other masonry products
- Arsenic and chromium, from chemically treated lumber

For further information, consult the following sources:
<http://www.osha.gov/dsg/topics/silicacrystalline/index.html>
<http://www.cdc.gov/niosh/docs/96-112/>
<http://oehha.ca.gov/prop65/law/P65law72003.html>
<http://www.dir.ca.gov/Title8/sub4.html>

Your risk from these exposures varies depending on how often you do this type of work. To reduce your exposure to these chemicals, work in a well-ventilated area, and work with approved safety equipment, such as dust masks that are specially designed to filter out microscopic particles. Where use of a dust extraction device is possible, it should be used. To achieve a high level of dust collection, use an industrial HEPA vacuum cleaner. Observe OSHA 29 CFR part 1926.57 and 1926.103.



WARNING

Sawing, grinding and drilling generate dust. Excessive airborne particles may cause irritation to eyes, skin and respiratory tract. To avoid breathing impairment, always employ dust controls and protection suitable to the material being sawed or drilled; See OSHA (29 CFR Part 1910.1200).

ELECTRICAL REQUIREMENTS AND GROUNDING INSTRUCTIONS

In order to prevent electrical shock and injury, the following electrical safety precautions and symbols should be followed at all times!



WARNING

In case of a malfunction or breakdown, grounding provides a path of least resistance for electrical current to reduce the risk of electric shock. This tool is equipped with an electric cord which has an equipment-grounding conductor and a grounding plug. The plug must be plugged into a matching outlet that is properly installed and grounded in accordance with all local codes and ordinances.

- **DO NOT** modify the plug provided - if it will not fit the outlet, have the proper outlet installed by a qualified electrician.
- Improper connections of the equipment-grounding conductor can result in a risk of electric shock. The equipment-grounding conductor is the insulated conductor that has an outer surface that is green, with or without yellow stripes. If repair or replacement of the electric cord or plug is necessary, **DO NOT** connect the equipment-grounding conductor to a live terminal.
- Check with a qualified electrician or service personnel if the grounding instructions are not completely understood, or if in doubt as to whether the tool is properly grounded.
- Use only 3-wire extension cords that have 3-prong grounding plugs and 3-pole receptacles that accept the tool's plug.
- Repair or replace a damaged or worn cord immediately.

This tool is intended for use on a circuit that has an outlet that looks like the one shown in Sketch A. The tool has a grounding plug that looks like the plug illustrated in Sketch A. A temporary adapter, which looks like the adapter illustrated in sketches B and C, may be used to connect this plug to a 2-pole receptacle as shown in Sketch B, if a properly grounded outlet is not available. The temporary adapter should be used only until a properly grounded outlet can be installed by a qualified electrician. The green-colored rigid ear, plug, and the like, extending from the adapter, must be connected to a permanent ground, such as a properly grounded outlet box.

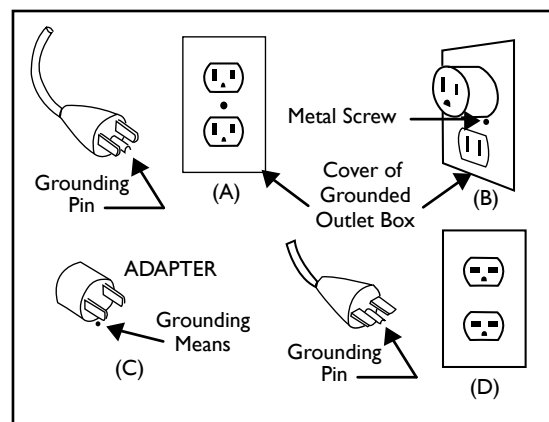

Circuit and Adapter Information

NOTE: Use of a temporary adapter is not permitted in Canada.

NOTE: If permanently connected this tool should be connected to a grounded metal permanent wiring system; or to a system having an equipment - grounding conductor.

ELECTRIC MOTOR SAFETY

For maintenance care and operation of the electric motor, refer to your electric motor instruction booklet furnished with the electric motor. Protect the electric motor from dust as much as possible and keep ventilating openings clean. Before plugging in the machine, make sure that the outlet voltage is within the voltage marked on the machines's data plate.



CAUTION



DO NOT spray water on the electric motor. **DO NOT** touch the plug with wet hands. To reduce the risk of electrocution, keep all connections dry and off the ground.



DO NOT operate electric motor in an explosive environment.



DO NOT EXPOSE TO RAIN

DO NOT expose to rain or use in damp locations.



WARNING



If operating the equipment in damp locations is unavoidable, **ALWAYS** use a Ground Fault Circuit Interrupter, **ALWAYS** wear rubber gloves and footwear in damp conditions.



DO NOT abuse the cord. Never use the cord to carry the equipment or to pull the plug from the outlet. Keep the cord away from heat, sharp edges, and moving parts. Replace damaged cords immediately. Damaged cords increase the risk of electric shock.



WARNING

To reduce the risk of electrocution, keep all connections dry and off the ground. A Ground Fault Circuit Interrupter (GFCI) should be provided on the circuit(s) or outlet(s) to be used for this machine. Receptacles are available having built-in GFCI protections and may be used for this measure of safety. When using an extension cord, GFCI should be installed closest to the power source, followed by the extension cord and lastly, the machine.



WARNING

The water pump requires a GFCI. To reduce risk of electrical shock when operating the machine with the pump plugged into the 3-pole receptacle on the motor, connect the machine to a GFCI outlet. See the pump manual and informational tags enclosed separately for all pump information.

**WARNING**

To avoid the possibility of the appliance or plug receptacle getting wet, position the machine to one side of a wall mounted receptacle. This will prevent water from dripping into the receptacle or plug. A "drip loop," shown in the picture below, should be arranged by the user to properly position the power cord relative to the power source. Use the drip loop as a way to prevent GFCI and plug from getting wet.

The "drip loop" is that part of the cord below the level of the receptacle (or the connector, if an extension cord is used). This method of positioning the cord prevents the travel of water along the power cord and coming in contact with the receptacle.

If the plug or receptacle gets wet, **DO NOT** unplug the cord. Disconnect the fuse or circuit breaker that supplies power to the tool. Then unplug and examine for presence of water in the receptacle.

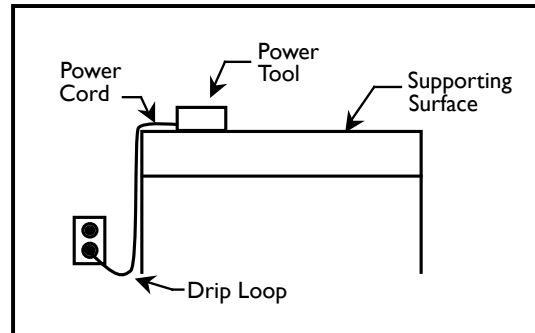

Drip Loop Information

**WARNING**

Use only extension cords that are intended for outdoor use. These extension cords are identified by a marking "Acceptable for use with outdoor appliances; store indoors while not in use." Use only extension cords having an electrical rating not less than the rating of the product. **DO NOT** use damaged extension cords. Examine extension cords before using and replace if damaged. **DO NOT** abuse extension cords and **DO NOT** yank on any cord to disconnect. Keep cords away from heat and sharp edges. Always disconnect the extension cord from the receptacle before disconnecting the product from the extension cord.

ALWAYS make certain that the power source required for the electric motor is correct and always use the correct NEMA configuration plug. Motors can burn out when the line voltage falls 10% below the voltage rating of the motor. Failure to use proper voltage will cause the motor to overheat. Make certain that the correct size grounded (3-wires) extension cord is used.



WARNING

Use of undersized extension cords result in low voltage to the motor that can result in motor burnout and premature failure. MK Diamond warns that equipment returned to us showing signs of being run in a low voltage condition, through the use of undersized extension cords, will be repaired or replaced totally at the customer's expense. There will be no warranty claim.

To choose the proper extension cord,

- Locate the length of extension cord needed in the table below.
- Once the proper length is found, move down the column to obtain the correct AWG size required for that length of extension cord.

EXTENSION CORD LENGTH							
Nameplate Amperes	115V	25'	50'	75'	100'	150'	200'
	250V	50'	100'	150'	200'	300'	400'
0 - 5		16	16	16	14	12	12
5.1 - 8		16	16	14	12	10	•
8.1 - 12		14	14	12	10	•	•
12.1 - 15		12	12	10	10	•	•
15.1 - 20		10	10	10	•	•	•

SAFETY LABEL LOCATIONS

Safety labels contain important safety information. Please read the information contained on each safety label. These labels are considered a permanent part of your machine. If a label comes off or becomes hard to read, contact MK Diamond or your dealer for a replacement.

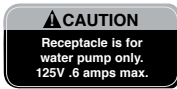

Label A



Label B



Label C



Label G

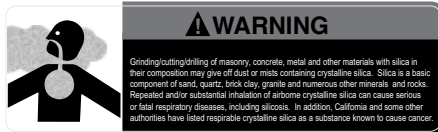

Label D

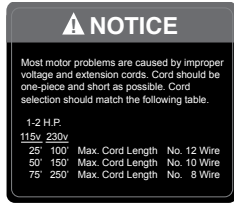

Label E

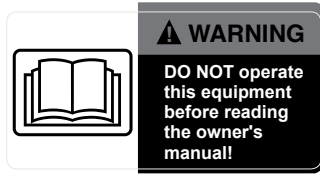

Label F

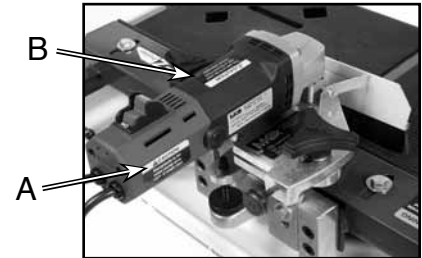

Warning Sheet Part # 166012

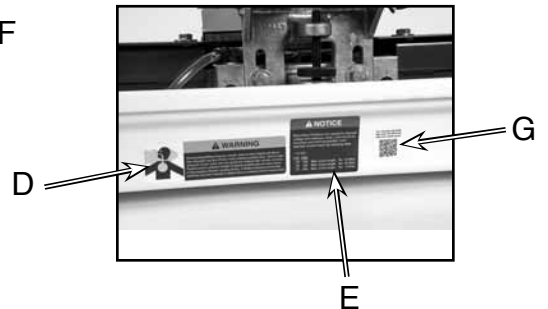
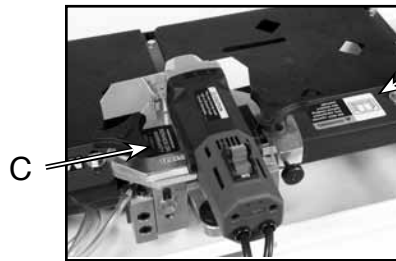

Decal/Label	Location	Description
A	Motor - Side	Caution - Receptacle is for Water Pump Only
B	Motor - Top	Caution - Use with GFCI outlet only
C	Motor - Mount	Service/ Warranty
D	Pan - Back	Warning - Silica Warning
E	Fence - Left	Warning - Read Owners Manual
F	Pan - Back	Notice - Voltage/extension cords
G	Pan - Back	QR Code for Manuals

PROFILER SPECIFIC WARNINGS

WARNING

- Wear eye protection.
- Use splash guard for every operation for which it can be used.
- Disconnect machine before servicing, when changing tools, and cleaning.
- Replace damaged profiling tool before operating.

GENERAL DESCRIPTION

Operated and used according to this manual, the MK-EZ Profiler will provide years of dependable service. The MK-EZ Profiler is engineered as a tabletop unit. The profiler includes a powerful 120v electric motor. It quickly and easily provides the initial shaping of the material before the follow up polishing operations.

MOTOR SPECIFICATIONS

Motor specifications for the MK-EZ Profiler are listed in the table below.

Voltage	120v
Overall Amperage	7.4 A
Frequency	50/60Hz
RPM	6000 rpm
Horse Power	1-1/4 hp

TOOL CAPACITY

The MK-EZ Profiler uses wet cutting profiling tools in the 3-1/2" to 4-1/2" diameter range. These tools have a 5/8"-18 female thread. See the accessories section for a complete list of tools, compatible with your MK-EZ Profiler, that are available from MK Diamond.

TILE TYPES

The MK-EZ Profiler can profile a variety of material types including stone, ceramic, slate, granite, marble, porcelain, and lapidary products.

NOTE: The MK-EZ Profiler is not designed to cut plastic or metals.

UNPACKING

CAUTION Use proper lifting techniques when lifting the MK-EZ Profiler. Remove the MK-EZ Profiler and accessory box from the carton.

CONTENTS

- One (1) MK-EZ Profiler Pan, Frame and Table Assembly,
- One (1) Cutting Head Assembly
- One (1) MK-400BDB 3/8 Radius Profiling Tool
- One (1) Electric Water Pump

- One (1) 1" Open End Wrench
- One (1) 11/16" Open End Wrench
- One (1) Owner's Manual
- One (1) Pump Manual
- One (1) Warranty Card



MK-EZ Profiler Pan, Frame & Table Assembly



Cutting Head



MK-400BDB



Electric Water Pump



1" & 11/16" Open End Wrench



Owner's Manual



Pump Manual



Warranty Card

TRANSPORT

CAUTION

1. The MK-EZ Profiler weighs approximately twenty-three (23) pounds; use care when transporting.
2. Never transport the MK-EZ Profiler with water in the Water Pan.

The MK-EZ Profiler is designed with a rigid, lightweight frame making the profiler easily transportable. To lift the profiler, grasp the left and right of the pan at the lift points shown below.



Follow the assembly instructions to prepare your MK-EZ Profiler for operation.

PUMP INSTALLATION



(A)
Remove base (with suction cups) from water pump (if included). Pull off front cover, slide base off of pump, and replace the cover.

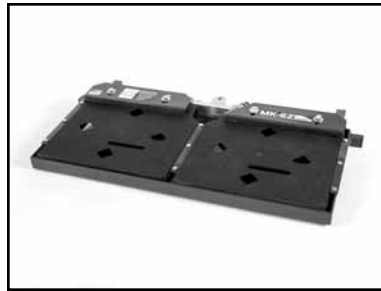

(B)
Remove the Frame Assembly from the pan, setting it next to the pan.



(C)
Attach the loose end of the water hose (that is attached to the water nozzle) to the pump.



(D)
Place pump in pan.

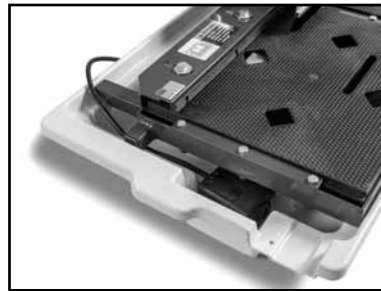

(E)
Place the Frame assembly back in the pan ensuring that the water hose is not pinched, and pump cord comes out of the pan at the back of the unit, where it can easily be plugged into the pump attachment plug on the motor (once the cutting head is installed).

CUTTING HEAD INSTALLATION



(A)
Remove the two bolts and washers at the back of the cutting head mount.



(B)
Place the cutting head in position and replace the bolts and washers, through the vertical slots in the cutting head slide.



(C)
Slide the head down, until the end of the vertical adjustment screw is sitting in the hole in the cutting head mount.



(D)
Tighten the screws using a 9/16" wrench (not included).

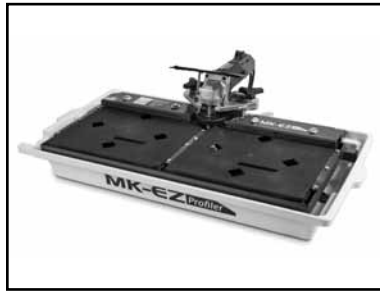

(E)
Place frame in pan.

PROFILE TOOL INSTALLATION

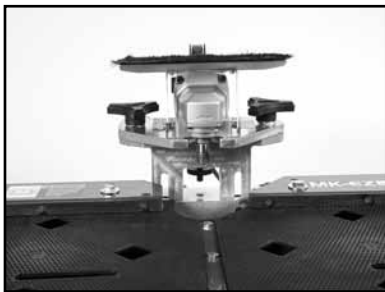

(A)
Loosen the two screws on the cutting head slide, and without using the vertical adjustment screw, slide the head to its highest position and retighten the screws to hold it there.



(B)
Place the tool on the motor spindle and spin it on by hand.



(C)
Then using the two wrenches provided, tighten it up. The smaller wrench fits the flats on the motor spindle to hold it from turning, while the larger 1" wrench fits the profiling tools.

FENCE ADJUSTMENT

Once a tool has been installed, the fences can be adjusted for use with that particular tool.



(A)
Flip the splash guard brush up out of the way.

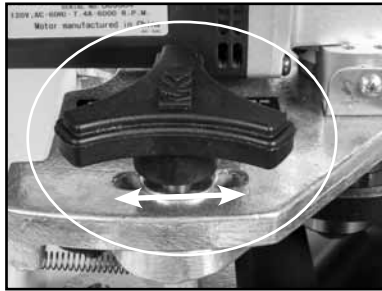

(B)
Ensure that the fine horizontal adjustment is approximately in the center of its adjustment slot.

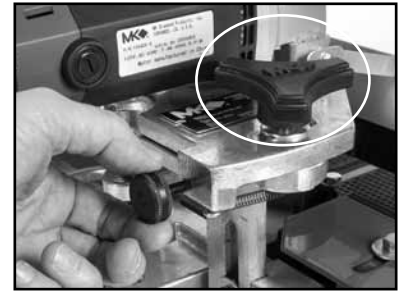

(C)
This adjustment operates by loosening (about a quarter turn) both of the large knobs next to the motor, turning the fine horizontal adjustment knob in or out as necessary and retightening the knobs.

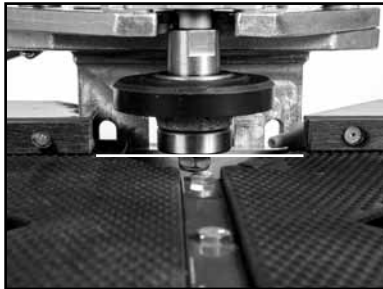

(D)
Loosen the vertical slide bolts, raise the head so that the middle of the lower guide bearing on the tool is level with the table surface and tighten the bolts.



(E)
Loosen the two bolts on both fences and slide them towards the back of the machine.

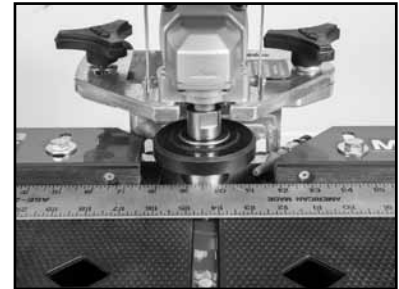

(F)
Place a straight edge (at least 24" long) on the table, so that it is touching the guide bearing on the tool, and is approximately parallel with the long direction of the tables.



(G)
Holding the straight edge firmly in place, slide the left fence into contact with the straight edge and tighten the two bolts that hold it.



(H)
Now holding the straight edge in contact with the left fence (and guide bearing), bring the right fence up to touch the straight edge and tighten it in place.

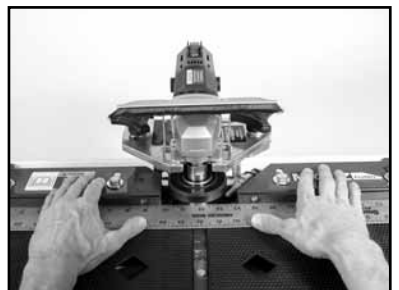

(I)
The two fences should now be parallel and the straight edge should be able to slide from one to the other without bumping or catching. The profile tool can now be set for the desired cut.

PROFILE ADJUSTMENT



(A)

Adjust the cutting head vertical position for the thickness of the material. Adjustment is made by loosening the two slide bolts.



(B)

Using the fine vertical adjustment knob.



(C)

Move the head up or down until the material to be profiled just touches the underside of the profile tool upper guide. Retighten the slide bolts.



(D)

The tool is now adjusted to make the maximum profile that the tool will make. Fine adjustments can be made to the profile by using the vertical and horizontal adjustment knobs (loosening and retightening their appropriate fixing screws).

CONNECTING THE WATER PUMP



WARNING

1. To prevent the possibility of electrical shock, the MK-EZ Profiler MUST be de-energized when connecting the Water Pump.
2. To prevent the possibility of electrical shock, use only MK Diamond authorized replacement parts.

NOTE: To prevent pump damage, the Water Pump must be disconnected if cutting dry.

WATER PUMP SETUP FOR OPERATION

The Water Pump can be setup for operation in two ways: External Water Source or Re-circulation.

NOTE: If cutting dry DO NOT connect the water pump.

RE-CIRCULATION

NOTE: When using the re-circulation method, the water should be changed often for longer pump life.



(A)

Ensure the Drain Plug is installed in the Water Basin



(B)

Place the Water Pump in the back of the Water Basin

PRE-START INSPECTION

Prior to beginning work, a pre-start inspection of the machine should be performed.



CAUTION

1. Before powering or starting, check for damage that could prevent this equipment from proper operation or performing its intended function. Check for binding and alignment of moving parts. Check for damaged, broken, or missing parts.
2. Verify the On/Off switch is in the OFF position.
3. Before connecting the MK-EZ Profiler to a power supply, be sure the voltage, cycle and phase of the job site power source meet the requirements.

WATER NOZZLE ADJUSTMENT

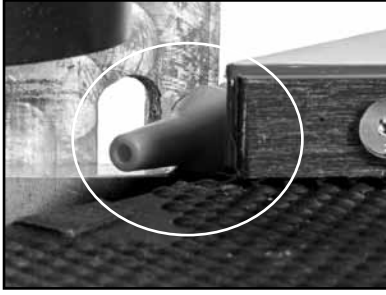

(A)

The water nozzle can be pivoted to provide the best aim for delivering water to the contact area between the material and the tool.

NOTE: The best water nozzle adjustment depends on several factors, including the material thickness and profile tool used. The water pump receptacle cord, that comes out of the motor, turns on and off along with the motor. The pump can be plugged into a receptacle or extension cord to test the aim of the water stream, and to make adjustments without the motor and tool running.

PROFILING

Once everything is set up, profiling is performed by sliding the material through the Profiling Tool from Left to Right.



(A)

Flip the splash guard brush down onto the table, turn on the motor and proceed with a test cut.

NOTE: Most profiles can be cut in one pass. If the material comes away from the fence while profiling, less than the full amount of material will be removed and a second pass will finish up the profile.

MK-EZ PROFILER PART # 170565

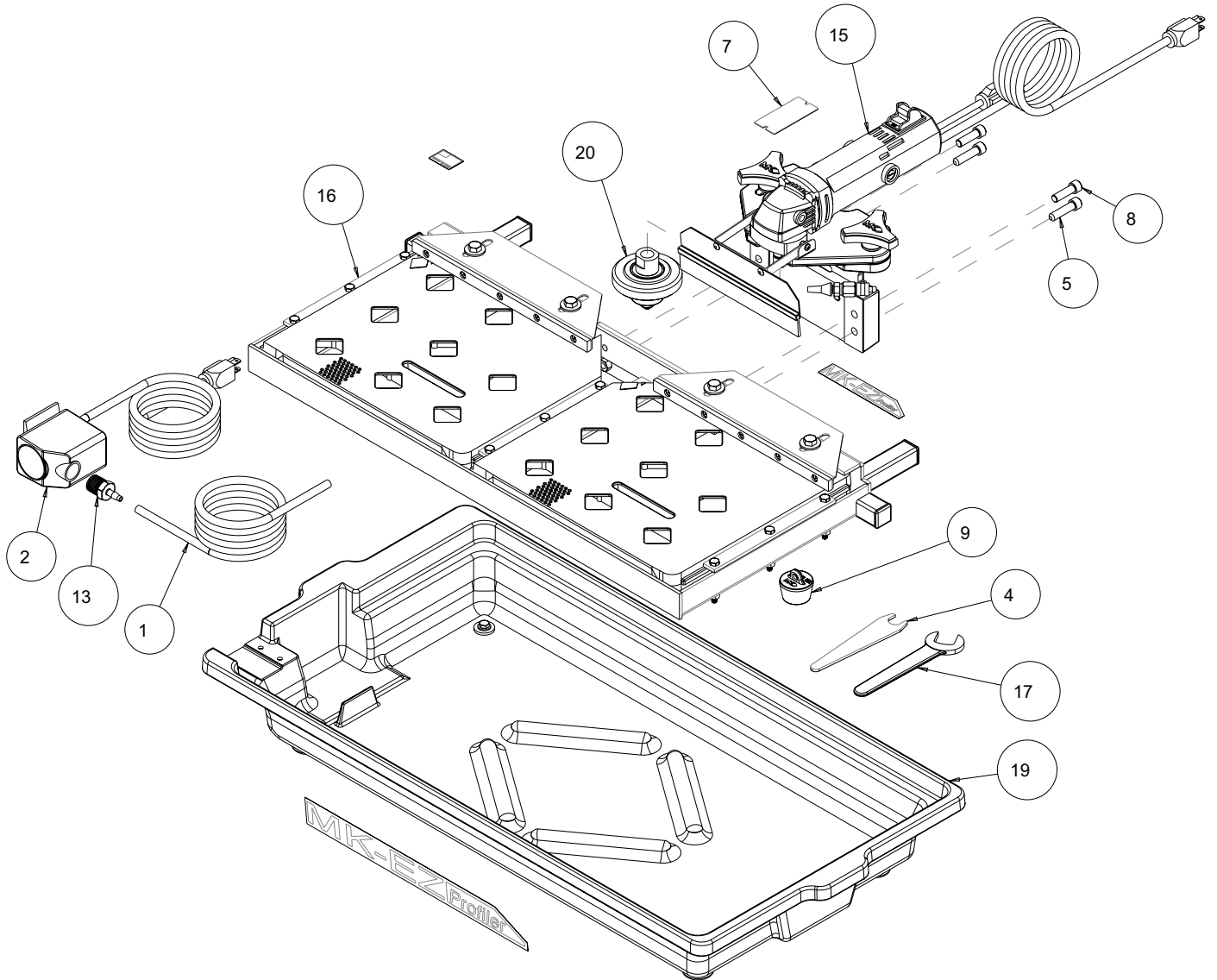

MK-EZ PROFILER PART # 170565

ITEM	DESCRIPTION	PART#	QTY.
1	HOSE, VINYL, 1/4 X 3/8 (6.0')	132951	1
2	PUMP, WATER 115V/60HZ UL/CSA	151271-VP	1
3	CARTON, 13-1/2 X 12-1 X 9 - 3/4	152565	1
4	WRENCH, TILES AW, 11/16 OPEN END	153450	1
5	SCREW, SOCKET HEAD CAP 3/8 - 16 X 1	154685	2
6	CARD, WARRANTY REGISTER SAW	155037	1
7	TAG, SERIAL NUMBER, BLANK	157500-RW	1
8	SCREW, SOCKET HEAD CAP 3/8 - 16 X 1-14	157529	2
9	DRAIN PLUG, W/RING	159529	1
10	MASONRY LABEL SHEET (NOT SHOWN)	166011	1
11	CARTON, MK100/101 SERIES PL KR	166621-01PL	1
12	CARTON, TRAY, MK-100/101	166621-05	1
13	ADAPTER, 1/2 NPT X 1/4 BARB	168261	1
14	OWNERS MANUAL, MK-EZ PROFILER	170565-OM	1
15	ASSY, MOTOR, 120V, EZPR	170650	1
16	ASSY, FRAME AND TABLE, EZPR	170754	1
17	WRENCH, 1" OPEN END, THIN	170799	1
18	SHEET, LABEL, EZPR	170801	1
19	ASSY, PAN, EZPR	170805	1
20	MMK-400BDB 3-1/2 X 5.8-18 3/8R	400038-18	1

MK-EZ PROFILER ASSY, MOTOR PART # 170650

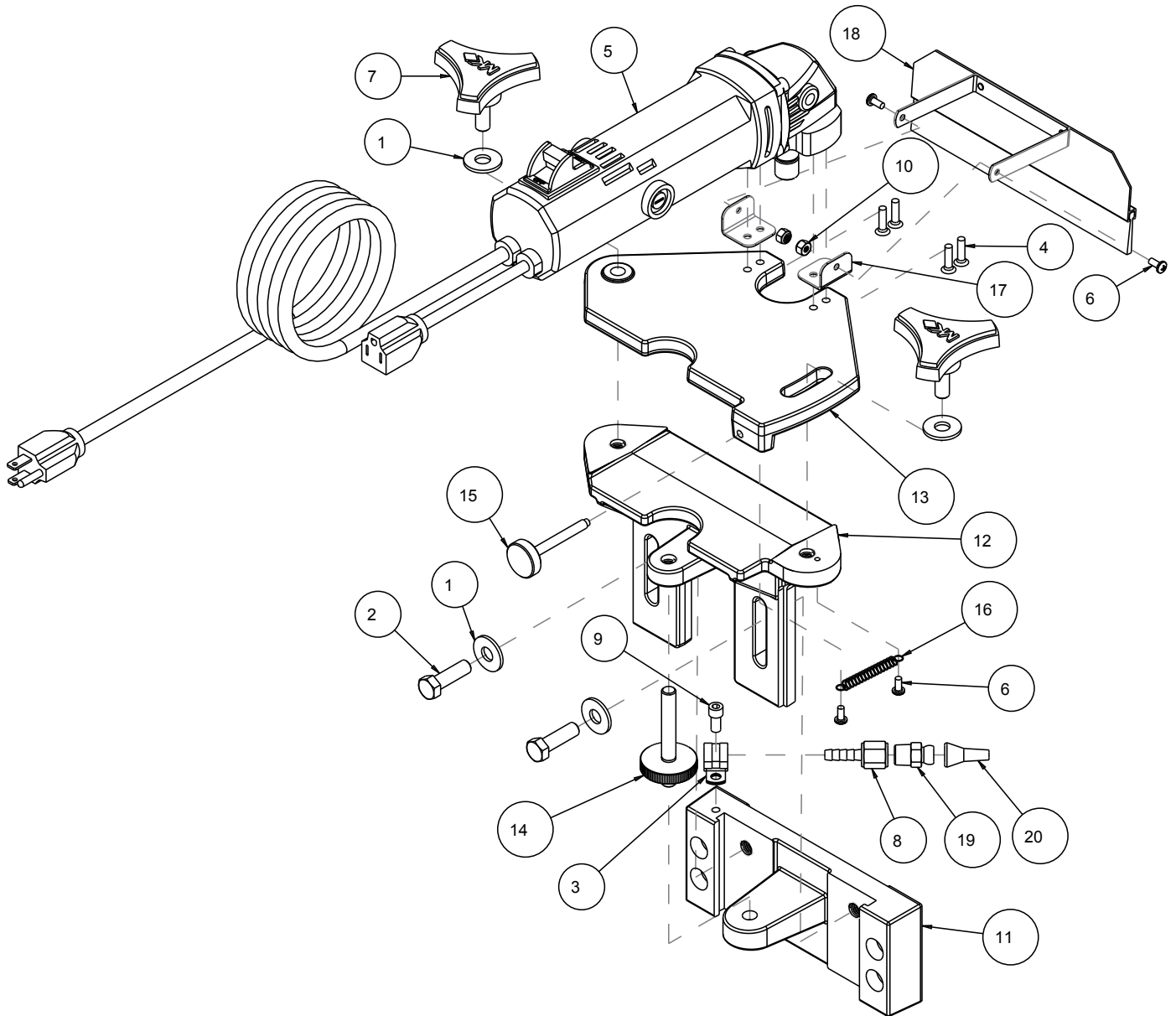

MK-EZ PROFILER ASSY, MOTOR PART # 170650

ITEM	DESCRIPTION	PART#	QTY.
1	WASHER, FLAT, USS, 3/8	101360	4
2	SCREW, 3/8-16 X 1-1/4 HEX HEAD CAP	150774	2
3	CLAMP, CUSHION LOOP 3/8	152592	1
4	SCREW, FLAT HEAD 1-32 X 5/ 8"	153902	4
5	MTR, ELECT, 7.4 AMP 120V	156428-R	1
6	SCREW, 8 -32 X 3/8 PAN HEAD PHILLIPS	156614	4
7	KNOB, TRI PLASTIC, 1"	156770-01	2
8	FITTING, 1/4 FNPT X 1/4 BARB	162601	1
9	SCREW, 1/4-20 X 1/2 SOCKET HEAD CAP	162778	1
10	NUT, HEX, NYL, 8-32	165227	2
11	CASTING, BASE, EZPR, COMP	170656	1
12	CASTING, SLIDE, EZPR, COMP	170658	1
13	CASTING, MTR MOUNT, EZPR, COMP	170660	1
14	KNOB, 3/8-16 X 3, EZPR	170741	1
15	KNOB, 1/4-20 X 2, EZPR	170742	1
16	SPRING, EXTEN, .250 X 1.0 X .023	170743	1
17	BRACKET, BRUSH MNT, EZPR	170793	2
18	ASSY, BRUSH, EZPR	170794	1
19	FITTING, 1/4 MNPT X LOC-LINE	170797	1
20	NOZZLE, LOC-LINE, 1/8"	170798	1

MK-EZ PROFILER ASSY, FRAME & TABLE PART # 170754

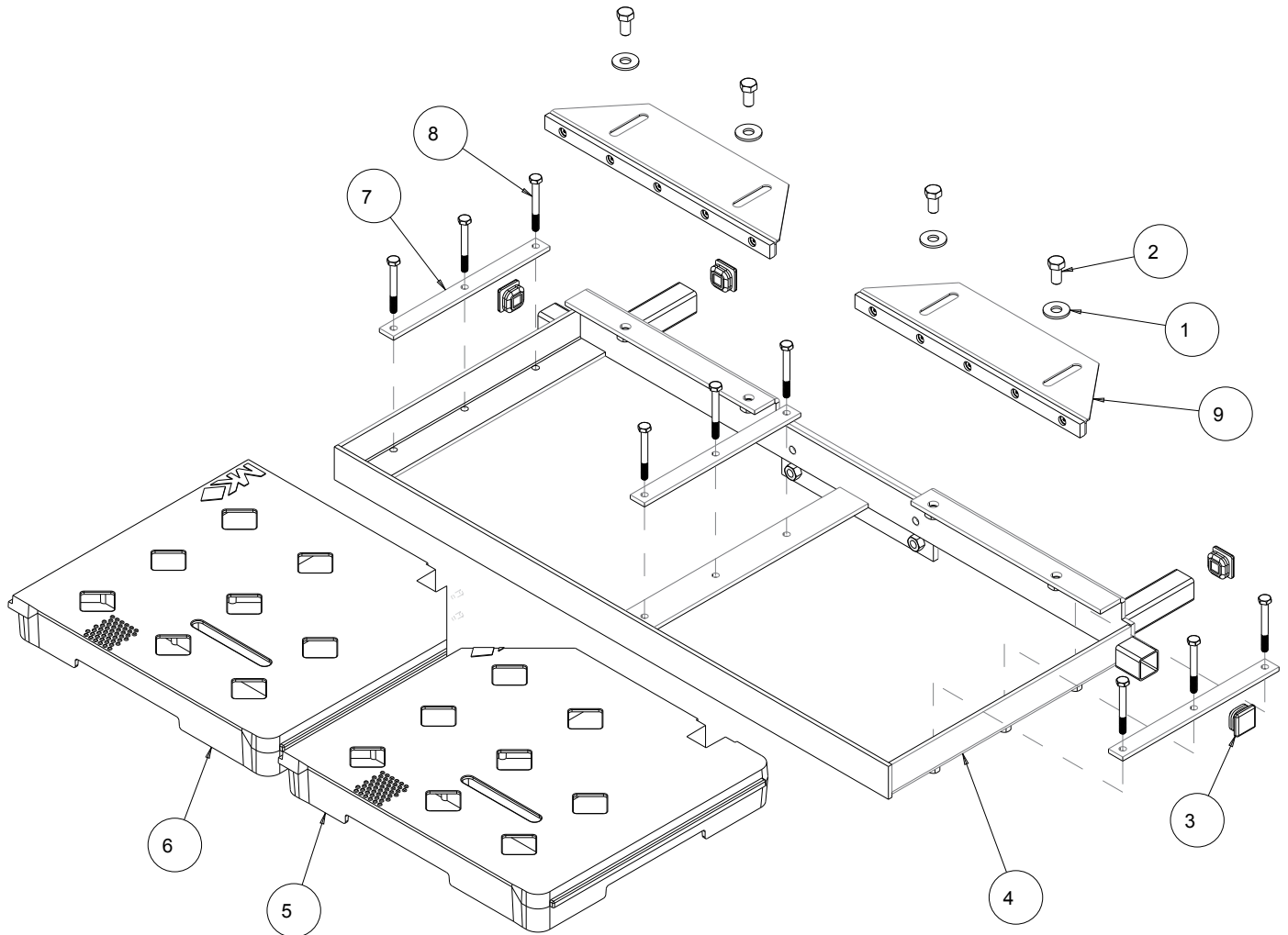

ITEM	DESCRIPTION	PART#	QTY.
1	WASHER, FLAT, USS, 3/8	101360	4
2	SCREW, HEX, 3/8-16 X 3/4	153527	4
3	PLUG, PLASTIC, 1 SQ-14-20 GA	160727-1	4
4	FRAME, EZ PROFILER	170649	1
5	TABLE, LEFT, EZPR, COMP	170651	1
6	TABLE, RIGHT, EZPR, COMP	170652	1
7	STRAP, TABLE, EZPR	170653	3
8	SCREW, HEX HD, 1/4- 0 X 2-1/4	170752	9
9	ASST, FENCE, EZPR	170755	2

MK-EZ PROFILER ASSY, FRAME & TABLE PART # 170755

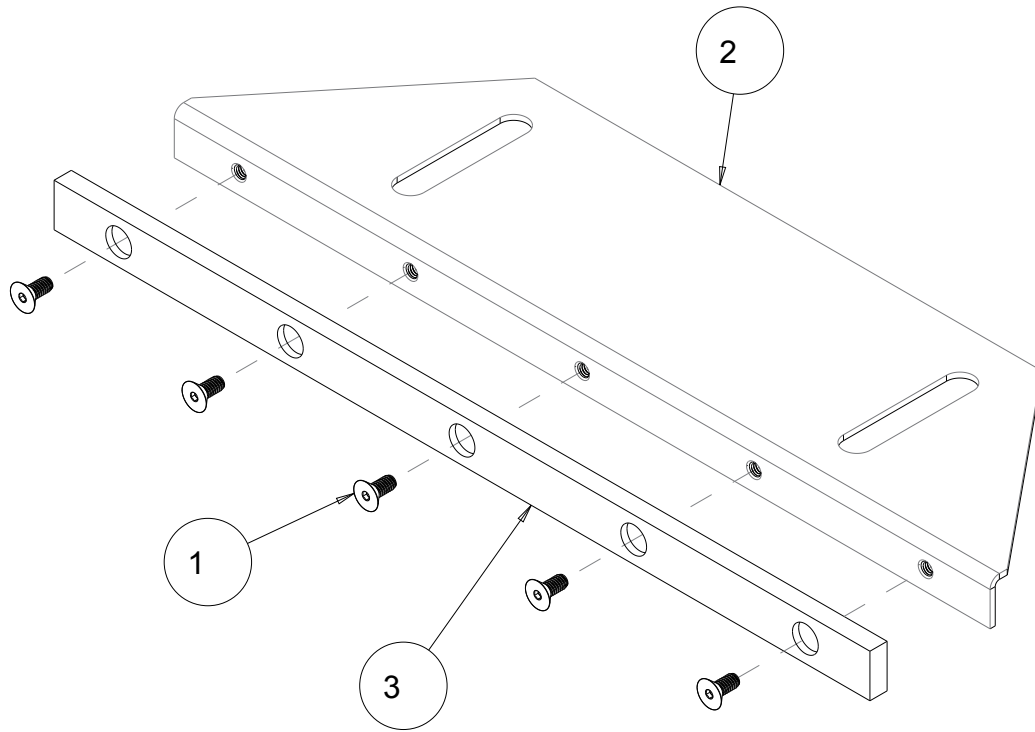

ITEM	DESCRIPTION	PART#	QTY.
1	SCREW, FLAT HEAD CAP #8-32 X 3/8	165437	5
2	FENCE, EZPR	170654	1
3	STRIP, DELRIN, 1/4 X 5/8 X 12, COMP	170753	1

MK-EZ PROFILER PAN PART # 170805

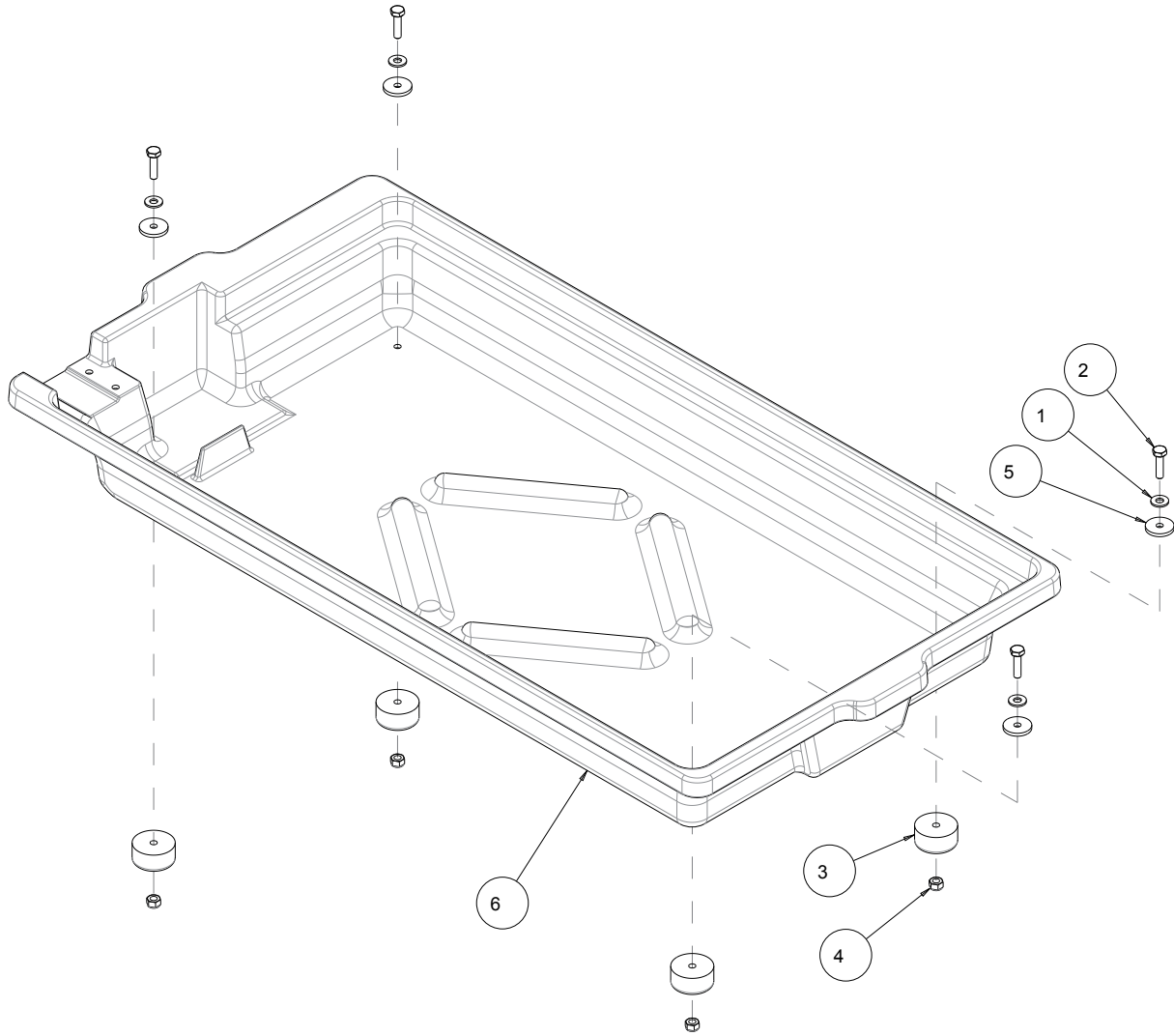

ITEM	DESCRIPTION	PART#	QTY.
1	WASHER, FLAT, SAE, 1/4	151915	4
2	SCREW, HEX, HD, TAP, 1/4-20 X 1	152676	4
3	BUMPER, 1/4 HD, TAP, 1/4-20 X 1	154496	4
4	NUT, HEX, NYLK, 1/4-20	159857	4
5	WASHER, 1/4 RUBBER FENDER	164593	4
6	PAN, PLASTIC, EZPR	170804	1

ACCESSORIES

MK Diamond Profile Bits are designed to achieve a quality finish on all profile and bevel shapes. They are for profiling tile, marble, granite, and all types of stone with superior performance and durability.



MK-400BDB Brazed Diamond Profile Bits

Diameter	Profile/Radius	Diameter	Nut	Part #
3-1/2"	A - 3/8"	3-1/2"	5/8" - 18	400038-18
3-1/2"	A - 3/16"	3-1/2"	5/8" - 18	400039-18
3-1/2"	B - 1/2"	3-1/2"	5/8" - 18	400012-18
4"	C - 3/4"	4"	5/8" - 18	400034-18
4"	E - 45° Bevel	4"	5/8" - 18	400040-18



MK-480SDR Segmented Diamond Profile Bits

Shape	Profile/Size	Diameter	Nut	Part #
Half Bullnose	B-10mm	3-1/2"	5/8" - 18	480010-18
Half Bullnose	B-15mm	3-3/4"	5/8" - 18	480015-18
Half Bullnose	B-20mm	3-3/4"	5/8" - 18	480020-18
Ogee	F-20mm	3-1/2"	5/8" - 18	480120-18

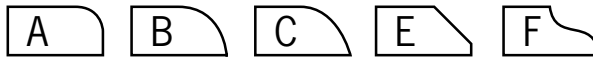

ORDERING INFORMATION

You may order MK Diamond products through your local MK Diamond distributor or, you may order direct from MK Diamond.

When ordering direct from MK Diamond, please have the following information ready before calling:

- The Model Number of the equipment
- The Serial Number of the equipment
- Where the equipment was purchased and when
- The Part Number for the part(s) being ordered
- The Part Description for the part(s) being ordered

NOTE: There is a \$25.00 minimum order when ordering direct from MK Diamond. A \$6.00 charge will be added to orders having a net billing value under \$50.00. All purchases must be made using VISA, MasterCard or American Express.

All parts may be ordered by calling toll free to – 800 421-5830 or 310 539-5221 and asking for Customer Service. For technical questions, call – 800 474-5594.

RETURN MATERIALS POLICY

To expedite the service relative to the return of a product purchased through MK Diamond, please observe the following:

NOTE: When returning all items, they must have been purchased within the previous twelve (12) months.

- Have the Model Number of the equipment
- Have the Serial Number of the equipment
- Have the location of where the equipment was purchased
- Have the date when the equipment was purchased
- Contact Customer Service for approval to return the item(s)
- Obtain a Returned Goods Number (RGA) authorizing the return
- Follow the packaging instructions in the following section
- Ensure your item(s) are prepaid to the destination

For returned items, call toll free to – 800 421-5830 or 310 539-5221 and ask for Customer Service. For technical questions, call – 800 474-5594 or 310 257-2845.

PACKAGING INSTRUCTIONS

- Remove the Cutting Head
- Dry the equipment before shipping
- When packing, include the following: Profiler, Diamond Tool and Frame Assembly
- Package the unit in its original container or one of comparable size (do not ship the unit partially exposed)
- Ensure all parts are secured in the packaging to prevent moving

AUTHORIZED SERVICE CENTERS

For quicker repair time, you may contact MK Diamond Customer Service, toll free, at 800 421-5830 or 310 539-5221 for the Authorized Service Center closest to you or visit our web site at www.mkdiamond.com. For technical questions, call – 800 474-5594.

CONTACT:

Please contact MK Diamond Products, Inc. Customer Service Department with any questions you might have regarding distributors, parts or service.

Telephone: **(800) 421-5830**

Fax: **(310) 539-5158**

E-mail: **Customer_Service@MKDiamond.com**

Customer Service Hours: **Monday through Friday, 6AM-4PM PST**

**MK Diamond Products, Inc.
1315 Storm Parkway
Torrance, CA 90501**

MK DIAMOND PRODUCTS, INC. LIMITED WARRANTY

MK DIAMOND PRODUCTS, INC. will guarantee every machine they build, to be free from defects in material and workmanship for (1) one year from date of purchase. The obligation of MK DIAMOND PRODUCTS, INC. under this warranty is limited to the repair or replacement of any parts which, under normal use, prove to be defective in material or workmanship. The parts involved or the unit in question should be returned to MK DIAMOND PRODUCTS, INC. or to a point designated by us, transportation prepaid.

This warranty does not obligate us to bear the cost of labor or transportation charges in connection with replacement or repair of defective parts. Likewise, it shall NOT apply to any unit which has been subjected to misuse, neglect or accident. This warranty does NOT apply to any machine which has been repaired or altered outside our factory.

This warranty does NOT obligate MK DIAMOND PRODUCTS, INC., with respect to items not of our manufacture, such as engines, motors, hydraulics, etc., which are subject to their own guarantees and warranties.

We shall in no event be liable for consequential damages or contingent liabilities arising out of failure of any equipment or parts to operate properly.

© COPYRIGHT 2013, MK DIAMOND PRODUCTS, INC. ALL RIGHTS RESERVED.

The MK Diamond logo is a registered trademark of MK Diamond Products, Inc. and may not be used, reproduced, or altered without written permission. All other trademarks are the property of their respective owners and used with permission.

MK Diamond may have patents, patent applications, trade marks, copyrights of other intellectual property right covering this product in this document.

This manual MUST accompany the equipment at all times. This manual is considered a permanent part of the equipment and should remain with the unit if resold.

The information and specifications included in this publication were in effect at the time of approval for printing.

MK-EZ PROFILER
OWNER'S MANUAL, PARTS LIST
& OPERATING INSTRUCTIONS



MK Diamond Products, Inc.

MK Diamond Products, Inc.
1315 Storm Parkway
Torrance, CA 90501

Toll-Free: (800) 421-5830
Phone: (310) 539-5221
Fax: (310) 539-5158
www.mkdiamond.com