

MK DIAMOND TRACK RAIL SAW OPERATION & PARTS MANUAL



Revision 303	08.2015
Manual Part No. 166110	

Caution: Read all safety and operating instructions before using this equipment. This manual **MUST** accompany the equipment at all times.

Congratulations on your purchase of a Track Rail Saw. We are certain that you will be pleased with your purchase. MK Diamond takes pride in producing the finest construction power tools and diamond blades in the industry.

Operated correctly, your Track Rail Saw should provide you with years of service. In order to help you, we have included this manual. This owners manual contains information necessary to operate and maintain your Track Rail Saw safely and correctly. Please take the time to familiarize yourself with the Track Rail Saw by reading and reviewing this manual.

Read and follow all safety, operating and maintenance instructions.

If you should have questions concerning your Track Rail Saw, please feel free to call our friendly customer service department at: 800 421-5830

Regards,

MK Diamond

NOTE THIS INFORMATION FOR FUTURE USE:

MODEL NUMBER:	
SERIAL NUMBER:	
PURCHASE PLACE:	
PURCHASE DATE:	

NOTE: For your (1) one year warranty to be effective, complete the warranty card (including the Serial Number) and mail it in as soon as possible.

MK DIAMOND TRACK RAIL SAW**PAGE NO.****SAFETY**

Safety Message/Alert Symbols	4
Safety Warnings	5
Hazard Symbols	6
Electric Motor Safety	7
Rules for Safe Operation	8-9
Operation & Safety Decals	10

PRODUCT SPECIFICATIONS

Specifications	11
----------------	----

SET-UP

Rail Assembly	12
Rail Assembly Connector	13
Cutting Head Assembly	14
Material Clamps & Alignment	15
Hose Set-Up	16

OPERATION

Plunge Cutting for a 90° Cut	17
Plunge Cutting for a Miter Cut	18

MAINTENANCE

Blade Replacement	19
Filter Replacement	20
Roller Wheel Replacement	21-23

GENERAL PRODUCT INFORMATION

Parts List: Final Assembly	24-25
Parts List: Main Carrier Assembly	26-27
Parts List: Cutting Head Assembly	28-29
Parts List: Blade Guard Assembly	30
Parts List: Parallel Rail Support Bracket	31
Parts List: Rail Connector Plate	32
Parts List: Rail Saw Material Clamp	33
Ordering Information	34
Contact Information and Limited Warranty	35

Safety precautions should be followed at all times when operating this equipment. Failure to read and understand the Safety Precaution and Operating Instructions could result in injury to yourself and others.

This Operation Manual has been developed to provide complete instructions for the safe and efficient operation of the CX-3® Concrete Saw.

Before using this saw, ensure that the person operating the equipment has read and understands all instructions in this manual.

SAFETY MESSAGE / ALERT SYMBOLS

A safety message alerts you to potential hazards that could hurt you or others. Each safety message is preceded by a safety alert symbol () and one of three words: **DANGER**, **WARNING**, or **CAUTION**.

DANGER

You **WILL** be **KILLED** or **SERIOUSLY INJURED** if you do not follow directions.

WARNING

You **CAN** be **KILLED** or **SERIOUSLY INJURED** if you do not follow directions.

CAUTION

You **CAN** be **INJURED** if you do not follow directions. It may also be used to alert against unsafe practices.

Each message tells you what the hazard is, what can happen, and what you can do to avoid or reduce injury. Other important messages are preceded by the word **NOTICE**.

NOTICE

You can cause **PROPERTY DAMAGE** to your machine if you don't follow directions.

The safety labels should be periodically inspected and cleaned by the user to maintain good legibility at a safe viewing distance. If the label is worn, damaged or illegible, it should be replaced. Contact MK Diamond or your dealer for replacement.

DAMAGE PREVENTION AND INFORMATION MESSAGES

A Damage Prevention Message is to inform the user of important information and/or instructions that could lead to equipment or other property damage if not followed. Information messages convey information that pertains to the equipment being used. Each message will be preceded by the word **NOTE**, as in the example below.

NOTE: Equipment and/or property damage may result if these instructions are not followed.

SILICA DUST WARNING

Grinding/cutting/drilling of masonry, concrete, metal and other materials with silica in their composition may give off dust or mists containing crystalline silica. Silica is a basic component of sand, quartz, brick clay, granite and numerous other minerals and rocks. Repeated and/or substantial inhalation of airborne crystalline silica can cause serious or fatal respiratory diseases, including silicosis. In addition, California and some other authorities have listed respirable crystalline silica as a substance known to cause cancer. When cutting such materials, always follow respiratory precautions.

CALIFORNIA PROPOSITION 65 MESSAGE

Some dust created by power sanding, sawing, grinding, drilling, and other construction activities contain chemicals known (to the State of California) to cause cancer, birth defects or other reproductive harm. Some examples of these chemicals are:

- Lead, from lead-based paints
- Crystalline silica, from bricks and cement and other masonry products
- Arsenic and chromium, from chemically treated lumber

For further information, consult the following sources:

<http://www.osha.gov/dsg/topics/silicacrystalline/index.html>

<http://www.cdc.gov/niosh/consilic.html>

<http://oehha.ca.gov/prop65/law/P65law72003.html>

<http://www.dir.ca.gov/Title8/sub4.html>

Your risk from these exposures varies depending on how often you do this type of work. To reduce your exposure to these chemicals, work in a well-ventilated area, and work with approved safety equipment, such as those dust masks that are specially designed to filter out microscopic particles.

Potential hazards associated with the MK Diamond Track Rail Saw will be referenced with Hazard Symbols which appear throughout this manual, and will be referenced in conjunction with Safety Message Alert Symbols.

HAZARD SYMBOLS



ALWAYS read this Owner's Manual before operating the machine.



ALWAYS wear approved eye protection.



ALWAYS wear approved ear protection.



ALWAYS wear approved respiratory protection.



ALWAYS wear a hard hat.



ALWAYS avoid inhalation of and skin contact with silica dust and/or mist.

**WARNING**

DO NOT use woodcutting, or carbide blades on this machine! Use **ONLY** Diamond blades on machine. Use machine only to cut tile and masonry products. **DO NOT** use machine to cut wood or wood products.

ELECTRIC MOTOR SAFETY

For maintenance care and operation of the electric motor, refer to your electric motor instruction booklet furnished with the electric motor.

Protect the electric motor from dust as much as possible and keep ventilating openings clean.

**CAUTION**

- **DO NOT** spray water at any time on the electric motor.
- **DO NOT** operate electric motor in an explosive environment.

Electric Motor Connection

The table below shows the matching NEMA approved connector for the required extension cord.

ALWAYS make certain that the power source required for the electric motor is correct and always use the correct NEMA configuration plug. Failure to supply the correct voltage to the motor can severely damage the motor. Make certain that the correct size grounded (3-wires) extension cord is used. See the table below.

Motors can burn out when the line voltage falls 10% below the voltage rating of the motor. Failure to use proper voltage will cause the motor to overheat.

MOTOR SPECS			EXTENSION CORD LENGTH			
Motor	Voltage	Amps	25'	50'	100'	200'
157801	115V 1 Ph	15	14 ga	10 ga	8 ga	4 ga

RULES FOR SAFE OPERATION



DANGER

Failure to follow instructions in this manual may lead to serious injury or even death! This equipment is to be operated by trained and qualified personnel only! This equipment is for industrial use only.

The following safety guidelines should always be used when operating the MK-2000 Electric Saw.

GENERAL SAFETY



- **DO NOT** operate or service this equipment before reading this entire manual.

- This equipment should not be operated by persons under 18 years of age.
- **NEVER** operate this equipment without proper protective clothing, shatterproof glasses, steeltoed boots and other protective devices required by the job.
- **NEVER** operate this equipment when not feeling well due to fatigue, illness or taking medicine.
- **NEVER** operate this equipment under the influence of drugs or alcohol.
- Whenever necessary, replace nameplate, operation and safety decals when they become difficult to read.
- **ALWAYS** check the machine for loose bolts before starting.



- **ALWAYS** wear proper respiratory (mask) hearing and eye protection equipment when operating this machine.

- **ALWAYS** store equipment properly when it is not being used. Equipment should be stored in a clean, dry location out of the reach of children.



- **NEVER** leave the machine unattended. Turn off electric motor when unattended.

- **CAUTION** must be observed while servicing the machine. Rotating parts can cause injury if contacted.
- Ensure that any electrical extension cord is protected against damage. Always ensure that the electrical extension cord is not trapped underneath the machine. When using an extension cord, be sure to use one heavy enough to carry the current your product will draw. An undersized cord will cause a drop in line voltage that will result in a loss of power and overheating. The Table shown on page 11 shows the correct AWG size to use depending on cord length and nameplate ampere rating. If in doubt, use the next heaviest gage. The smaller the gage number, the heavier the cord.



- **DO NOT** allow extension cord to come into contact with water or fluids.
- **DO NOT** spray water onto electric motor.
- **NEVER** operate the machine in an explosive atmosphere.

- Before starting the machine, check that all guards are in position and correctly fitted.
- Keep area around the machine clear of obstructions which could cause persons to fall onto moving parts.
- **ALWAYS** ensure that the machine is on level ground before using.
- **DO NOT** overreach. Keep proper footing and balance at all times.

- **NEVER** stand on the tool. Serious injury could occur if a power tool is tipped, or if a cutting tool is unintentionally contacted.
- Become familiar with the controls of the machine before operating. Know how to stop the machine quickly in case of emergency.
- **ALWAYS** secure work. Clamps or a vise should be used to hold work whenever practical. Keeping your hands free to operate a power tool is safer.
- **ALWAYS** disconnect AC power plug from power source before moving, cleaning or servicing the machine.
- **NEVER** leave a tool running unattended. Do not leave a tool until it comes to a complete stop. **ALWAYS** turn a power tool **OFF** when leaving the work area, or when a cut is finished.
- Make sure the OFF/ON power switch on the electric motor is always in the **OFF** position before inserting the machine's power plug into an AC receptacle.
- Operate electric motor only at the specified voltage indicated on the nameplate.
- **NEVER** disconnect any "emergency or safety devices". These devices are intended for operator safety. Disconnection of these devices can cause severe injury, bodily harm or even death! Disconnection of any of these devices will void all warranties.
- Unauthorized equipment modifications will void all warranties. Manufacturer does not assume responsibility for any accident due to equipment modifications.
- **NEVER** use accessories or attachments, which are not recommended by MK Diamond for this equipment. Damage to the equipment and/or injury to user may result.
- Replace damaged cutting blade before operating.
- **NEVER** try to stop a moving blade with your hand.

**WARNING**

NEVER use this machine with any cutter designed for wood working.

MAINTENANCE SAFETY

- **NEVER** lubricate components or attempt service on a running machine.
- Keep the machinery in proper running condition.
- Before using a power tool, check for damaged parts. A guard or any other part that is damaged should be carefully checked to determine if it would operate properly and perform its intended function. Always check moving parts for proper alignment or binding. Check for broken parts and mountings and all other conditions that may affect the operation of the power tool. A guard, or any damaged part, should be properly repaired or replaced.

SAW SAFETY

**WARNING**

- Wear eye protection.
- Disconnect saw before servicing, when changing cutting blades and cleaning.
- Replace damaged cutting blade before operation.
- Remove adjusting keys and wrenches.

OPERATION & SAFETY DECALS

The MK Diamond Track Rail Saw is equipped with a number of safety decals. These decals are provided for operator safety and maintenance information. The illustration below also shows the location of these decals. Should any of these operation or safety decals become unreadable, replacements can be obtained by calling (800) 262-1575.

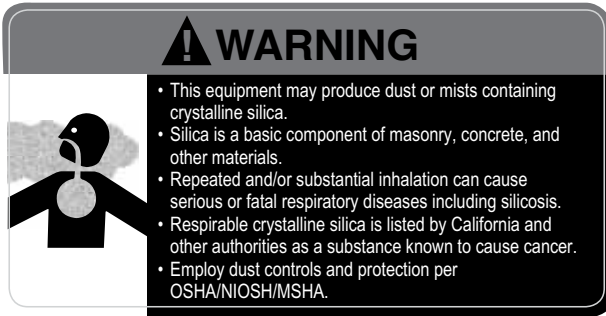

Part # 164202

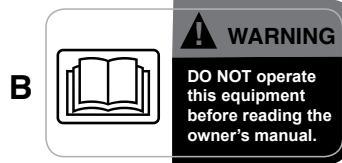

Part # 154398



Part # 155587



Part # 155678



Part # 155038

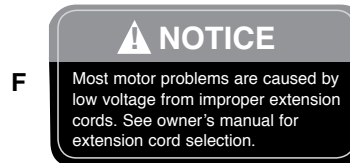

Part # 155672



Part # 170480

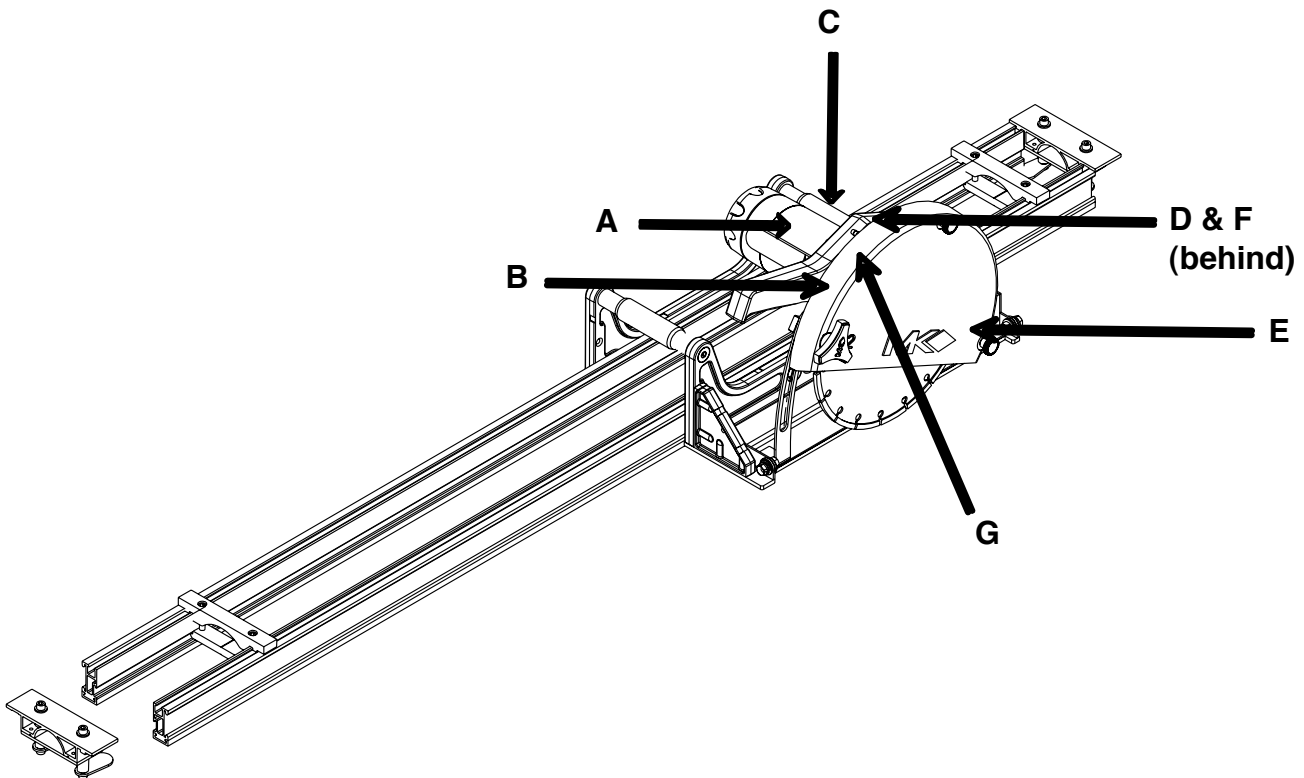

Track Rail Saw Specifications	
Model	166110
Motor	115V 50/60 Hz
Amps	15
Horsepower	1-3/4 HP
Blade RPM	3,500
Blade Capacity	12" (254 mm)
Arbor Size	1" (25.4 mm)
Standard Length of Cut	130" (3,202mm)
Maximum Depth of Cut	2-7/8" (73mm)
Depth of Cut at 45°	2-1/4 (57mm)
Weight	95 lbs. (43kgs.)
Dimensions (LxWxH) - inches	144" x 16" x 13"
Dimensions (LxWxH) - millimeters	3,658 x 406 x 330

- Adjustable height plunge-cutting head
- Lightweight precision extruded aluminum rails provide accurate and even tracking during all cutting operations
- Rails have replaceable slip-on pads to protect material surface from scratches
- Precision, maintenance-free bearings provide smooth and reliable tracking of the cutting head
- Replaceable dust filter
- Valve controlled water feed
- 72" 115V standard U-ground electrical cord
- Saw comes complete with two sets of 72" track, track connector plate, 12" blade capacity cutting head, two hold-down clamps and standard garden hose water connector
- Additional rails for extending cutting capacity sold separately

Rail Assembly

1. Lay Rails (A & B) on a flat and leveled surface.
2. Align ends of Rails.
3. Slide Parallel Rail Support Brackets (C) from both ends of rail.
4. Tighten screws until Brackets hold Rails firmly in place (D).
5. Repeat Step 1 through 4 if a length of more than 6 feet is needed.

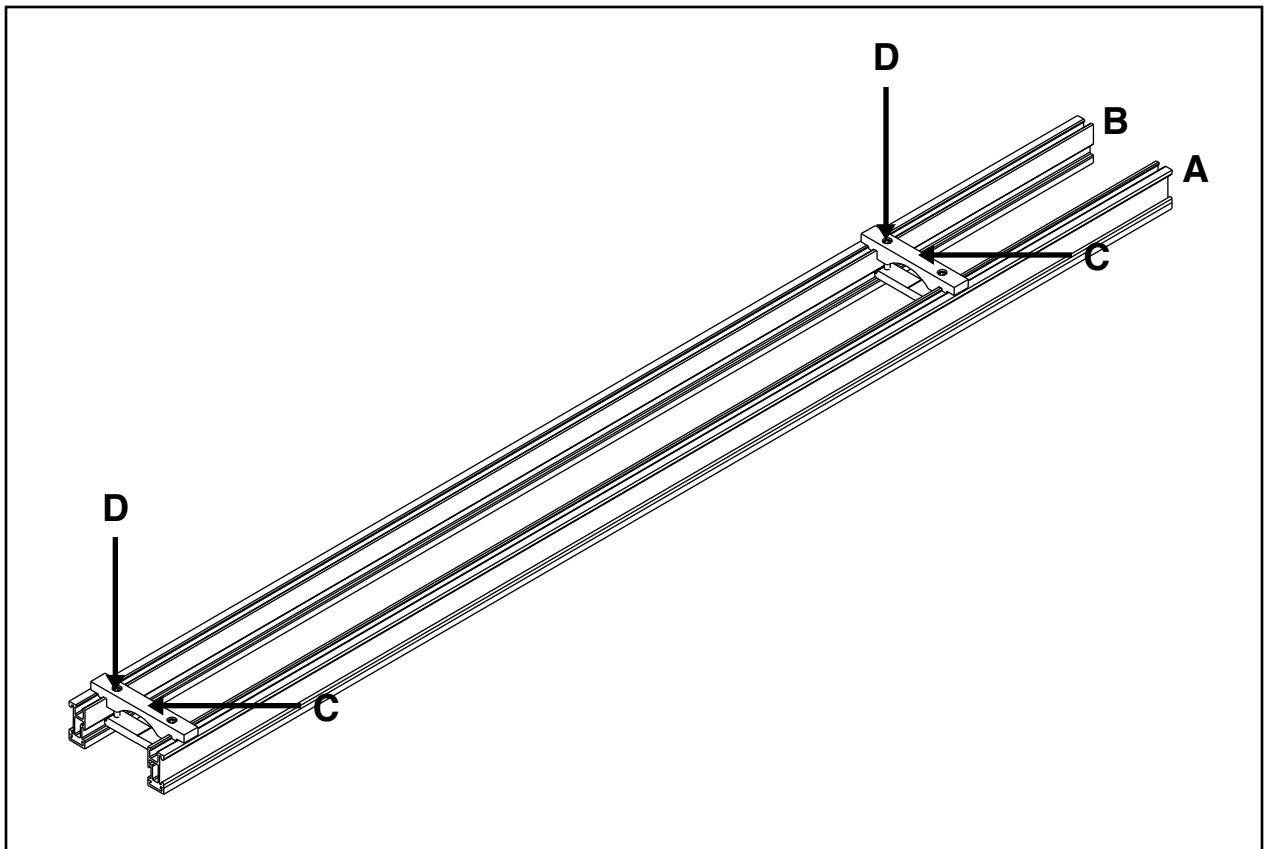

Rail Assembly Connector

The rail connector assembly is required to hold two Rail Assemblies together.

1. Slide the Rail Assembly (A) into the Connector Plate Assembly (B).
2. Tighten screws (C) lightly until connector plate is firmly seated.
3. Slide the other half of the Rail Assembly (D) into the Rail Connector Assembly (B).
4. Fully tighten screws.

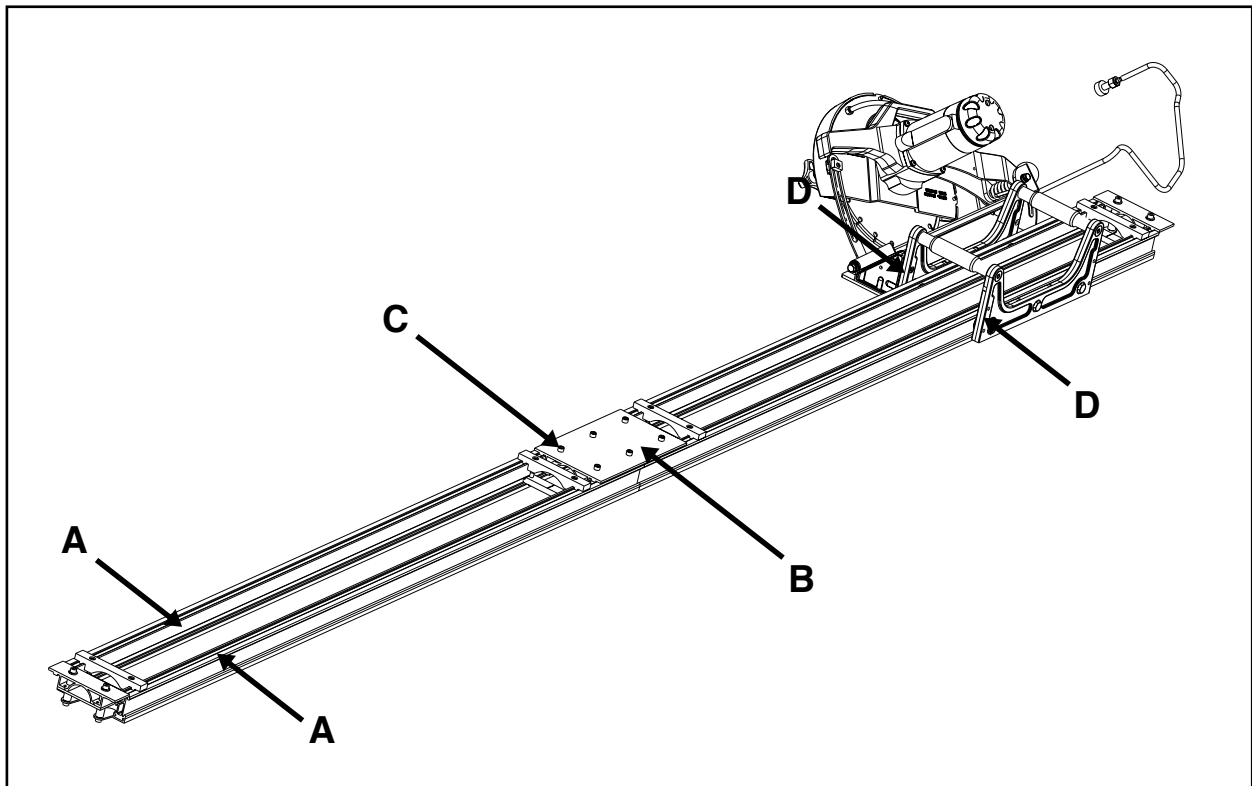

Cutting Head Assembly

The Cutting Head Assembly is pre-assembled and aligned at the factory.

WARNING

Ensure that the power is disconnected before installing the Cutting Head Assembly to Rails.

1. Place the Rail Assembly (B) on slab.
2. Slide the Cutting Head Assembly (A) until the Carrier Wheels (C) are over Rail Assembly (B).
3. Move the Cutting Head Assembly along the Rail Assembly with a sliding motion.

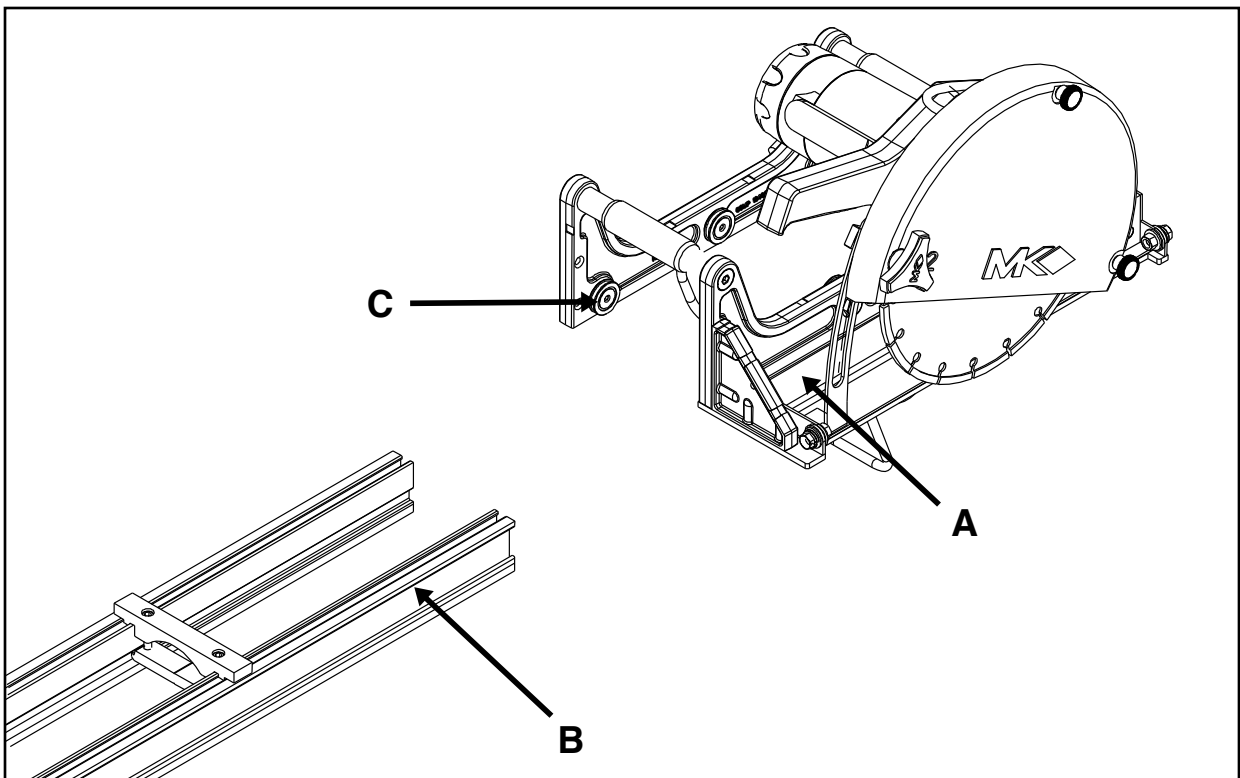

Material Clamps & Alignment

WARNING

Ensure that the electrical cord is not connected before assembling and aligning material clamps.

1. Position Saw Assembly (A) on the slab. The inner side of the blade is approximately 6.25 inches from the top edge of the aluminum rail.
2. Slide the Material Clamps from both ends of the Rail Assembly until the Clamp Foot (B) is underneath the slab.
3. Tighten screws (C) until the Saw Assembly is secured to the slab without any side movement.
4. To realign the Rail Assembly, slightly loosen the Material Clamps. Realign the Rail Assembly by tapping the ends of the Rail Assembly.
5. Repeat Steps 3 and 4 if realignment is necessary.

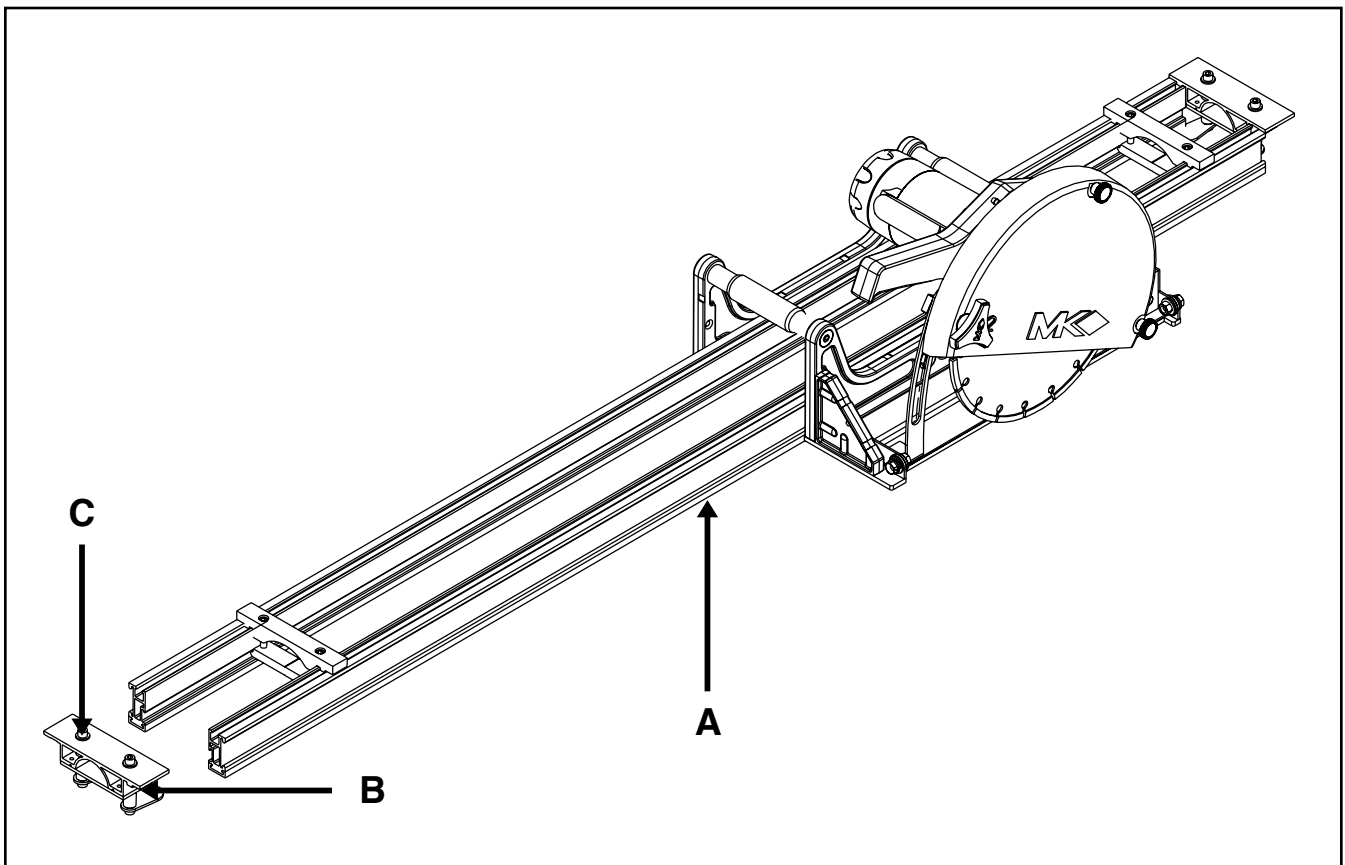

Hose Set-Up

1. Connect Plastic Fitting (A) to Nipple (B).
2. Connect Hose Fitting (C) to Water Hose.

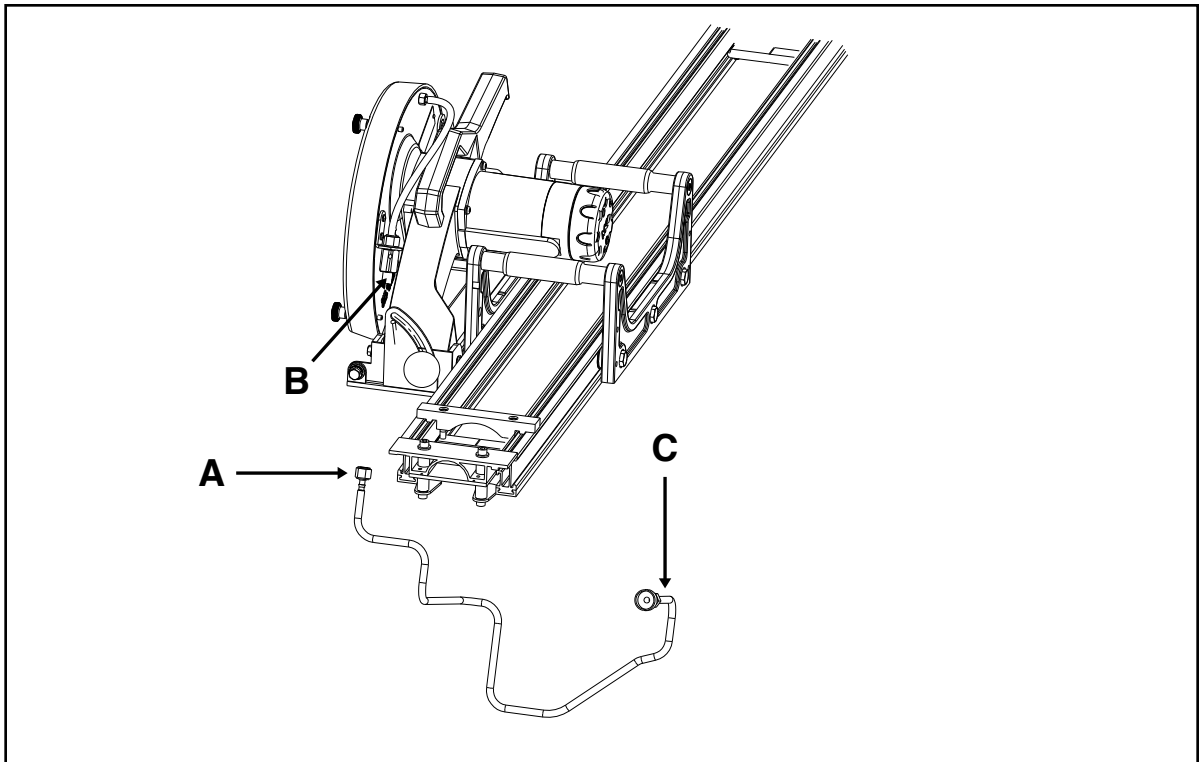

 **CAUTION**

Always use a Grounded Fault Circuit Interrupter (GFCI) with this saw.

Plunge Cutting for a 90° Cut

1. Loosen the Tri-Knob (A). Raise the blade to the highest position and move the Saw Assembly to the beginning of the cut.
2. Adjust the Valve (B) for the desired amount of water flow.
3. Depress motor switch and lower the blade slowly into the material.
4. Tighten the Tri-Knob (A) once the blade cuts through the material. Follow the direction of the cut.

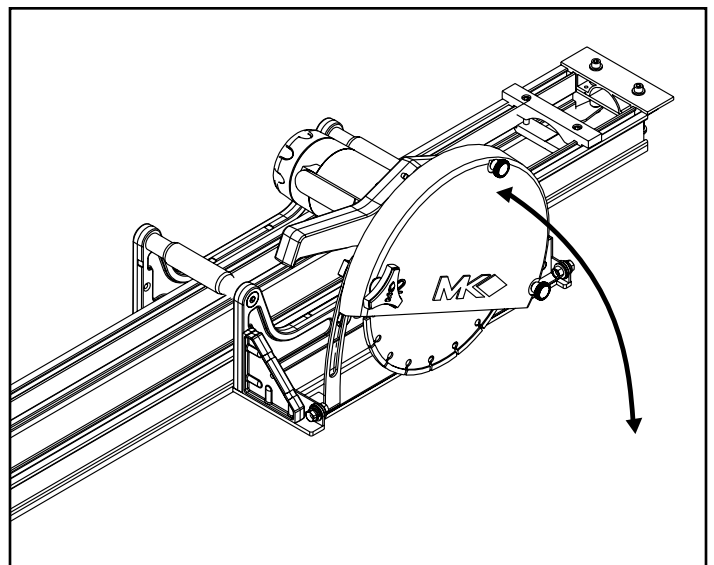
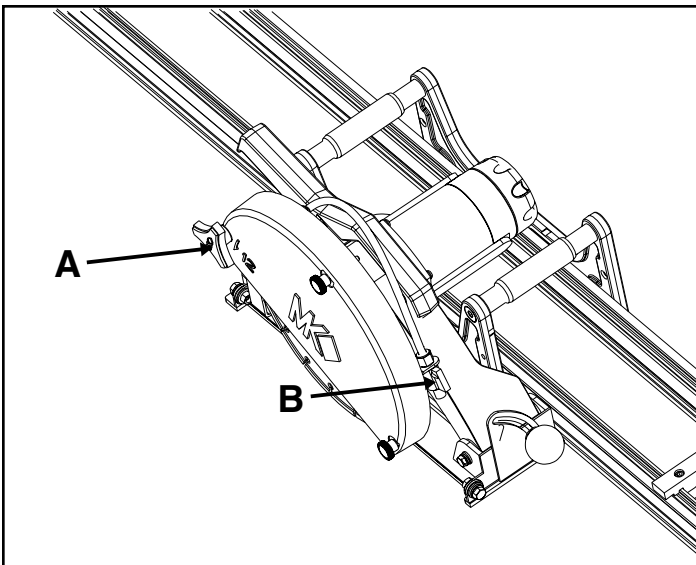

Plunge Cutting for a Miter Cut

1. Loosen the Round Knob (A) and adjust the blade to the desired angle (0-45 degrees). Tighten the Round Knob. Recheck the set angle along the entire rail system.
2. Loosen the Tri-Knob (B). Raise the blade to the highest position and move the Saw Assembly to the beginning of the cut.
3. Adjust the Valve (C) for the desired amount of water flow.
4. Depress motor switch and lower the blade slowly into the material.
5. Tighten the Tri-Knob (B) once the blade cuts through the material. Follow the direction of the cut.

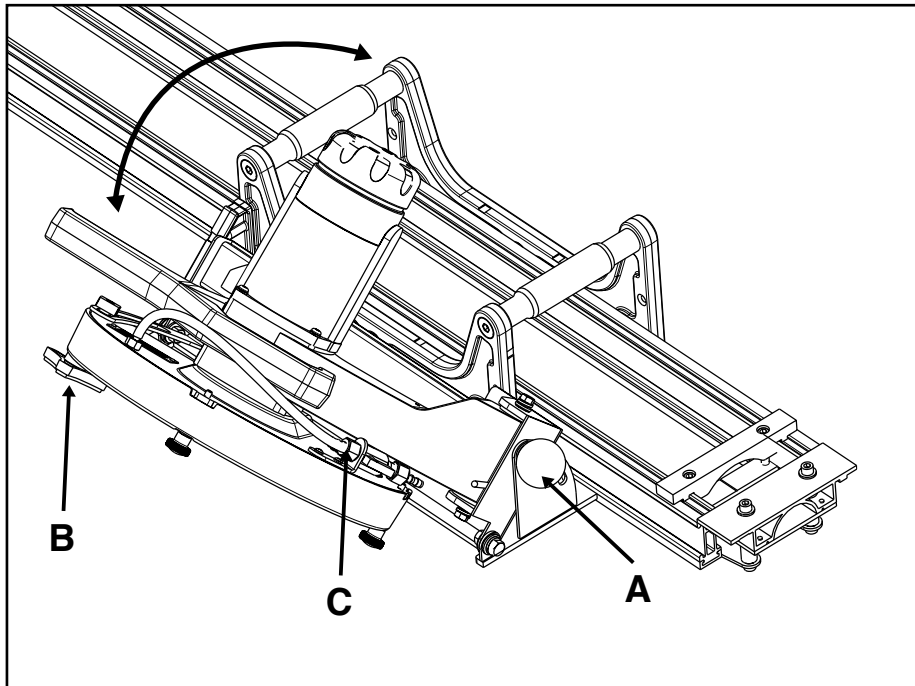

! **WARNING**

Always disconnect the unit from the power supply.

Blade Replacement

1. Remove knobs on outer blade guard.
2. Remove the Blade Guard.
3. Use the open wrenches provided with this unit. Place wrench (A) over the flats on blade shaft (located on the inner side of the blade). Hold the wrench stationary. Place wrench (B) on the Hex Screw at the end of the blade shaft. Turn wrench (B) counter-clockwise to remove the screw.
4. Replace the blade and ensure that the blade is oriented with the arrow in a counter clockwise position. Tighten the screw clockwise to secure the new blade.
5. Rotate the blade by hand to check it for tightness.

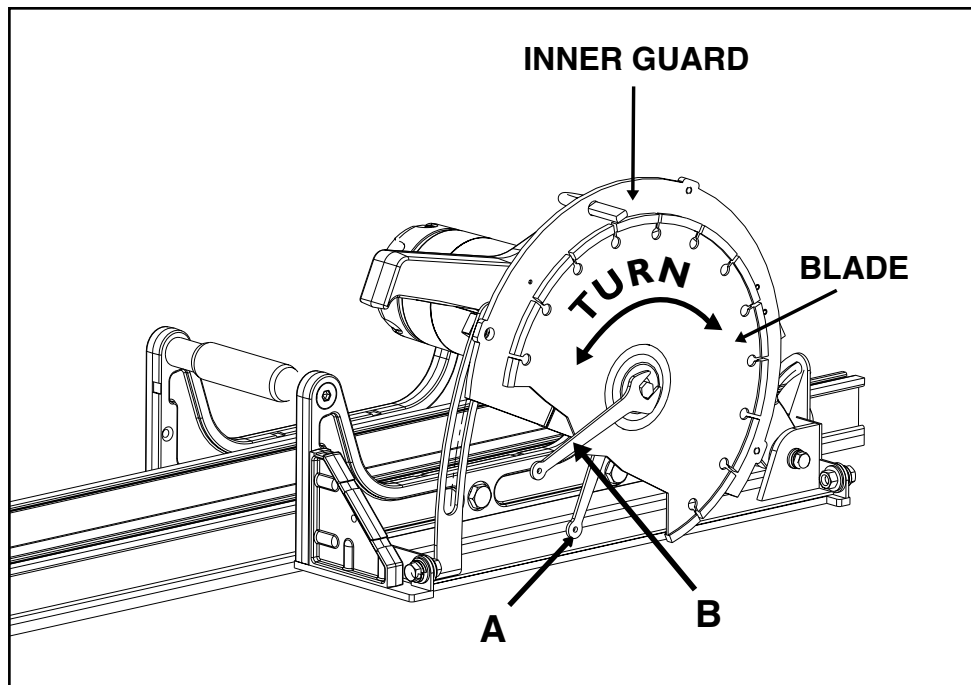

Filter Replacement

1. Pull Filter Cap (A) off.
2. Replace Filter.
3. Snap Filter Cap back on.

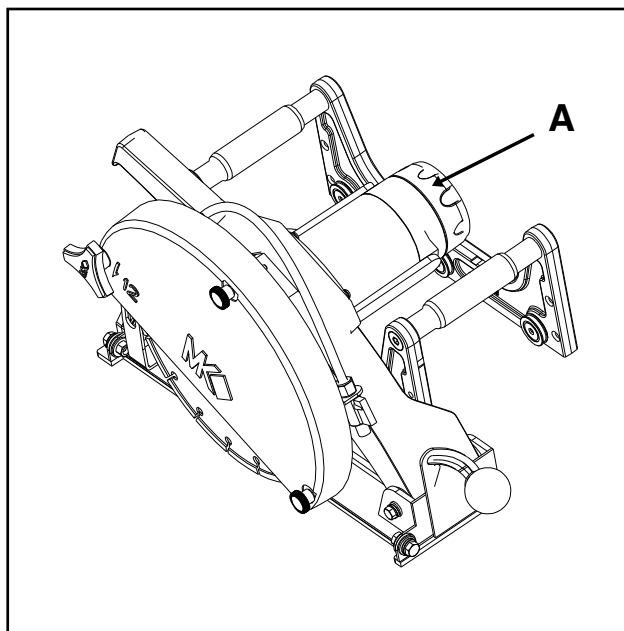

 **WARNING**

Disconnect the unit from the power supply.

Roller Wheel Replacement

1. Remove the Hex Screws (A) and Round Knob (B).
2. Remove Motor and Blade Guard Assembly from the Carrier Assembly.
3. Remove Carrier Assembly from the Rail Assembly. Place the Carrier Assembly on a flat and level surface.

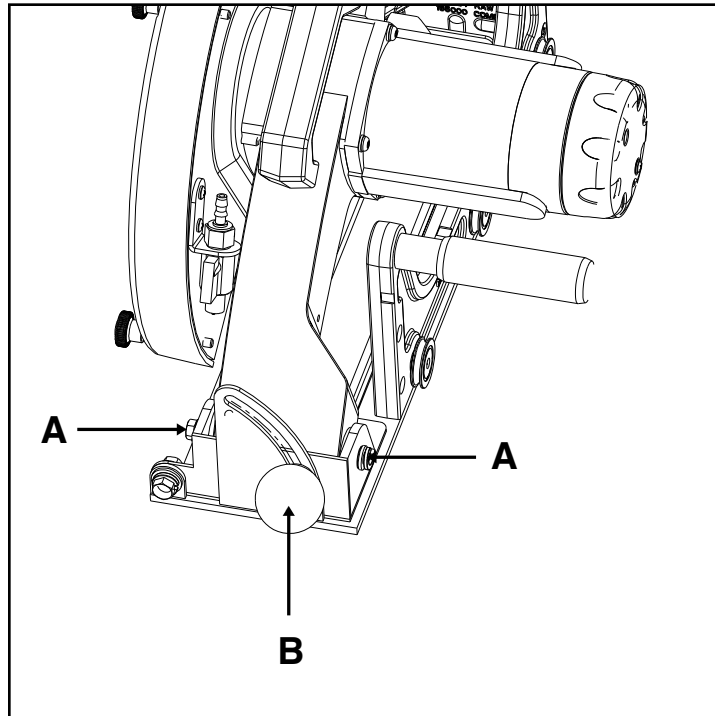

Roller Wheel Replacement Continued

1. Unscrew the wheel(s) with a 3/16 hex key. Ensure that the eccentric bushings (A) and straight bushings (C), located in the middle of each carrier casting, do not move.
2. Install new wheels by screwing into bushings.
3. Slide the Carrier Assembly back in the rail to check for wheel alignment.
4. If carrier assembly does not line up with rails, loosen set screw(s) (B) located on the bottom of carrier legs.
5. Align straight bushing(s) (C) so groove on wheel is centered on rail rib. Hold bushing in place while tightening set screw. **DO NOT FULLY TIGHTEN AT THIS TIME.**

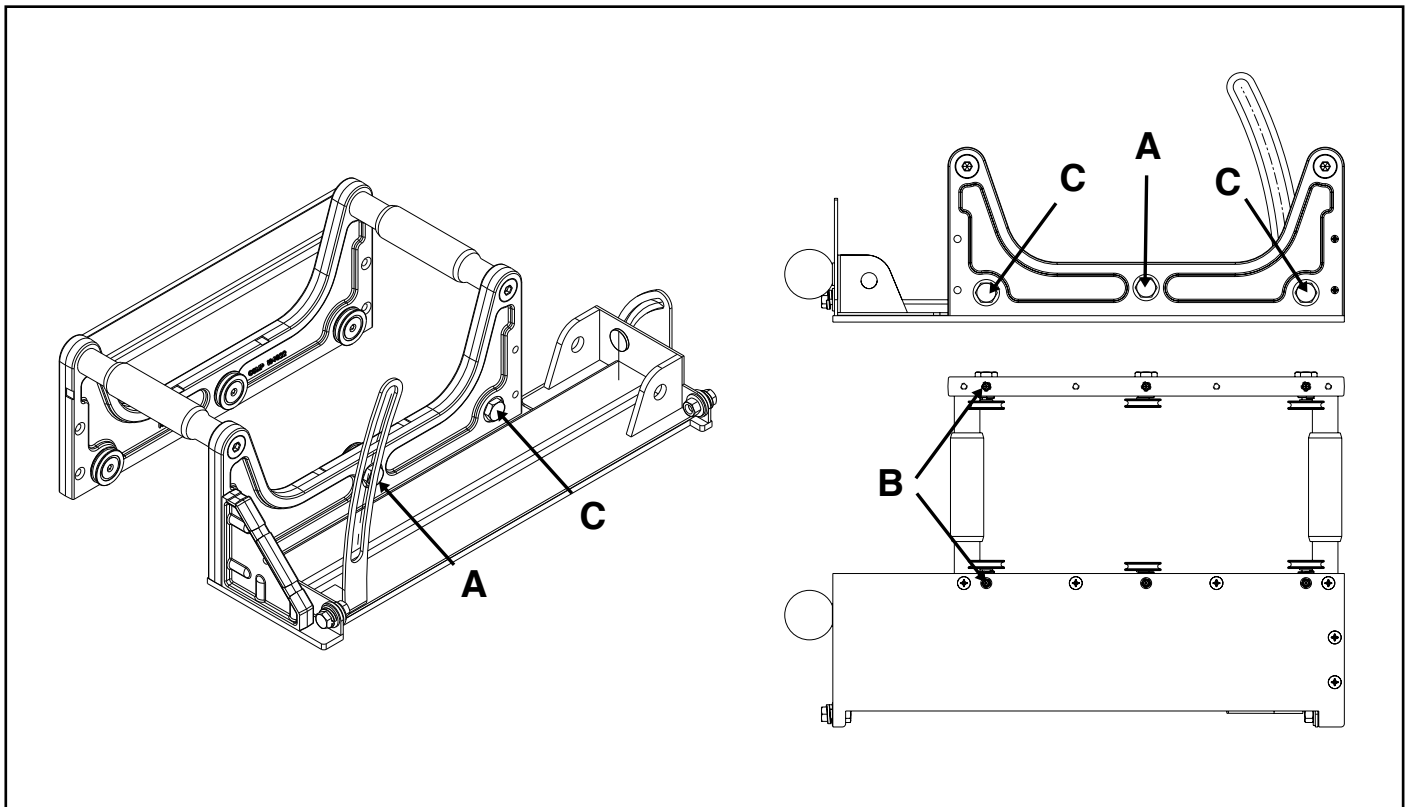

Roller Wheel Replacement Continued

1. Position eccentric bushing(s) (A) until the groove on the wheel lines up with the center of the rail rib. Turn the eccentric bushing(s) (A) until the radial groove of the wheel touches lightly with the top of the rail rib. Hold the eccentric bushing(s) stationary while tightening down set screw(s) (B) lightly. Groove aligns with center of upper rail rib. Turn eccentric bushing until wheel groove lightly contacts upper rail rib. Hold eccentric bushing in place while tightening set screws. **DO NOT FULLY TIGHTEN AT THE TIME.**
2. Repeat Steps 7 through 10, if necessary.
3. Tighten all set screws (B).
4. Reinstall the motor and blade guard assembly.
5. Recheck for wheel alignment and smoothness of travel.

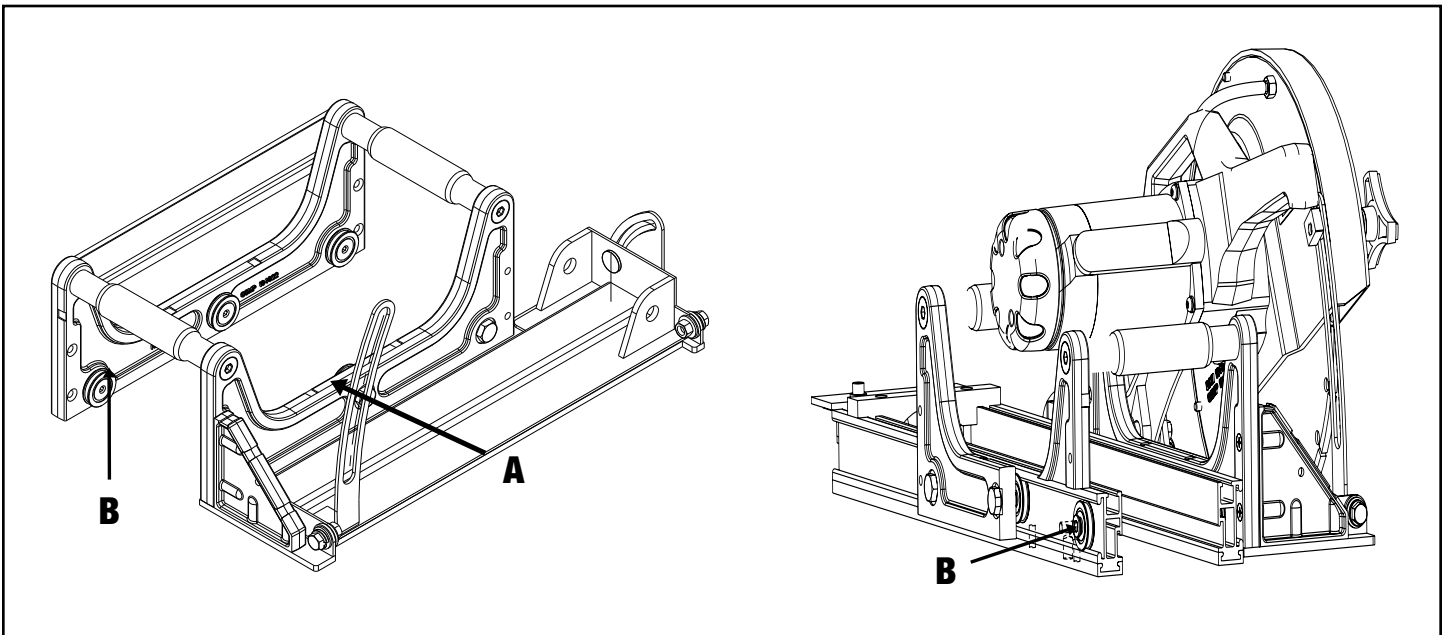

Final Assembly

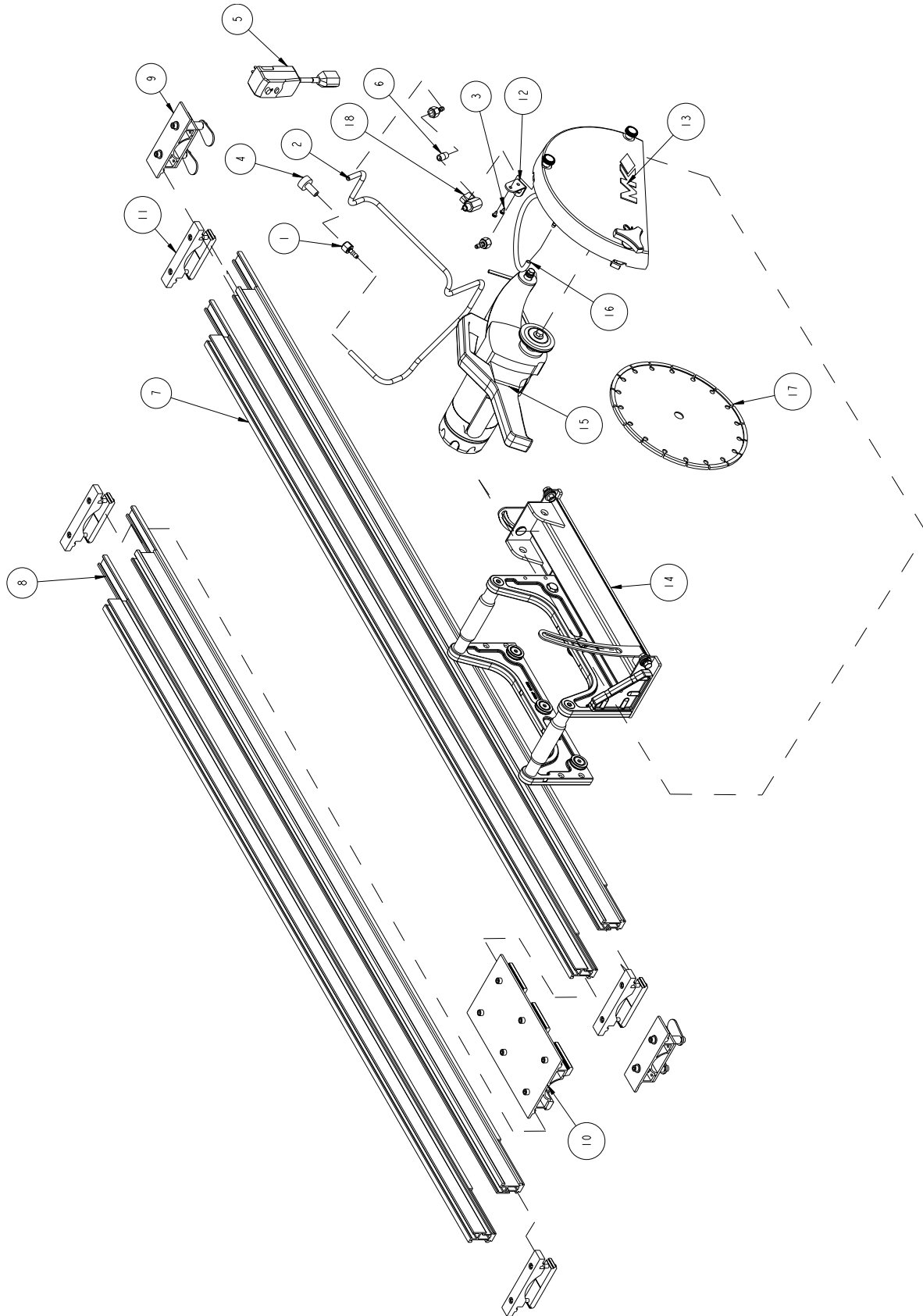

Final Assembly

ITEM NO.	DESCRIPTION	PART #	QTY.
1	FITTING, PLASTIC, 1/4 FNPT X 1/4 BARB	128397	3
2	HOSE, VINYL, 3/8 X 1/4 X 6 FT	132951	1
3	SCREW, PAN HD SELF TP10-24 X 3/8	151262	2
4	FITTING, HOSE, 1/4 MNPT	152525	1
5	GFCI, 120V, 15A	152610	1
6	NIPPLE, 1/4 NPT X CLOSE, BRASS	159905	1
7	RAIL, TRACK SAW	164926	4
8	FOOT, RAIL	164944	4
9	CLAMP, RAIL SAW MATERIAL	165113	2
10	ASSY, RAIL CONNECTOR PLATE	165268	1
11	ASSY, PARALLEL RAIL SUPPORT BRACKET	165269	4
12	BRACKET, WATER VALVE	165478	1
13	ASSY, BLADE GUARD	165499	1
14	ASSY, MAIN CARRIER	165500	1
15	ASSY, CUTTING HEAD	165501	1
16	HOSE, 3/8 X 1/4 X 10"	165506	1
17	BLADE, 12"	165921	1
18	VALVE, BALL, 1/4"M TO 1/4"F	231248	1

Main Carrier Assembly

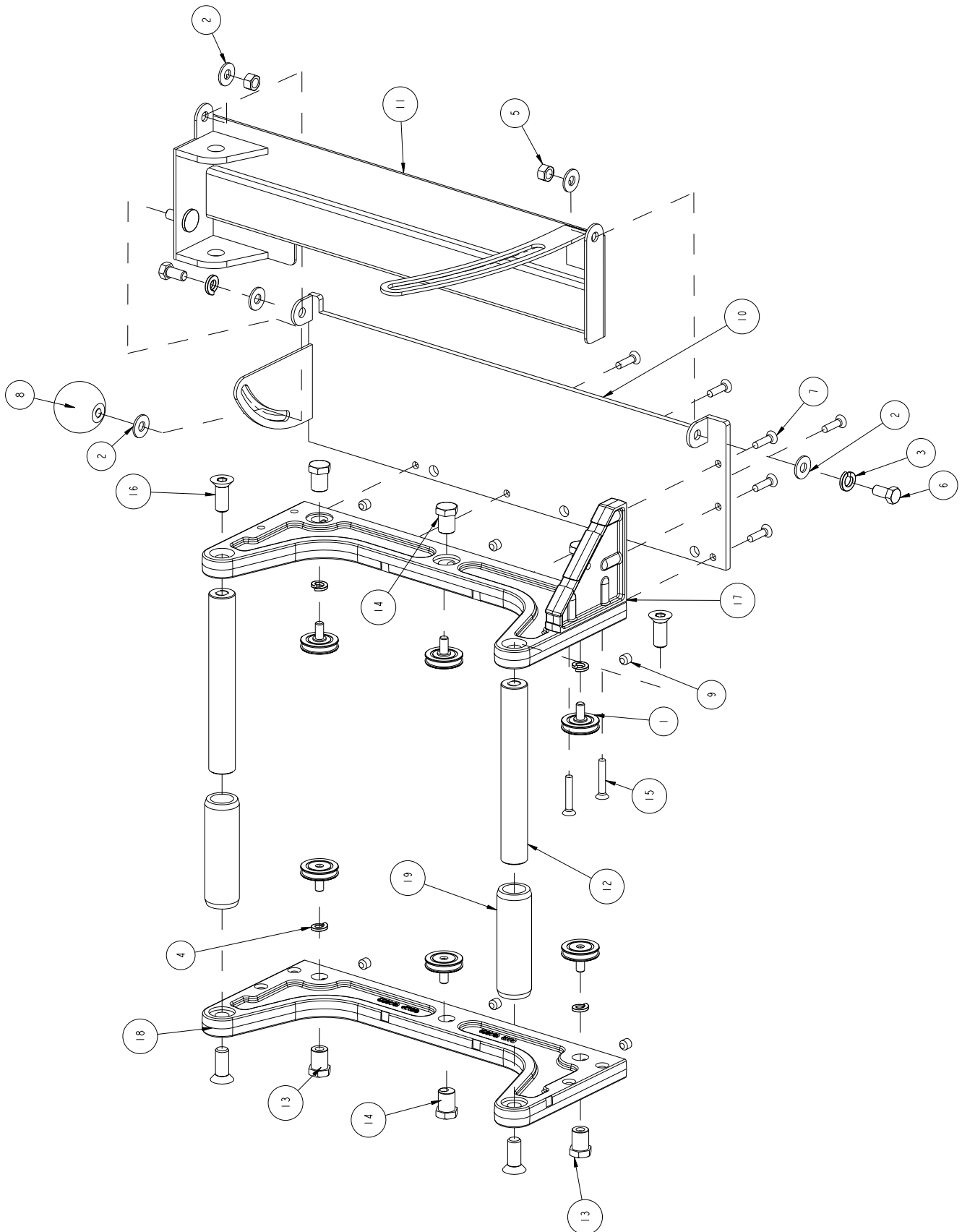

Main Carrier Assembly

ITEM NO.	DESCRIPTION	PART #O.	QTY.
1	WHEEL, CONVEYOR CART	133090	6
2	WASHER, 3/8 SAE FLAT	150923	5
3	WASHER, 3/8 SPLIT LOCK	150925	2
4	WASHER, 5/16 SPLIT LOCK	151747	4
5	NUT, 3/8-16 HEX CENTERLOCK	153522	2
6	SCREW, 3/8-16 X 3/4 HEX HEAD CAP	153527	2
7	SCREW, 1/4-20 X 3/4 FLAT HEAD PHILLIPS MACHINE	154657	6
8	KNOB, BALL, 2", 3/8-16 INSERT	158519	1
9	SCREW, 3/8-16 X 3/8 SOCKET HEAD SET, CUP POINT	160713	6
10	BASE, INNER PIVOT	164923	1
11	BASE, TRACK RAIL SAW PIVOT	164925	1
12	SUPPORT, TRACK RAIL CROSS	164931	2
13	AXLE, CONVEYOR WHEEL	164932	4
14	AXLE, ADJ CONVEYOR WHEEL	164933	2
15	SCREW, 1/4-20 X 3/4 FLAT HEAD PHILLIPS MACHINE	165120	2
16	SCREW, 1/2-13 X 1-1/4 FLAT HEAD	165164	4
17	GUSSET (COMP)	166112	1
18	CARRIER, CART WHEEL (COMP)	166114	2
19	GRIP, HANDLE	229413	2

Cutting Head Assembly

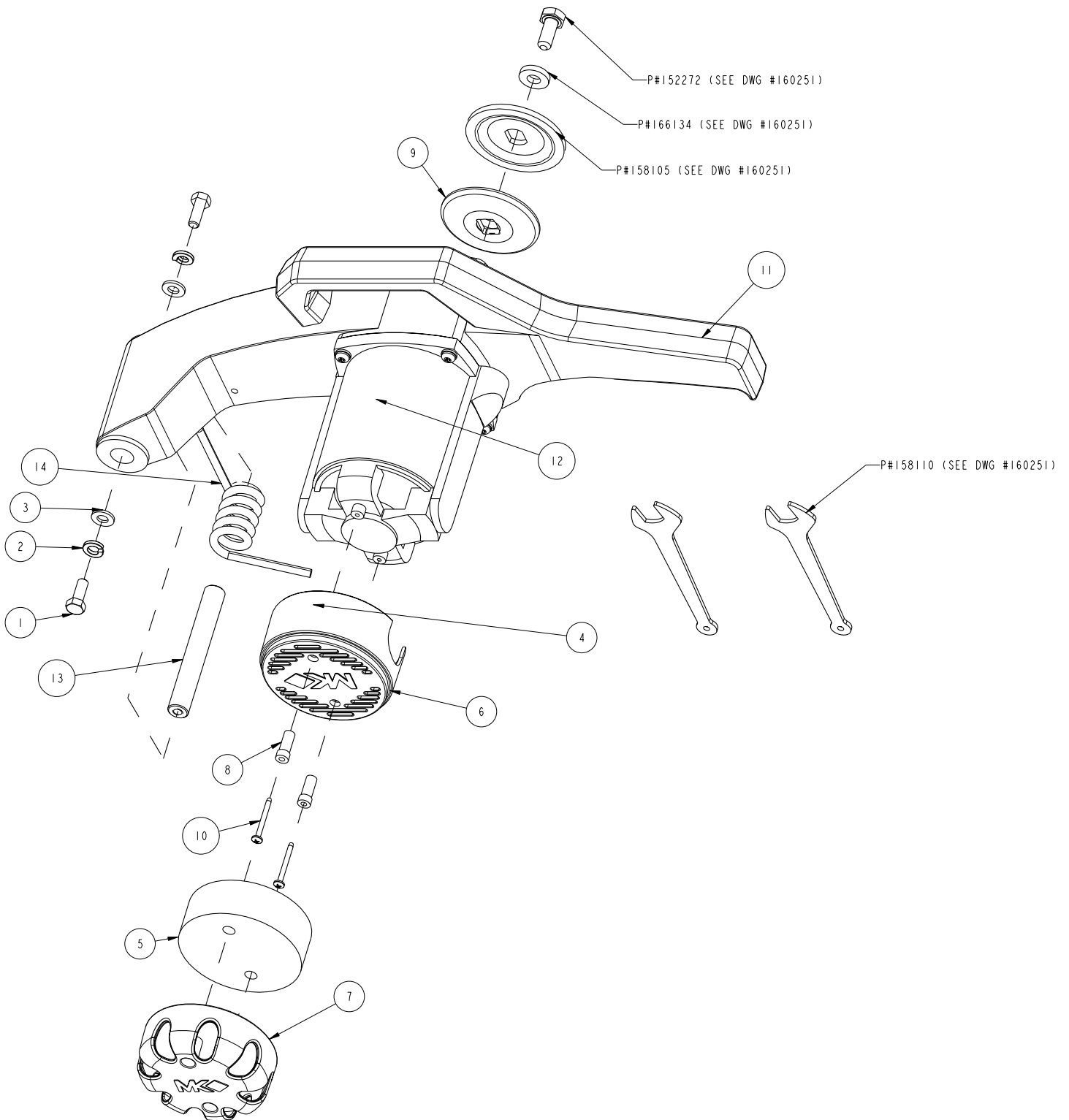

Cutting Head Assembly

ITEM NO.	DESCRIPTION	PART #	QTY.
1	SCREW, 5/16-18 X 1 HEX HEAD MACHINE	151743	2
2	WASHER, 5/16 SPLIT LOCK	151747	2
3	WASHER, 5/16 SAE FLAT	151754	2
4	LABEL, CAUTION, SAFETY	155576	1
5	FILTER, MOTOR	157729	1
6	CAP, MOTOR	157877	1
7	SPACER, NYLON	157878	1
8	SPACE, CAP SCREW	157879	2
9	FLANGE, Ø 3.0 INNER	158106	1
10	SCREW, #8 X 1-1/2 FLAT HD PHIL	158157	2
11	ASSY, MOTOR, 115V/3A	160251	1
12	LABEL, WARNING, SILICA, PROP 65	164202	1
13	PIN, PIVOT	164934	1
14	SPRING, 70' TORSION	165272	1

Blade Guard Assembly

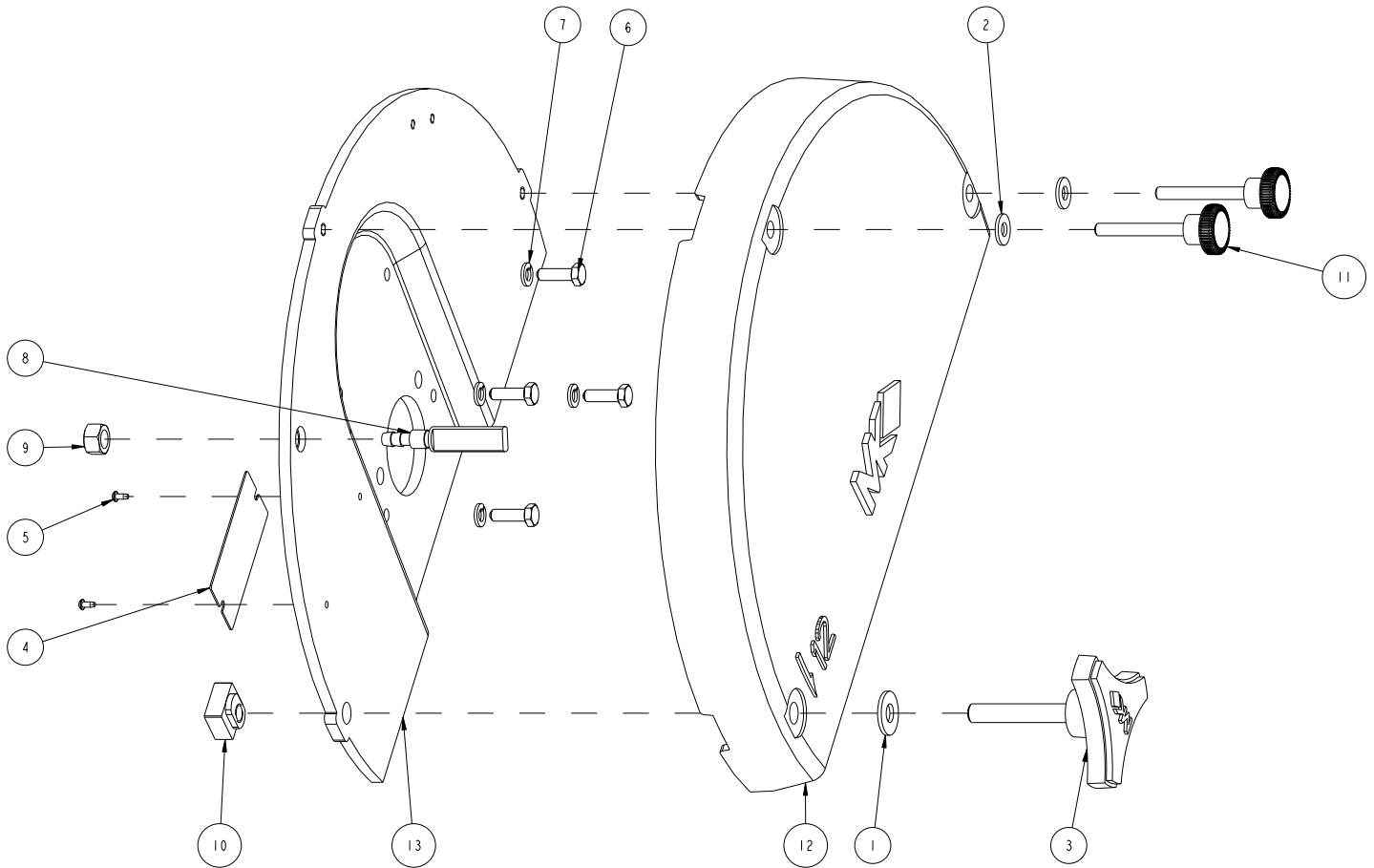

ITEM NO.	DESCRIPTION	PART #	QTY.
1	WASHER, 3/8 SAE FLAT	150923	1
2	WASHER, 1/4 SAE FLAT	151915	2
3	KNOB, TRI PLASTIC, 3/8-16X2-1/4	56770-04	1
4	TAG, SERIAL #, BLANK	157500	1
5	DRIVE SCREW, #7 X 5/16 ROUND HEAD	157849	2
6	SCREW, HEX HEAD CAP, M6 X 1 X 20MM	158158	4
7	WASHER, SPLIT LOCK, M6	158159	4
8	MANIFOLD, WATER	159854	1
9	NUT, 3/8-16 HEX	159863	1
10	NUT, ROUNDED T-SLOT	164945	1
11	KNOB, 1/4-20X2 ROUND	165163	2
12	GUARD, BLADE (COMP)	166109	1
13	GUARD, INNER BLADE (COMP)	166111	1

Parallel Rail Support Bracket

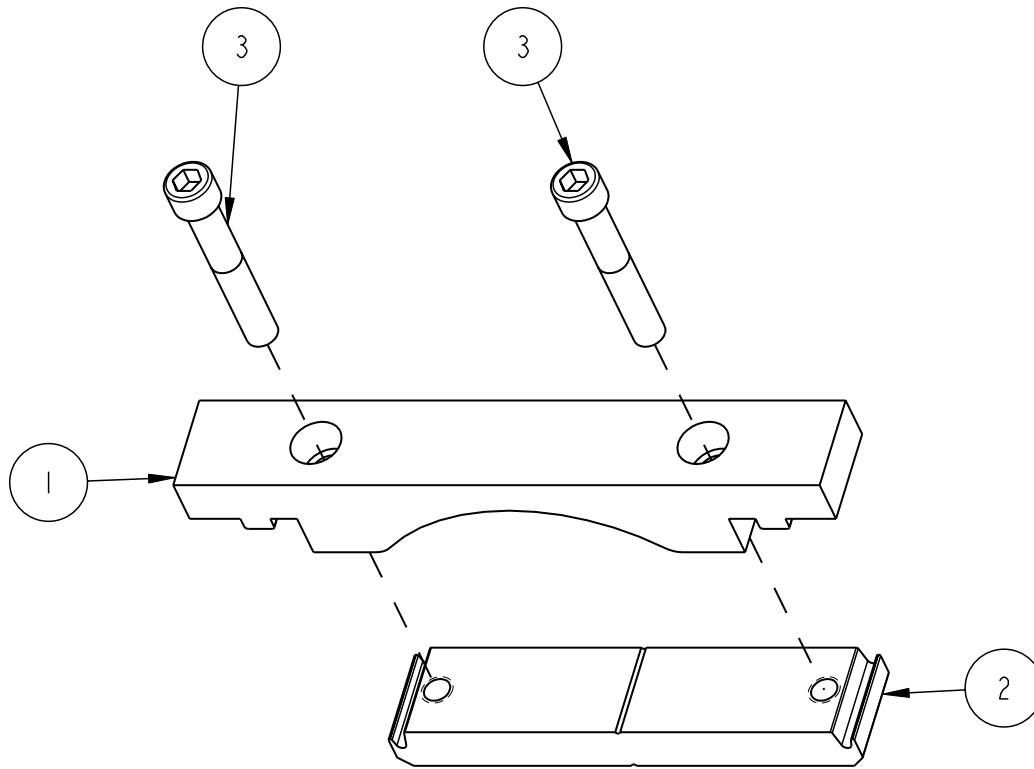

ITEM NO.	DESCRIPTION	PART #	QTY.
1	CLAMP, UPPER RAIL	164939	1
2	CLAMP, LOWER RAIL (COMP)	164942	1
3	SCREW, 5/16-18X2 SOCKET HEAD CAP	165165	2

Rail Connector Plate

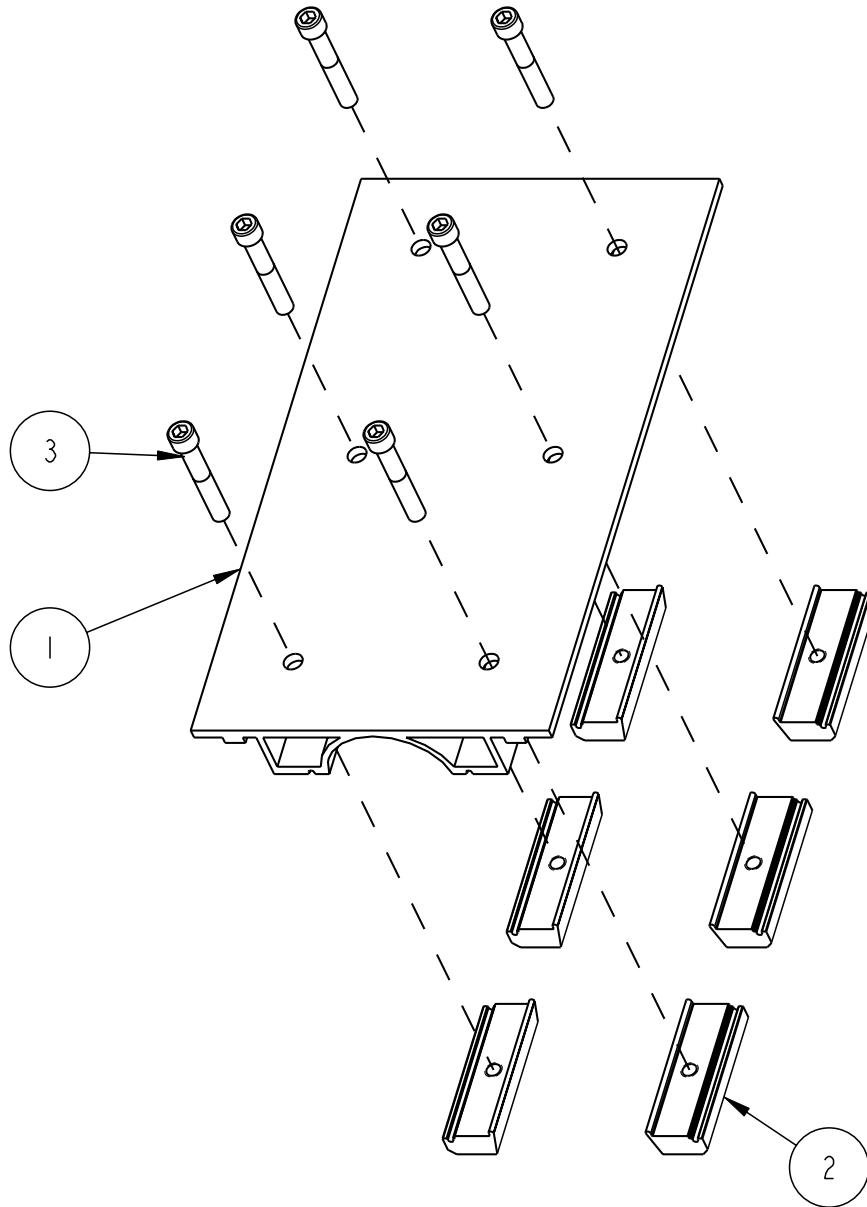

ITEM NO.	DESCRIPTION	PART #	QTY.
1	PLATE, RAIL CONNECTOR	164936	1
2	SHOE, CONNECTOR (COMP)	164938	6
3	SCREW, 5/16-18X2 SOCKET HEAD CAP	165165	6

Rail Saw Material Clamp

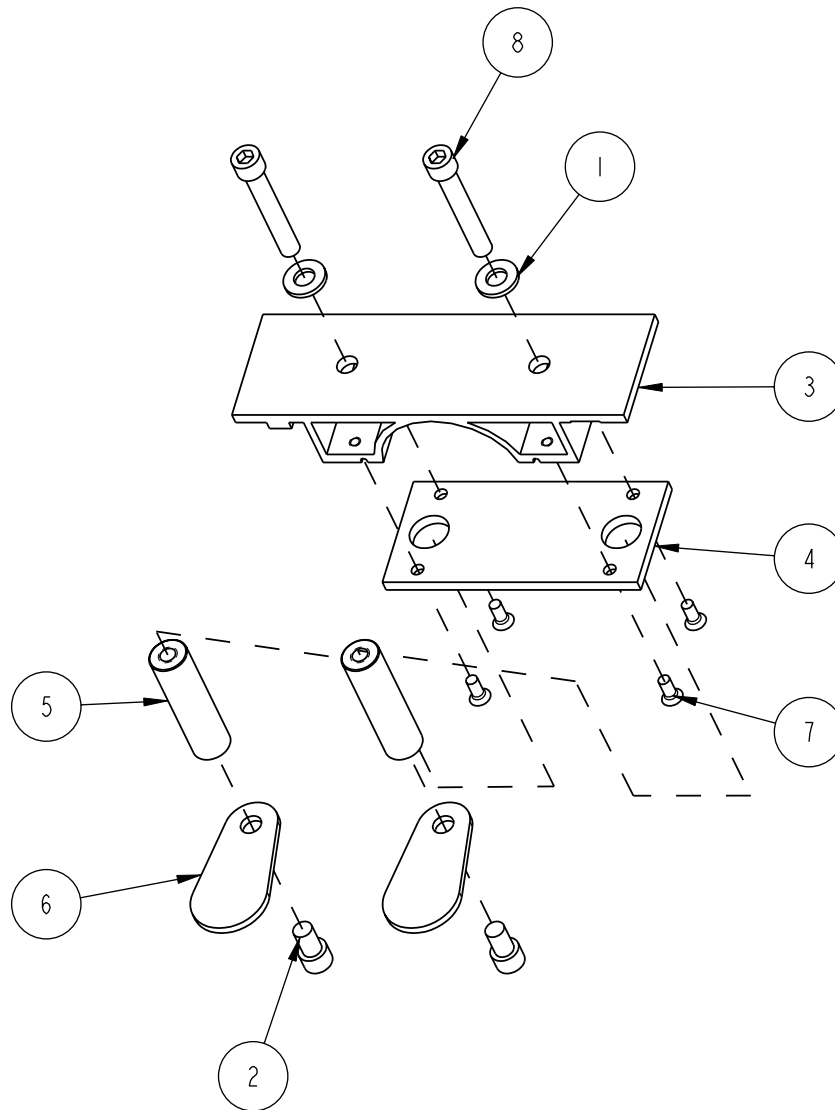

ITEM NO.	DESCRIPTION	PART #	QTY.
1	WASHER, 5/16 SAE FLAT	151754	2
2	SCREW, 5/16-18X1/2 SOCKET HEAD CAP	156139	2
3	BASE, MATERIAL CLAMP	165114	1
4	PLATE, MATERIAL CLAMP SUPPORT	165115	1
5	STAND-OFF, THREADED	165116	2
6	FOOT, MATERAL CLAMP	165117	2
7	SCREW, 10-24 X 3/4 FLAT HEAD PHILLIPS MACHINE	165121	4
8	SCREW, 5/16-18 X 2 SOCKET CAP	165243	2

ORDERING INFORMATION

You may order MK Diamond products through your local MK Diamond distributor or, you may order direct from MK Diamond.

When ordering direct from MK Diamond, please have the following information ready before calling:

- The Model Number of the saw
- The Serial Number of the saw
- Where the saw was purchased and when
- The Part Number for the part(s) being ordered
- The Part Description for the part(s) being ordered

NOTE: There is a \$25.00 minimum order when ordering direct from MK Diamond. A \$6.00 charge will be added to orders having a net billing value under \$50.00. All purchases must be made using VISA, MasterCard or American Express.

All parts may be ordered by calling toll free to – 800 421-5830 or 310 539-5221 and asking for Customer Service. For technical questions, call – 800 474-5594.

RETURN MATERIALS POLICY

To expedite the service relative to the return of a product purchased through MK Diamond, please observe the following:

NOTE: When returning all items, they must have been purchased within the previous twelve (12) months.

- Have the Model Number of the saw
- Have the Serial Number of the saw
- Have the location of where the saw was purchased
- Have the date when the saw was purchased
- Contact Customer Service for approval to return the item(s)
- Obtain a Returned Goods Number (RGA) authorizing the return
- Follow the packaging instructions in the following section
- Ensure your item(s) are prepaid to the destination

For returned items, call toll free to – 800 421-5830 or 310 539-5221 and ask for Customer Service. For technical questions, call – 800 474-5594 or 310 257-2845.

PACKAGING INSTRUCTIONS

- Remove the Cutting Head and Support Angle Assembly
- Dry the saw before shipping
- When packing, include the following: Saw, Diamond Blade, Blade Guard and Support Angle Assembly and Adjustable Cutting Guide (Other Accessories are not required)
- Package the unit in its original container or one of comparable size (do not ship the unit partially exposed)
- Ensure all parts are secured in the packaging to prevent moving

AUTHORIZED SERVICE CENTERS

For quicker repair time, you may contact MK Diamond Customer Service, toll free, at 800 421-5830 or 310 539-5221 for the Authorized Service Center closest to you or visit our web site at www.mkdiamond.com. For technical questions, call – 800 474-5594.

CONTACT:

Please contact MK Diamond Products, Inc. Customer Service Department with any questions you might have regarding distributors, parts or service.

Telephone: **(800) 421-5830**

Fax: **(310) 539-5158**

E-mail: **Customer_Service@MKDiamond.com**

Customer Service Hours: **Monday through Friday, 6AM-4PM PST**

MK Diamond Products, Inc.

1315 Storm Parkway

Torrance, CA 90501

MK DIAMOND PRODUCTS, INC. LIMITED WARRANTY

MK DIAMOND PRODUCTS, INC. will guarantee every machine they build, to be free from defects in material and workmanship for (1) one year from date of purchase. The obligation of MK DIAMOND PRODUCTS, INC. under this warranty is limited to the repair or replacement of any parts which, under normal use, prove to be defective in material or workmanship. The parts involved or the unit in question should be returned to MK DIAMOND PRODUCTS, INC. or to a point designated by us, transportation prepaid.

This warranty does not obligate us to bear the cost of labor or transportation charges in connection with replacement or repair of defective parts. Likewise, it shall NOT apply to any unit which has been subjected to misuse, neglect or accident. This warranty does NOT apply to any machine which has been repaired or altered outside our factory.

This warranty does NOT obligate MK DIAMOND PRODUCTS, INC., with respect to items not of our manufacture, such as engines, motors, hydraulics, etc., which are subject to their own guarantees and warranties.

We shall in no event be liable for consequential damages or contingent liabilities arising out of failure of any equipment or parts to operate properly.

© COPYRIGHT 2015, MK DIAMOND PRODUCTS, INC. ALL RIGHTS RESERVED.

The MK Diamond logo is a registered trademark of MK Diamond Products, Inc. and may not be used, reproduced, or altered without written permission. All other trademarks are the property of their respective owners and used with permission.

MK Diamond may have patents, patent applications, trade marks, copyrights of other intellectual property right covering this product in this document.

This manual MUST accompany the equipment at all times. This manual is considered a permanent part of the equipment and should remain with the unit if resold.

The information and specifications included in this publication were in effect at the time of approval for printing.

**MK DIAMOND TRACK RAIL SAW
OPERATION & PARTS MANUAL**



MK Diamond Products, Inc.

MK Diamond Products, Inc.
1315 Storm Parkway
Torrance, CA 90501

Toll-Free: (800) 421-5830
Phone: (310) 539-5221
Fax: (310) 539-5158
www.mkdiamond.com