

**NORTON**

**clipper**

C35 Series 11/2013

# SELF PROPELLED SAW SERIES OPERATOR'S MANUAL

## **C35 VANGUARD GASOLINE SERIES**

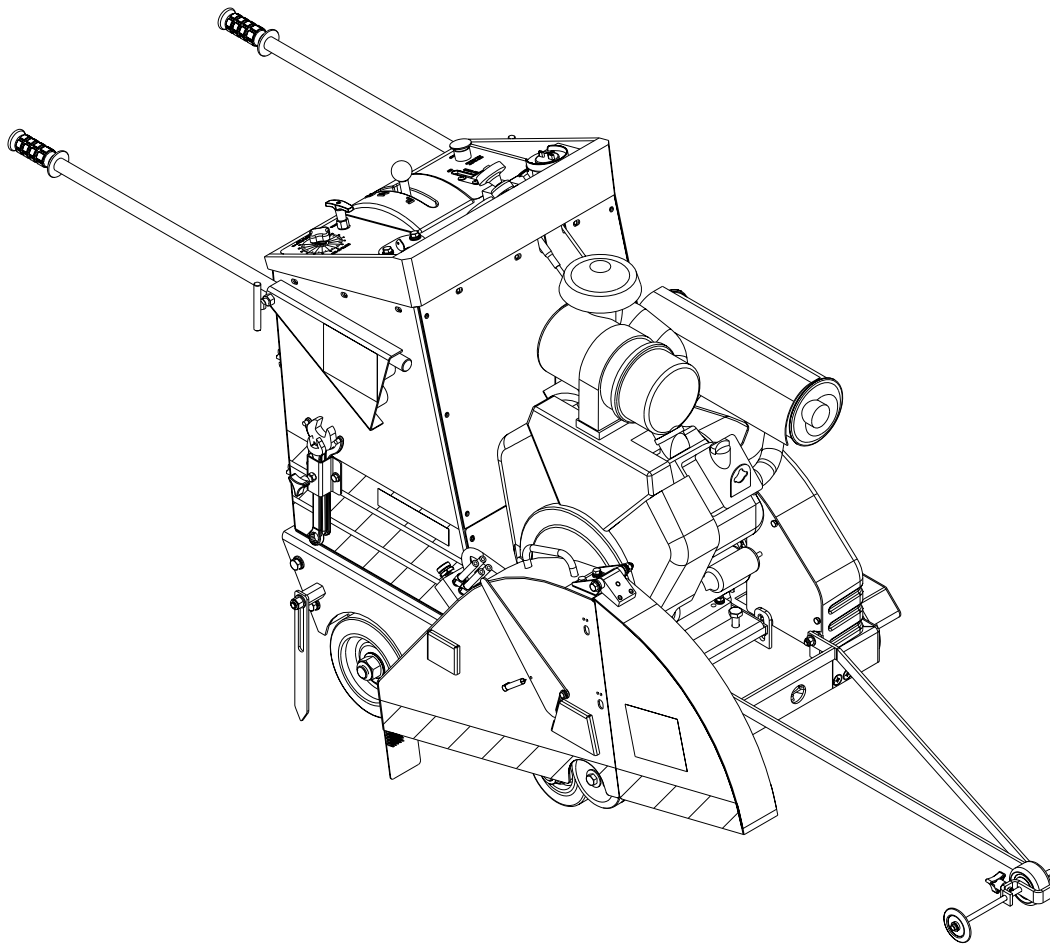

**CAUTION:** Read all safety and operating instructions before using this equipment. This manual **MUST** accompany the equipment at all times.

Revision: 101 11/2013  
Manual Part# 168497-OM

[www.nortonconstructionproducts.com](http://www.nortonconstructionproducts.com)

## INTRODUCTION

Congratulations on your purchase of a C35 Self Propelled Flat Saw. We are certain that you will be pleased with your purchase. Norton Clipper takes pride in producing the finest construction power tools and diamond blades in the industry.

Operated correctly, your C35 Self Propelled Flat Saw should provide you with years of service. In order to help you, we have included this manual. This owners manual contains information necessary to operate and maintain your C35 Self Propelled Flat Saw safely and correctly. Please take the time to familiarize yourself with the C35 Self Propelled Flat Saw by reading and reviewing this manual.

Read and follow all safety, operating and maintenance instructions.

If you should have questions concerning your C35 Self Propelled Flat Saw, please feel free to call our friendly customer service department at: (254) 918-2310.

Regards,



### NOTE THIS INFORMATION FOR FUTURE USE:

<b>MODEL NUMBER:</b>	
<b>SERIAL NUMBER:</b>	
<b>PURCHASE PLACE:</b>	
<b>PURCHASE DATE:</b>	

**SAFETY**

Safety Message/Alert Symbols	4
Safety Warnings	5
Rules for Safe Operation	6-7
Operation & Safety Decals	8
Safety Decal Locations	9
Console Decal Locations	10
Console Control Descriptions	11

**PRODUCT SPECIFICATIONS**

Saw Features	12
Engine Specifications	13
Model Specifications	14
Saw Specifications	14

**INSPECTION & START-UP**

Pre-Operation Checklist, Schedule Maintenance Quick Reference	15
---	----

**OPERATION**

Blade Mounting Instructions	16-17
Starting Engine, Starting Instructions	18
Saw Guide Alignment and Adjustment, Pointer Alignment	19
Maneuvering the Saw, Dry Cutting, Wet Cutting, Speed Control-Lever Use and Adjustment	20
Engaging the Drive Unit, Water Hook Up and Depth Indicator	21

**MAINTENANCE**

Engine, Hydrostatic Drive Unit, Air Cleaner, Bearings and Hydrostatic Drive Unit	22
Maintenance Schedule	23
Troubleshooting	24

**GENERAL PRODUCT INFORMATION**

Step Cutting	25
Contact Information and Limited Warranty	27

Safety precautions should be followed at all times when operating this equipment. Failure to read and understand the Safety Precaution and Operating Instructions could result in injury to yourself and others.

This Operation and Parts Manual has been developed to provide complete instructions for the safe and efficient operation of the Norton Clipper Self Propelled Flat Saw.

Before using this machine, ensure that the person operating the machine has read and understands all instructions in this manual.

### **SAFETY MESSAGE / ALERT SYMBOLS**

---

A safety message alerts you to potential hazards that could hurt you or others. Each safety message is preceded by a safety alert symbol (  ) and one of three words: **DANGER**, **WARNING**, or **CAUTION**.



#### **DANGER**

You **WILL** be **KILLED** or **SERIOUSLY INJURED** if you do not follow directions.



#### **WARNING**

You **CAN** be **KILLED** or **SERIOUSLY INJURED** if you do not follow directions.



#### **CAUTION**

You **CAN** be **INJURED** if you do not follow directions. It may also be used to alert against unsafe practices.

Each message tells you what the hazard is, what can happen, and what you can do to avoid or reduce injury. Other important messages are preceded by the word **NOTICE**.



#### **NOTICE**

You can cause **PROPERTY DAMAGE** to your machine if you don't follow directions.

The safety labels should be periodically inspected and cleaned by the user to maintain good legibility at a safe viewing distance. If the label is worn, damaged or illegible, it should be replaced.

## SAFETY WARNINGS

---

### SILICA DUST WARNING

Grinding/cutting/drilling of masonry, concrete, metal and other materials can generate dust, mists and fumes containing chemicals known to cause serious or fatal injury or illness, such as respiratory disease, cancer, birth defects or other reproductive harm. If you are unfamiliar with the risks associated with the particular process and/or material being cut or the composition of the tool being used, review the material safety data sheet and/or consult your employer, the material manufacturer/supplier, governmental agencies such as OSHA and NIOSH and other sources on hazardous materials and make certain to comply with all product warnings and instructions for the safe and effective use of the material being cut. California and some other authorities, for instance, have published lists of substances known to cause cancer, reproductive toxicity, or other harmful effects.

Control dust, mist and fumes at the source where possible. In this regard use good work practices and follow the recommendations of the manufacturer/supplier, OSHA/NIOSH, and occupational and trade associations. Water should be used for dust suppression when wet cutting is feasible. When the hazards from inhalation of dust, mists and fumes cannot be eliminated through engineering controls such as vacuum and/or water mist, the operator and any bystanders should always wear a respirator approved by NIOSH/MSHA for the material being cut.

### CALIFORNIA PROPOSITION 65 MESSAGE

---

Some dust created by power sanding, sawing, grinding, drilling, and other construction activities contain chemicals known (to the State of California) to cause cancer, birth defects or other reproductive harm. Some examples of these chemicals are:

- Lead, from lead-based paints
- Crystalline silica from bricks, cement and other masonry products
- Arsenic and chromium, from chemically treated lumber

For further information, consult the following sources:

<http://www.osha.gov/dsg/topics/silicacrystalline/index.html>

<http://www.cdc.gov/niosh/docs/96-112/>

<http://oehha.ca.gov/prop65/law/P65law72003.html>

<http://www.dir.ca.gov/Title8/sub4.html>

Your risk from these exposures varies depending on how often you do this type of work. To reduce your exposure to these chemicals, work in a well-ventilated area, and work with approved safety equipment, such as dust masks that are specially designed to filter out microscopic particles. Where use of a dust extraction device is possible, it should be used. To achieve a high level of dust collection, use an industrial HEPA vacuum cleaner. Observe OSHA 29 CFR part 1926.57 and 1926.103.



### WARNING

Sawing and drilling generate dust. Excessive airborne particles may cause irritation to eyes, skin and respiratory tract. To avoid breathing impairment, always employ dust controls and protection suitable to the material being sawed or drilled; See OSHA (29 CFR Part 1910.1200).

**RULES FOR SAFE OPERATION****DANGER**

Failure to follow instructions in this manual may lead to serious injury or even death! This equipment is to be operated by trained and qualified personnel only! This equipment is for industrial use only.

The following safety guidelines should always be used when operating the Norton Clipper Self Propelled Flat Saw.

**MAINTENANCE SAFETY**

- **NEVER** lubricate components or attempt service on a running machine.
- Keep the machinery in proper running condition. Clean the machine after each day's use. Follow instructions for changing accessories. Inspect tool periodically and, if damaged, have repaired by authorized service facility.

**SET UP & TRANSPORTATION SAFETY**

- **ALWAYS** use caution and follow the instructions when lifting and transporting this machine.
- **ALWAYS** tie down the machine when transporting. **DO NOT** tow this machine behind a vehicle.
- **NEVER** transport with the blade mounted on the machine.
- Lift only from the lift bail.

**GENERAL SAFETY**

- **DO NOT** operate or service this equipment before reading this entire manual. Read and understand all warnings, instructions and controls on the machine.

This equipment should not be operated by persons under 18 years of age.



- **NEVER** operate this equipment without proper protective clothing, shatterproof glasses, steel-toed boots and other protective devices required by the job.

- **NEVER** operate this equipment when not feeling well due to fatigue, illness or taking medicine.
- **NEVER** operate this equipment under the influence of drugs or alcohol.
- Whenever necessary, replace nameplate, operation and safety decals when they become difficult to read.
- **ALWAYS** check the machine for loose bolts before starting.

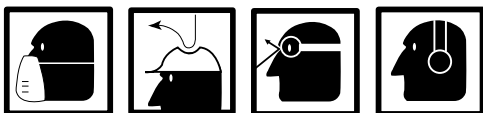

- **ALWAYS** wear proper respiratory, head, ear and eye protection equipment when operating this machine.

- **ALWAYS** store equipment properly when it is not being used. Equipment should be stored in a clean, dry location out of the reach of children.

- **CAUTION** must be observed while servicing the machine. Rotating parts can cause injury if contacted. Have all service performed by competent service personnel.
- Operate this machine only in well ventilated areas. **ALWAYS** ensure that the machine is on level ground before using.



- **NEVER** operate this machine in an explosive atmosphere.

- Establish a training program and give a copy of this manual to operators of this equipment. If you need extra copies, call (254) 918-2310.

### SAW BLADE SAFETY

---

For complete safety information, refer to ANSI Safety Code B7.1 available through the American National Standards Institute.



- **ALWAYS** keep area around the machine clear of obstructions and clear the work area of unnecessary people. Keep all body parts away from the blade and all other moving parts.



- Before starting the machine, check that all guards are in position and correctly fitted. **NEVER** allow blade exposure from the guard to be more than 180 degrees. **DO NOT** operate this machine with any guard removed.

- Inspect the blade, flanges and shafts for damage before installing the blade. **NEVER** use damaged or worn blade flanges.
- The blade shaft flanges must be of proper diameter for the size blade being used.
- Inspect the blade, flanges and size shown for each blade size. **DO NOT** exceed maximum blade speed shown, as excessive speed could result in blade breakage. Use **ONLY** blades marked with a maximum operating speed greater than the blade shaft speed. Verify speed and saw drive configuration by checking blade shaft RPM and pulley diameters and blade flange diameters.
- Use the correct blade for the type of work being done. Use only reinforced abrasive blades or steel center diamond blades and flanges supplied with the saw or manufactured for use on concrete saws. **DO NOT** use carbide-tipped blades. Check with the blade manufacturer if you do not know if blade is correct.
- Make sure the blade and flanges are clean and free of dirt and debris before mounting the blade on the saw. Verify the blade arbor hole matches the machine spindle before mounting the blade. **ALWAYS** mount the blade solidly and firmly. Wrench tighten the arbor nut.

**OPERATION & SAFETY DECALS**

The Norton Clipper Self Propelled Flat Saw is equipped with a number of safety decals (Figure 1) provided for operator safety and maintenance information. Should any of these decals become unreadable, replacements can be obtained by calling (254) 918-2310.

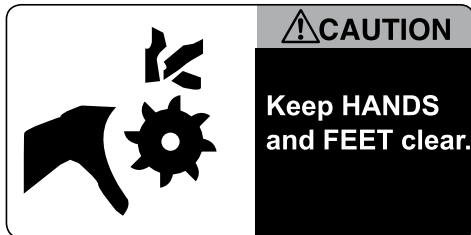

Decal A



Decal B



Decal C

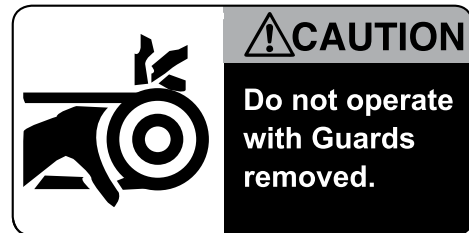

Decal D, E & G



Decal F

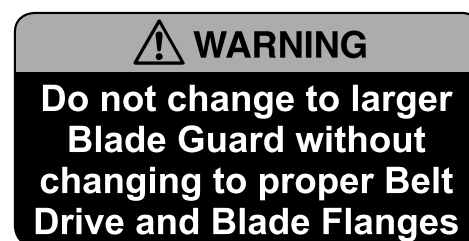

Decal H

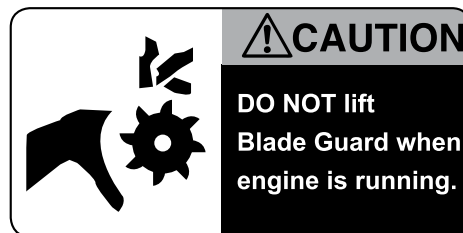

Decal J

Fig. 1 Norton Clipper Self Propelled saw safety decal sheet part# 246002



SAFETY DECAL LOCATIONS

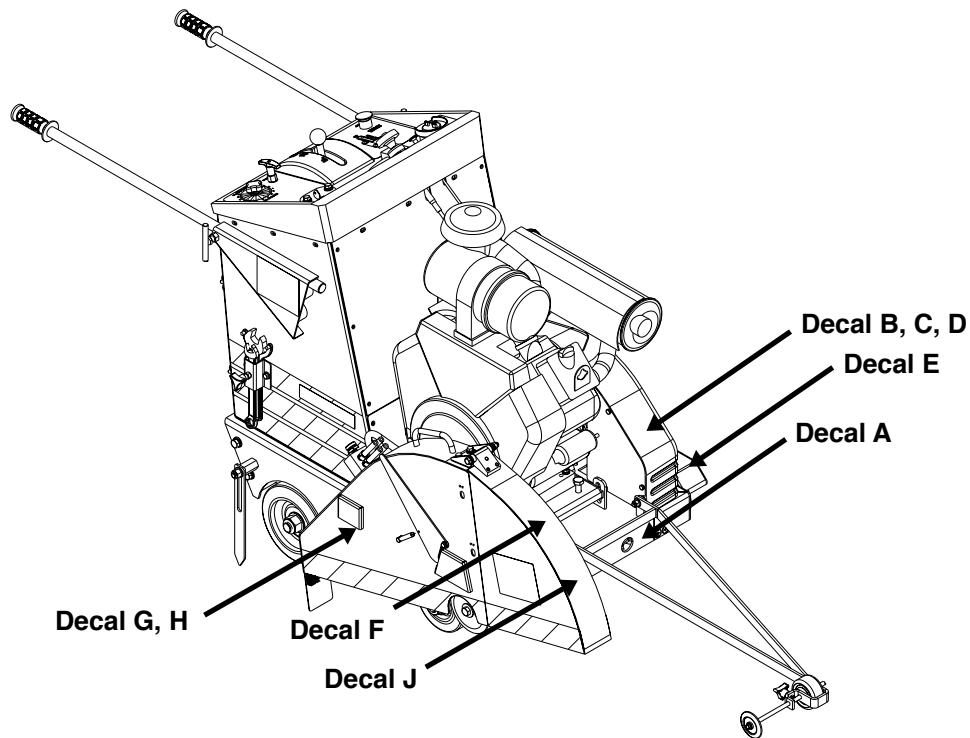
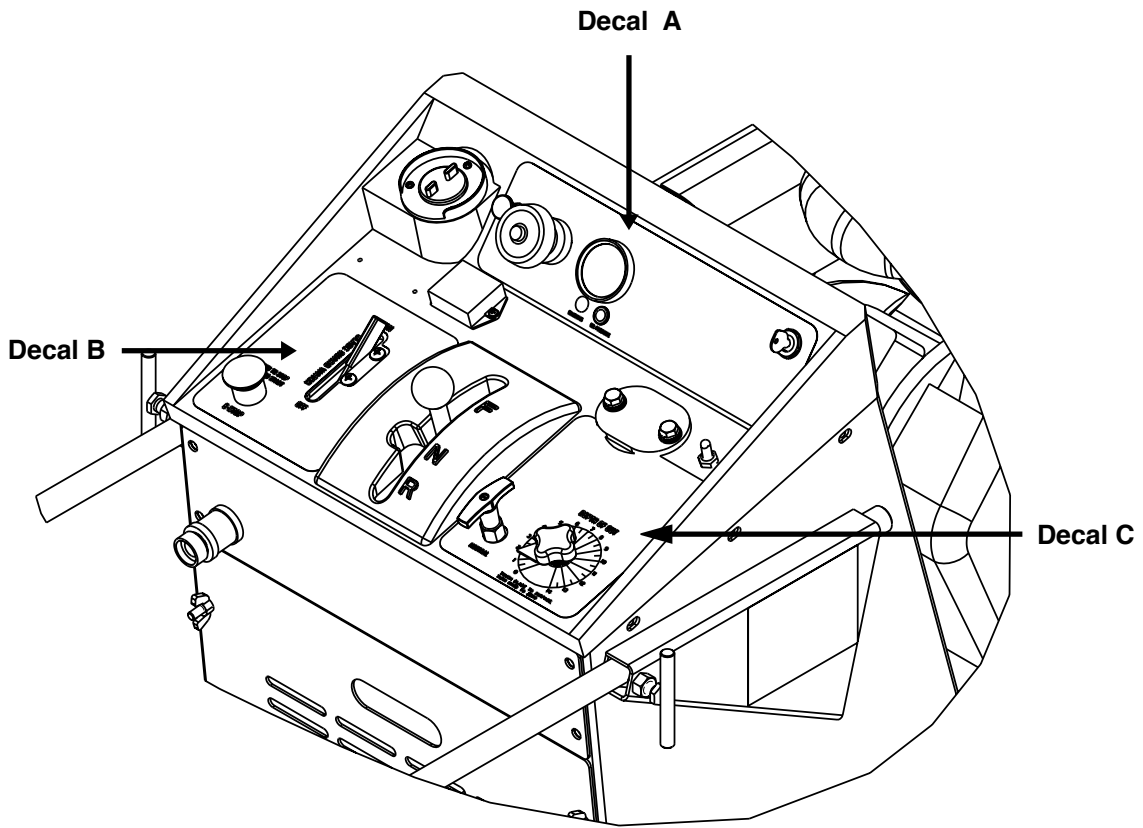

Fig. 2 Norton Clipper Self Propelled Flat Saw Safety Decal Locations

Decal	Location	Description
A	Machine Front	Caution Keep Hands and Feet Clear
B	Top of Belt Guard	Caution Do Not Overtension Belts
C	Top of Belt Guard	Caution Do Not Touch Hot Surface
D	Top of Belt Guard	Caution Do Not Operate with Guard Removed
E	Face of Shaft Guard	Caution Do Not Operate with Guard Removed
F	Top of Blade Guard	Blade Rotation Direction
G	Side of Blade Guard	Caution Do Not Operate with Guard Removed
H	Top of Blade Guard	Warning Do Not Change to Larger Blade Guard
J	Top of Blade Guard	Caution Do Not Lift Guard When Engine Running

**CONSOLE DECAL LOCATIONS**



**Fig. 3 Norton Clipper Self Propelled Flat Saw Console Decal Locations**

<b>Decal</b>	<b>Location</b>	<b>Description</b>
A	Console Top	Instrument Label
B	Console Left	Console Label Left
C	Console Right	Console Label Right

CONSOLE CONTROL DESCRIPTIONS

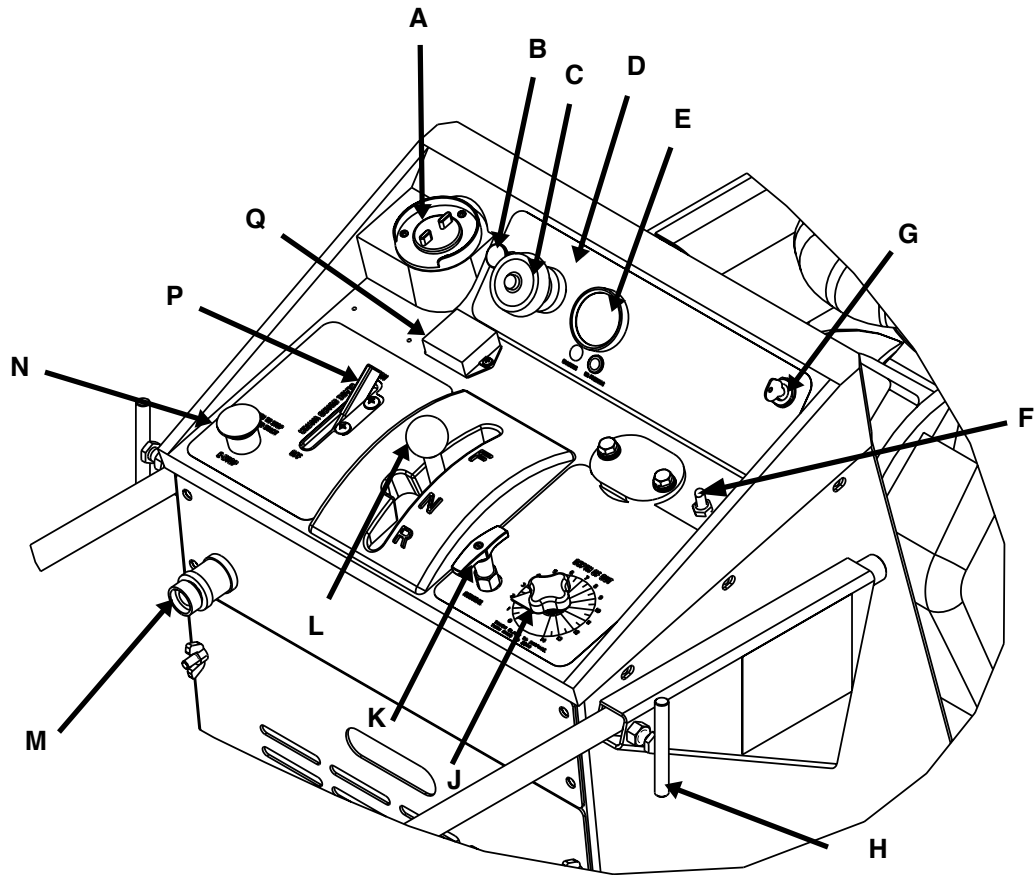

Fig. 4 Norton Clipper Self Propelled Flat Saw Console Control Descriptions

Object	Name	Function
A	Fuel Tank Fill	Fill the fuel tank at this location.
B	Choke	Use when cold starting.
C	Engine Throttle	Controls engine speed.
D	Oil Pressure Light	Indicates low oil pressure when illuminated.
E	Fuel Gauge	Shows the level of fuel in the fuel tank.
F	Raise/Lower Switch	Controls raising or lowering the blade out of or into the cut.
G	Keyed ON-OFF Start	Use to start engine.
H	T-Handle Knob	Use to tighten operator grip handles.
J	Depth Indicator	Displays cutting depth.
K	Engagement Handle	Engages Transmission.
L	FNR Lever	Used to Set Direction of Saw (Forward/Reverse/Neutral).
M	Water Inlet	Hook-up for standard water hose.
N	E-Stop	Stops down engine in an emergency!
P	Water Lever	Controls water flow to Blade Guard.
Q	Engine Tachometer/ Hour Meter	Shows the engine RPM's (running) and Engine Hours (stopped).

## SAW FEATURES

---

The Norton Clipper C35 Self Propelled Flat Saw has been engineered for operator convenience, improved accessibility for maintenance and better control during operations. The Norton Clipper C35 Self Propelled Flat Saw has been designed for both front and rear pivoting and has easily removable rear and side panels to provide easy accessibility for maintenance.

- Ergonomic FNR traverse control
- Quick release, auto latching bayonet mount blade guard
- 1-7/16 blade shaft with heavy duty pillow block bearings
- Three position adjustable solid steel handle bars
- Blade guard has garden hose style connector for quick disconnecting
- Rigid frame front pointer with high visibility guide wheel for accurate tracking
- Instrumentation includes engine tach, fuel level and hour meter
- Indicator lights for oil pressure and charging system
- Depth of cut indicator
- Valve control for delivery of water to blade guard
- Saw designed for left or right side mounting of blade and blade guard
- Blade guard water distribution system designed for optimal blade cooling
- Front pivot
- Removable rear and lower front panel for easy service
- 7 3VX V-belt drive from engine to center shaft
- Hand wheel for positive adjustment of cutting depth
- Wide front wheel base increases stability and allows ramp loading/unloading
- Eaton model 6 Hydrostatic transmission coupled to an Norton trans-axle
- Transmission can be disengaged from axle to allow saw to be pushed manually
- Travel speed 0-220 FPM forward, 0-100 FPM reverse
- Neutral start switch to prevent starting with transmission in gear
- Made in the U.S.A.

<b>TECHNICAL SPECIFICATIONS</b>	<b>C3520SS</b>	<b>C3526SS</b>	<b>C3530SS</b>
Product Number	701846 <b>42465</b> 3	701846 <b>42466</b> 0	701846 <b>42467</b> 7
Blade Guard Capacity – in (mm)	20" (508)	26" (660)	30" (762)
Maximum Depth of Cut – in (mm)	7" (178)	9-1/2" (241)	12-1/2" (318)
Arbor Size – in (mm)	1" (25.4)	1" (25.4)	1" (25.4)
Blade Flange Diameter – in (mm)	4" (102)	5" (127)	5" (127)
Blade Shaft RPM	1,900	1,900	1,900
Blade Shaft Diameter – in (mm)	1-7/16" (37)		
Blade Shaft Bearings	Pillow Block		
Blade Shaft Drive	7 Belts		
Blade Guard Attachment	Quick Detach Bayonet		
Blade Control	Electric		
Axle – Front – in (mm)	1" (25.4)		
Axle – Rear – in (mm)	1" (25.4)		
Wheels – Front D x W x B – in (mm)	6"x2-1/2"x1" (152x64x25)		
Wheels – Rear D x W x B – in (mm)	8"x2-1/2"x1" (203x64x25)		
Handle Bars/Adjustment Length – in (mm)	32-1/2" (826)		
Transmission	Eaton Hydrostatic		
Rear End/Differential	Enclosed Gears		
Control	Forward/Reverse Control, Engage/Disengaged Controls		
Speed	0-220 FPM (Forward) 0-100 FPM (Reverse)		
Chassis	Heavy Duty jig-welded box frame		
Power Source	Gasoline, 2 Cylinders 4 Cycle		
Engine Type	Briggs Vanguard		
Specifications	61347701710		
Maximum Horsepower*	35 HP (26kw)		
Displacement – cu In (l)	60.6 cu in (0.993 l)		
Bore – in (mm)	3.366" (85.5)		
Stroke – in (mm)	3.406" (86.5)		
Cylinders/Cycle	2 Cylinders 4 Cycle		
Fuel Capacity – gal (l)	5 gal (18.9 l)		
Oil Capacity – qt (l)	2.5 qt. (2.4 l)		
Air Filter	Three Stage		
Starter	Electric		
Engine Cooling	Air		

**SAW DIMENSIONS**

Height – in (mm)	42" (1,069)	42" (1,069)	42" (1,069)
Minimum Saw Length (Transport) – in (mm)	49-1/2" (1,257)	49-1/2" (1,257)	49-1/2" (1,257)
Maximum Saw Length (Working) – in (mm)	109-3/4" (2,788)	109-3/4" (2,788)	109-3/4" (2,788)
Maximum Pointer Length – in (mm)	33-3/4" (857)	33-3/4" (857)	33-3/4" (857)
Frame Width – in (mm)	22-1/2" (572)	22-1/2" (572)	22-1/2" (572)
Saw Width – in (mm)	29" (737)	29" (737)	29" (737)
Front (Outside to Outside Wheel Width) – in (mm)	19" (483)	19" (483)	19" (483)
Rear (Outside to Outside Wheel Width) – in (mm)	22-3/4" (578)	22-3/4" (578)	22-3/4" (578)
Blade to Wall – in (mm)	1-13/16" (46)	1-13/16" (46)	1-13/16" (46)
Wheel Base Length – in (mm)	20-1/4" (514)	20-1/4" (514)	20-1/4" (514)
Blade Shaft Maximum Height – in (mm)	17-1/8" (435)	17-1/8" (435)	17-1/8" (435)
Weight Crated – lbs (kg)	750 lbs (341 kg)	750 lbs (341 kg)	750 lbs (341 kg)
Weight Uncrated – lbs (kg)	650 lbs (295 kg)	650 lbs (295 kg)	650 lbs (295 kg)

\*= DATA PROVIDED BY MOTOR/ENGINE MANUFACTURER

**PRE-OPERATION CHECKLIST**

---

**WARNING**

Before leaving our factory, every machine is thoroughly tested. Follow instructions strictly and your machine will give you long service in normal operating conditions.



Before starting up the machine, make sure you read this entire Operation Manual and are familiar with the operation of the machine.

**Machine Cold**

---

1. Check engine oil. See Engine Owner's Manual for type & quantity.
2. Connect battery cables.
3. Check hydrostatic transmission fluid level.
4. Check the engine air cleaner.

**SCHEDULE MAINTENANCE QUICK REFERENCE**

---

**1-2 Hour Operation Checklist**

---

**WARNING**

**ALWAYS** locate machine on a level surface with the engine "OFF" and the ignition switch set in the "OFF" position before performing any maintenance. Let the machine cool down prior to any service. Ensure the parking brake is set.

1. Check the engine air cleaner hose clamps. Tighten as required.
2. Tension the blade drive V-belts. **DO NOT** overtension.

**WARNING**

Before performing any maintenance, **ALWAYS** locate machine on a level surface with the engine "OFF" and the ignition switch set in the "OFF" position.

**Service Daily**

---

1. Check engine oil level.
2. Check blade guard for damage.
3. Check hoses and clamps for damage or looseness. Tighten or replace as necessary.
4. Check air cleaner for restriction. Replace at regular intervals air filters.

**Other time interval service**

---

See the Maintenance Schedule Table on Page 23.

**NOTICE**

Before mounting the blade, machine should be turned “OFF”. Clean the blade collars and stub shaft.

**BLADE MOUNTING INSTRUCTIONS**

1. Remove Blade Guard.
  - A. Unscrew the hose fitting to disconnect hose (Figure 5).
  - B. Hold the Blade Guard by the handle (Figure 6). Release the inner latch.
  - C. Pull the guard up and off the Saw.



**Fig. 5 Unscrew Hose Fitting**



**Fig. 6 Hold Blade Guard**

2. Remove arbor bolt. If blade is mounted on right side saw, the bolt has left hand threads. To remove turn clockwise. If the blade is mounted on left side of saw, nut has right hand threads. To remove, turn counter-clockwise (Figure 7).
3. Pull out outer flange (Figure 8).

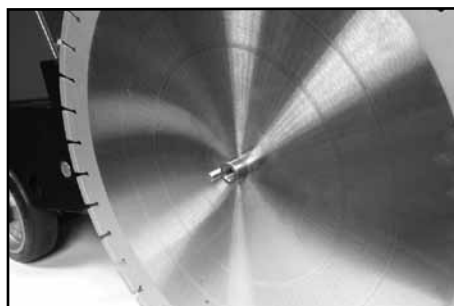

**Fig. 7 Remove Arbor Bolt**

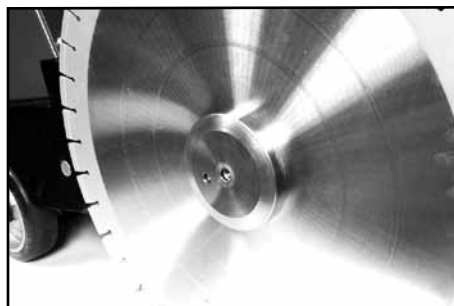

**Fig. 8 Pull Out Outer Flange**

4. Install new blade (Figure 9).  
Slide in the outer flange in place (Figure 10).



**Fig. 9 Install New Blade**



**Fig. 10 Slide Outer Flange in place**

**BLADE MOUNTING INSTRUCTIONS CONTINUED**

6. Tighten the arbor bolt (Figure 11).
7. Install the blade guard in place. Make sure that the guard locks in place and connect the hose (Figure 12).

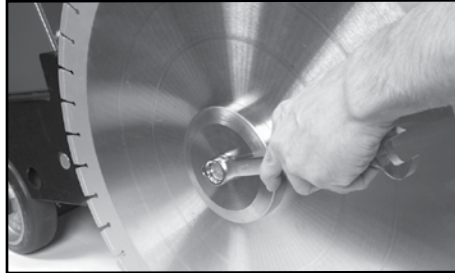
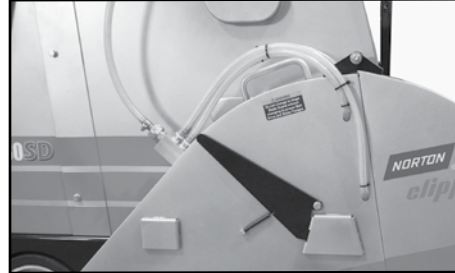
**Fig. 11 Tighten Arbor Bolt****Fig. 12 Install Blade Guard****WARNING**

Observe the rotation arrow on blade and **DO NOT** exceed maximum RPM stamped on the blade. To set proper RPM, consult the Blade Guards and Blade Sizes Table on page 14.

**NOTICE**

To meet ANSI safety standards, larger diameter blade collars are required for large diameter blades. Information is available upon request.

**NOTICE**

We recommend the use of Norton diamond blades with these saws.



**STARTING ENGINE**

---

**NOTICE**

Read the engine instructions manual before starting.

**WARNING**

Be sure blade is unobstructed and not resting on ground.

**WARNING**

Be sure hands and feet are clear of blade.

1. Check engine oil. Add oil if low.
2. Check fuel level. Add fuel if low.
3. Check cooling air intake areas and external surfaces of engine. Make sure surfaces are clean and unobstructed.
4. Check that air cleaner components and all shrouds, equipment covers and guards are in place and securely fastened.

**STARTING INSTRUCTIONS**

---

1. Verify that E-Stop is pulled out.
2. Place Drive Control Level in **NEUTRAL**.
3. Verify the transmission is in **NEUTRAL**.
4. Pull throttle handle out half-way and turn to lock in place.
5. Close choke by pulling choke button to full out position.
6. Start engine by rotating starter switch to the right.

**NOTICE**

**DO NOT** crank engine for more than 30 seconds at a time. If engine fails to start, wait about 2 minutes between cranking periods to prevent starter from overheating.

8. After engine starts, push choke button in as required for smooth running.

**NOTICE**

Allow engine to warm up at least 3 minutes before applying load.

9. When engine is warm, pull throttle out to maximum.
10. To stop engine, push throttle to idle, rotate ignition switch to “OFF” position.

**NOTICE**

If the engine has been running hard and is hot, do not shut engine off abruptly. Cool engine by removing load and allowing engine to run idle for 3 to 5 minutes.

**SAW GUIDE ALIGNMENT AND ADJUSTMENT****⚠ WARNING**

This operation is performed with the engine "OFF"!

The front and rear pointers are set in line at the factory. However, the pointers should be checked for proper alignment with the blade after every use. The following are the procedures for aligning the pointers with the blade, with the engine shut off.

1. Using a straight edge, carefully mark a line 12 feet long on a smooth level concrete surface.
2. Place the saw parallel to the line. Lower the blade and center it over the line.
3. **FRONT:** With the blade centered over the line and the saw frame parallel to the line, lower the front pointer assembly and position the pointer over the line.
4. **REAR:** With the blade centered over the line and the saw frame parallel to the line, loose the pointer and adjust up or down and ensure that it touches the line.
5. Finally, roll the saw along the entire length of the line. The saw should lead off no more than 6 inches to the left in 12 feet of forward travel. Adjust the pointer in or out if the lead-off is outside this parameter.
6. Secure hardware.

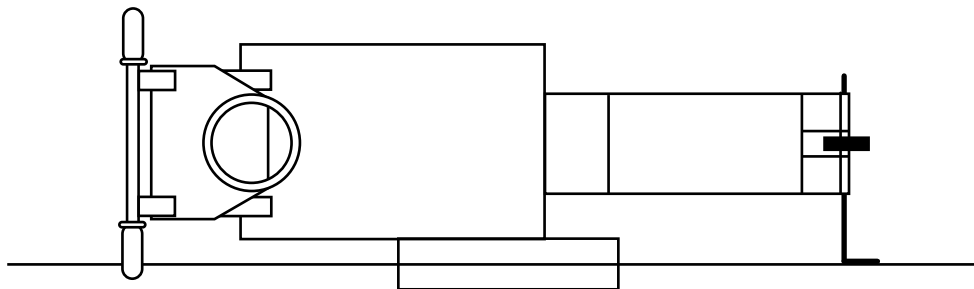

**Fig. 13 Pointer Alignment**

## MANEUVERING THE SAW

---



### WARNING

The blade is spinning whenever the saw is running. Raise the blade as high as possible when maneuvering so that the blade will not strike the pavement.

## DRY CUTTING

---

Dry cutting blades have been specially designed for use with concrete saws. Ensure that the blade you are using is clearly marked for dry cutting.

When dry cutting, it is important to keep the air filter clean. Check the condition of the filter at least every four (4) hours of operation. Clean the pre-filter (wash in soapy water and re-oil) and change the paper filters as soon as it becomes clogged. Concrete dust is very abrasive and will quickly damage internal engine parts, causing loss of compression and eventual engine failure.

Saw only as deep as the specifications and job conditions require. Remember airflow helps to cool the blade during dry cutting. Cutting too deep with one pass, or exerting excessive forward or side pressure can be dangerous. Step cut in increments of 1 inch (25 mm) or less, for the best results.

If reinforced abrasive blades are used for cured concrete, it is usually better to saw only 1 inch deep per pass. If deeper cuts are required, cut in multiple passes.

Thinner Diamond Blades are especially advantageous when cutting dry.

## WET CUTTING

---

The water used on the blade is to provide coolant during cutting and to flush the concrete cutting from the cut. Turn the water control to full "on" when using wet cutting blades. The required flow rate is 5 to 8 gallons per minute.

## SPEED CONTROL-LEVER USE AND ADJUSTMENT

---

Move the saw forward by pushing the lever away from the operator and move the saw in reverse by pulling the lever toward the operator. The further you push this lever, the faster the saw travels.



### WARNING

Before starting the engine, place this lever in **NEUTRAL**.

## ENGAGING THE DRIVE UNIT

This saw is driven by a hydrostatic transmission. To engage the transmission, **PULL** the Engagement Handle up and turn to either direction to lock (Figure 14). To disengage the transmission, twist the Engagement Handle and **PUSH** down.



### NOTICE

**DO NOT** engage the transmission unless FNR Lever (Figure 14) is in **NEUTRAL**.



Fig. 14 Pull Engagement Handle

## WATER HOOK UP

Prior to starting the engine, you should hook up the water hose to the Water Inlet (Figure 15) and visually inspect it to make sure that water is flowing to the blade. Hook up the hose to the the unit and turn on the water source. Open the water valve. Next, lift the front of the blade guard and visually inspect the make sure water is flowing out of each of the tubes. If either of the holes is blocked, flush impurities from the tube.



### NOTICE

Water flow volume can be metered by opening the Water Valve Lever partially (Figure 16).

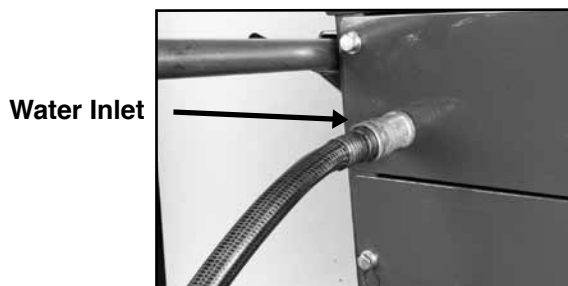

Fig. 15 Attach Hose to Water Inlet

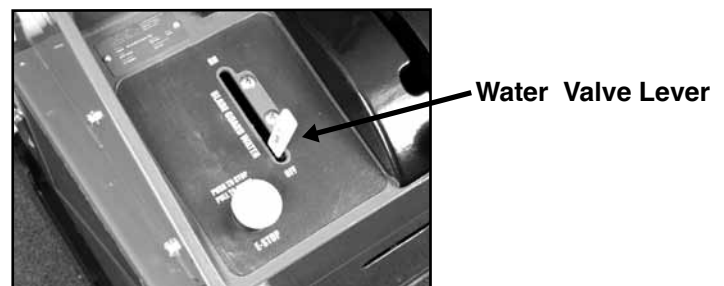

Fig. 16 Partially open Water Valve

## DEPTH INDICATOR

The saw is equipped with a Depth Indicator. The Depth Indicator (Figure 17) tells you approximately how deep you are in the cut. To set the indicator, you need to first lower the blade until it is just touching the ground and then rotate the knob to 0.

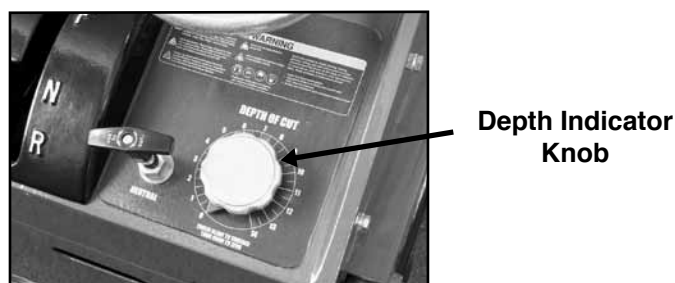

Fig. 17 Depth Indicator Knob

## ENGINE

The operation and life of the engine depends on proper maintenance. Do not start engine until engine pre-check is complete. The engine pre-check consists of checking the oil, fuel level, air filter and greasing the wheel, axle, drive unit and arbor bearings. Basic engine maintenance is shown in Maintenance Schedule Table on the next page. For more detailed information, please refer to the Engine Operator Maintenance Manual and Warranty provided with the saw.

### NOTICE

When breaking-in a new saw, we recommend running the engine for one hour with no load prior to actual use on the job.

## AIR CLEANER

Due to the dusty conditions created by sawing, it is essential to check the engine air cleaner element daily. Remove the element and shake out the accumulated dust and dirt. Wipe out dirt from the inside cover and from the housing. Check the engine manual for washing instructions. Stocking replacement filters is strongly recommended.

## ARBOR, AXLE, DRIVE UNIT AND WHEEL BEARINGS

Blades shaft, Axle, Drive Unit, and Wheel Bearings should be greased according to the Maintenance Schedule table on the next page.

### WARNING

**DO NOT** inspect when the engine is running.

Use of high quality detergent oil of API (American Petroleum Institute) service class SF or SG. Select the viscosity based on the air temperature at the time of operation. For temperatures below 0°F, 5W-20 or 5W-30 oil is recommended. For temperatures above 0°, 10W-30 or 10W-40 oil is recommended. Check your engine manual for other recommendations.

## HYDROSTATIC DRIVE UNIT

The fluid shipped in your hydrostatic transmission is a fluid having a viscosity equivalent to SAE 20W20. Mobil fluid 300 or any other oil equivalent to SAE 20W20 is preferred by Eaton Transmission. The expansion tank is marked for proper fluid level. It should be checked when unit is cold. **DO NOT** allow the unit to run low on oil. If the unit is low, you can add oil by removing the cap (Figure 18).

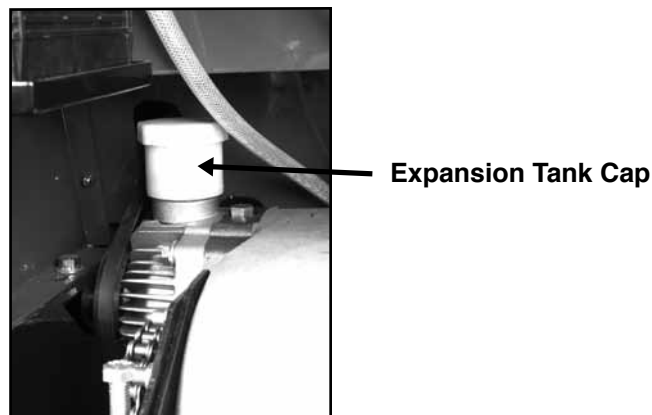

Fig. 18 Expansion Tank Cap

**MAINTENANCE SCHEDULE**

MAINTENANCE SCHEDULE	DAILY	25 HOURS	50 HOURS	250 HOURS
Check Oil Level	X			
Check Air Filter	X			
Check Air Intake, Clean if Necessary	X			
Grease Front Wheel Bearings		X		
Grease Rear Wheel Pillow Blocks		X		
Grease Front Axle Journal Bearings		X		
Check Transmission Fluid, Add if Low		X		
Check Power Unit Fluid, Add if Low		X		
Change Oil		X		
Check Blade Shaft Oil, Add if Low			X	
Service Air Cleaner Element			X	
Change Oil Filter			X	
Inspect Fuel Filter, Replace if Dirty				X
Inspect Spark Plugs and Ignition System				X
Inspect Cooling System and Clean				X
Inspect Starting Motor				X

\* See Engine Manual for specific engine maintenance information and schedule.

**TROUBLESHOOTING**

When trouble occurs, be sure to check the simple causes which, at first, may seem too obvious to be considered. Refer to the table below for problems and their possible causes.

<b>TRANSMISSION</b>	<b>Cause</b>	<b>Loose Transmission Linkage</b>	<b>Oil Level</b>	<b>Cooling Fan</b>	<b>Water in Oil Reservoir</b>	<b>Dirty Cooling Fans</b>	<b>Loose Drive Chain</b>
	<b>Problem</b>						
	Transmission jerky when starting	X	X				X
	Transmission operates in one direction	X					
	Transmission operating hot	X	X	X		X	
	Oil color is black			X		X	
	Oil color is milky				X		

<b>ENGINE</b>	<b>Cause</b>	<b>No Fuel</b>	<b>Improper Fuel</b>	<b>Dirt in Fuel Line</b>	<b>Fuse Burned Out</b>	<b>Incorrect Oil Level</b>	<b>Dirty Air Filter</b>	<b>Faulty Spark Plugs</b>
	<b>Problem</b>							
	Will not start	X		X	X		X	X
	Hard starting	X	X	X			X	X
	Stops suddenly	X		X		X	X	
	Lacks power		X	X		X	X	X
	Operates erratically		X	X			X	X
	Knocks or pings		X					X
	Skips or misfires			X			X	X
	Back fires			X			X	X
	Overheats			X			X	X
	High Fuel Consumption						X	X

<b>OTHER</b>	<b>Cause</b>	<b>Improper Blade for the Application</b>	<b>Improper Belt Tension</b>	<b>Damage Caused by External Objects</b>
	<b>Problem</b>			
	Reduced blade life	X	X	
	Excessive belt wear		X	X

**STEP CUTTING**

---

1. Follow general instructions outlined in the section Operating the Saw pages 18 to 19.
2. When deep sawing (more than 4") or concrete with hard aggregate, sawing to full depth in several cuts should be made in incremental steps of 1-1/2 to 2 inches until the desired depth of cut is reached. In softer aggregates or asphalt, it may be possible to saw full depth in two passes.
3. Gradually move the speed control lever forward to increase the cutting speed. If the blade stalls in the cut (which can happen when deep sawing) immediately raise blade from cut. If not done at once, the belts will spin freely and burn. Check belts for proper tension and continue sawing at a slower rate of speed.
4. On final pass, lower the blade until it hits the sub-base (sandy color will appear in the water being discharged from the cut). Raise blade approximately 1/2" from bottom. The sand and gravel particles of the sub-base may cause premature wear or damage to the saw blade.
5. It is common, on the final pass of the cut, for pavement to wedge blade, particularly on a hot day. When this happens, immediately stop engine. If the blade is wedged, remove the Blade Shaft Bolt and Outside Collar and move the saw away from the blade. To remove a wedged blade from the concrete, use a jack hammer and carefully chip out concrete around the blade. (Pounding or twisting the blade may cause severe damage).
6. Go slowly with a new blade until it "opens up" that is, until you can see and feel the diamonds.
7. Small corrections can be made by leaning on handles.  
Deep sawing is very hard on saws and blades. Experienced operators soon get a "feel" for the saw and are constantly on guard to slow down when they hit excessive steel or hard aggregate.



**CONTACT**

---

Please contact Saint-Gobain Abrasives, Inc. Customer Service Department with any questions you might have regarding distributors, parts or service.

Telephone: **(254) 918-2310**

Fax: **(254) 918-2312**

Customer Service Hours: **Monday through Friday, 6AM-6PM CST**

**Saint-Gobain Abrasives, Inc.  
2770 W. Washington St.  
Stephenville, TX 76401**

**WARRANTY**

---

Norton warrants all products manufactured by it against defects in workmanship or materials for a period of one (1) year from the date of shipment to the customer.

The responsibility of Norton under this warranty is limited to replacement or repair of defective parts at Norton's Indianapolis, Indiana Distribution Center, or at a point designated by it, of such part as shall appear to us upon inspection at such point, to have been defective in material or workmanship, with expense for transportation borne by the customer.

In no event shall Norton be liable for consequential or incidental damages arising out of the failure of any product to operate properly.

Integral units such as **gasoline engines, electric motors, batteries, tires, transmissions, etc.**, are excluded from this warranty and are subject to the prime manufacturer's warranty.

This warranty is in lieu of all other warranties, expressed or implied, and all such other warranties are hereby disclaimed.





**NORTON**

**clipper**

# WARNING

Some dust created by power sanding, sawing, grinding, drilling, and other construction activities contains chemicals known to cause cancer, birth defects or other reproductive harm. Some examples of these chemicals are:

- Lead from lead based paints,
- Crystalline silica from bricks and cement and other masonry products, and
- Arsenic and chromium from chemically-treated lumber.

Your risk from these exposures varies, depending on how often you do this type of work. To reduce your exposure to these chemicals: work in a well ventilated area, and work with approved safety equipment, such as those dust masks that are specially designed to filter out microscopic particles.

**Saint-Gobain Abrasives, Inc.**  
2770 West Washington Street  
Stephenville, TX 76401-3798

Phone: 254-918-2310  
Fax: 254-918-2312

**ALL THE MUSCLE YOU NEED™.**

**NORTON**

SAINT-GOBAIN